

FRONT

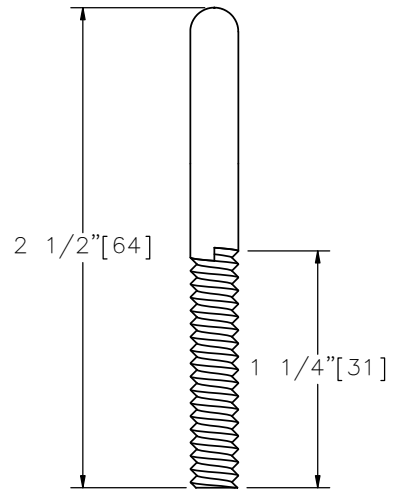

SIDE

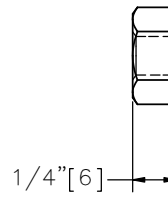
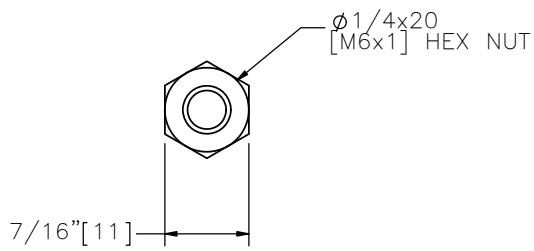

U-BOLT AND NUT



FBU01

SHEET NO.

DATE:

1 of 2

4/16/2013

SPECIFICATIONS

The U-Bolt shall be galvanized ASTM A307 steel.

The nut shall be galvanized or zinc-coated ASTM A563D steel.

Zinc-coated bolts and nuts shall be treated according to either AASHTO M232 (ASTM A153) or AASHTO M298 (ASTM B695) for Class 50.

Dimensional tolerances not shown or implied are intended to be those consistent with the proper functioning of the part, including its appearance and accepted manufacturing processes.

INTENDED USE

The U-Bolt and Nut are used in the thrie-beam bullnose end terminals, SET03a-b.

CONTACT INFORMATION

Midwest Roadside Safety Facility
Nebraska Transportation Center
University of Nebraska-Lincoln
130 Whittier Research Center
2200 Vine Street
Lincoln, NE 68583-0853
(402) 472-0965
Email: mwrfsf@unl.edu
Website: <http://mwrfsf.unl.edu>

U-BOLT AND NUT

FBU01

SHEET NO.

DATE:

2 of 2

4/16/2013

