



U.S. Department
of Transportation

**Federal Highway
Administration**

1200 New Jersey Ave., SE
Washington, D.C. 20590

December 27, 2016

In Reply Refer To:
HSST-1/B-269

Mr. Scott Rosenbaugh
Midwest Roadside Safety Facility
130 Whittier Research Center
2200 Vine Street
Lincoln, NE 68583-0853

Dear Mr. Rosenbaugh:

This letter is in response to your September 29 2016 request for the Federal Highway Administration (FHWA) to review a roadside safety device, hardware, or system for eligibility for reimbursement under the Federal-aid highway program. This FHWA letter of eligibility is assigned FHWA control number B-268 and is valid until a subsequent letter is issued by FHWA that expressly references this device.

Decision

The following devices are eligible, with details provided in the form which is attached as an integral part of this letter:

- Manitoba Constrained-Width, Tall Wall median barrier

Scope of this Letter

To be found eligible for Federal-aid funding, new roadside safety devices should meet the crash test and evaluation criteria contained in the American Association of State Highway and Transportation Officials' Manual for Assessing Safety Hardware (MASH). However, the FHWA, the Department of Transportation, and the United States Government do not regulate the manufacture of roadside safety devices. Eligibility for reimbursement under the Federal-aid highway program does not establish approval, certification or endorsement of the device for any particular purpose or use.

This letter is not a determination by the FHWA, the Department of Transportation, or the United States Government that a vehicle crash involving the device will result in any particular outcome, nor is it a guarantee of the in-service performance of this device. Proper manufacturing, installation, and maintenance are required in order for this device to function as tested.

This finding of eligibility is limited to the crashworthiness of the system and does not cover other structural features, nor conformity with the Manual on Uniform Traffic Control Devices.

This finding of eligibility is limited to the crashworthiness of the system and does not cover other structural features, nor conformity with the Manual on Uniform Traffic Control Devices.

Eligibility for Reimbursement

Based solely on a review of crash test results and certifications submitted by the manufacturer, and the crash test laboratory, FHWA agrees that the device described herein meets the crash test and evaluation criteria of the American Association of State Highway and Transportation Officials' Manual for Assessing Safety Hardware (MASH). Therefore, the device is eligible for reimbursement under the Federal-aid highway program if installed under the range of tested conditions.

Name of system: Manitoba Constrained-Width, Tall Wall Median Barrier

Type of system: Longitudinal Barrier

Test Level: MASH Test Level 5 (TL5)

Testing conducted by: Midwest Roadside Safety Facility

Date of request: September 29, 2016

Date initially acknowledged: October 4, 2016

Date of completed package: September 29, 2016

FHWA concurs with the recommendation of the accredited crash testing laboratory as stated within the attached form. In addition, the proposed barrier meets conditions as per AASHTO Roadside Design Guide, Section 7.4.2.

Full Description of the Eligible Device

The device and supporting documentation, including reports of the crash tests or other testing done, videos of any crash testing, and/or drawings of the device, are described in the attached form.

Notice

If a manufacturer makes any modification to any of their roadside safety hardware that has an existing eligibility letter from FHWA, the manufacturer must notify FHWA of such modification with a request for continued eligibility for reimbursement. The notice of all modifications to a device must be accompanied by:

- Significant modifications – For these modifications, crash test results must be submitted with accompanying documentation and videos.
- Non-signification modifications – For these modifications, a statement from the crash test laboratory on the potential effect of the modification on the ability of the device to meet the relevant crash test criteria.

FHWA's determination of continued eligibility for the modified hardware will be based on whether the modified hardware will continue to meet the relevant crash test criteria.

Any user or agency relying on this eligibility letter is expected to use the same designs, specifications, drawings, installation and maintenance instructions as those submitted for review.

You are expected to certify to potential users that the hardware furnished has the same chemistry, mechanical properties, and geometry as that submitted for review, and that it will meet the test and evaluation criteria of the MASH.

Issuance of this letter does not convey property rights of any sort or any exclusive privilege. This letter is based on the premise that information and reports submitted by you are accurate and correct. We reserve the right to modify or revoke this letter if: (1) there are any inaccuracies in the information submitted in support of your request for this letter, (2) the qualification testing was flawed, (3) in-service performance or other information reveals safety problems, (4) the system is significantly different from the version that was crash tested, or (5) any other information indicates that the letter was issued in error or otherwise does not reflect full and complete information about the crashworthiness of the system.

Standard Provisions

- To prevent misunderstanding by others, this letter of eligibility designated as FHWA control number B-269 shall not be reproduced except in full. This letter and the test documentation upon which it is based are public information. All such letters and documentation may be reviewed upon request.
- This letter shall not be construed as authorization or consent by the FHWA to use, manufacture, or sell any patented system for which the applicant is not the patent holder.
- If the subject device is a patented product it may be considered to be proprietary. If proprietary systems are specified by a highway agency for use on Federal-aid projects: (a) they must be supplied through competitive bidding with equally suitable unpatented items; (b) the highway agency must certify that they are essential for synchronization with the existing highway facilities or that no equally suitable alternative exists; or (c) they must be used for research or for a distinctive type of construction on relatively short sections of road for experimental purposes. Our regulations concerning proprietary products are contained in Title 23, Code of Federal Regulations, Section 635.411.

Sincerely yours,



Michael S. Griffith
Director, Office of Safety Technologies
Office of Safety

Enclosures

Request for Federal Aid Reimbursement Eligibility of Highway Safety Hardware

Submitter	Date of Request:	September 29, 2016	<input checked="" type="radio"/> New <input type="radio"/> Resubmission
	Name:	Scott Rosenbaugh	
	Company:	Midwest Roadside Safety Facility	
	Address:	130 Whittier Research Center, 2200 Vine Street, Lincoln, NE 68583-0853	
	Country:	USA	
	To:	Michael S. Griffith, Director FHWA, Office of Safety Technologies	

I request the following devices be considered eligible for reimbursement under the Federal-aid highway program.

Device & Testing Criterion - Enter from right to left starting with Test Level

!-!-!

System Type	Submission Type	Device Name / Variant	Testing Criterion	Test Level
'B': Rigid/Semi-Rigid Barriers (Roadside, Median, Bridge Railings)	<input type="radio"/> Physical Crash Testing <input checked="" type="radio"/> Engineering Analysis	Manitoba Constrained-Width, Tall Wall median barrier	AASHTO MASH	TL5

By submitting this request for review and evaluation by the Federal Highway Administration, I certify that the product(s) was (were) tested in conformity with the AASHTO Manual for Assessing Safety Hardware and that the evaluation results meet the appropriate evaluation criteria in the MASH.

Individual or Organization responsible for the product:

Contact Name:	Scott Rosenbaugh	Same as Submitter <input checked="" type="checkbox"/>
Company Name:	Midwest Roadside Safety Facility	Same as Submitter <input checked="" type="checkbox"/>
Address:	130 Whittier Research Center, 2200 Vine Street, Lincoln, NE 68583-0853	Same as Submitter <input checked="" type="checkbox"/>
Country:	USA	Same as Submitter <input checked="" type="checkbox"/>

Enter below all disclosures of financial interests as required by the FHWA 'Federal-Aid Reimbursement Eligibility Process for Safety Hardware Devices' document.

The Midwest Roadside Safety Facility (MwRSF) and its employees are requesting a letter of eligibility on behalf of Manitoba Infrastructure .

MwRSF's financial interests are as follows:

- (i) No compensation, including wages, salaries, commissions, professional fees, or fees for business referrals;
- (ii) Consulting relationships consist of answering design and implementation questions;
- (iii) Research funding and support will cease on September 30, 2016. Currently, MwRSF has no additional or future research projects funded by Manitoba Infrastructure.
- (iv) No patents, copyrights, or other intellectual property interests for this system;
- (v) No licenses or contractual relationships for this system; and
- (vi) No business ownership and investment interests for this system.

PRODUCT DESCRIPTION

<input checked="" type="radio"/> New Hardware or Significant Modification	<input type="radio"/> Modification to Existing Hardware	
The Manitoba Constrained-Width, Tall Wall median barrier is a reinforced concrete barrier with a constant front/back slope measuring 9 degrees from vertical. The barrier is 1,250 mm tall, is 200 mm wide at the top, and is 6000 mm wide at the base. Steel reinforcement consists of Canadian Metric Rebar. Longitudinal steel is comprised of ten M10 bars, while the transverse steel is comprised of M20 U-bar stirrups spaced at 400 mm and 300 mm for interior and end sections, respectively.		
<h3>CRASH TESTING</h3>		
By signature below, the Engineer affiliated with the testing laboratory, agrees in support of this submission that all of the critical and relevant crash tests for this device listed above were conducted to meet the MASH test criteria. The Engineer has determined that no other crash tests are necessary to determine the device meets the MASH criteria.		
Engineer Name:	Scott Rosenbaugh	
Engineer Signature:	<div style="display: flex; align-items: center;"> <div style="flex: 1;"> <h2 style="margin: 0;">Scott Rosenbaugh</h2> </div> <div style="font-size: 0.8em; margin-left: 10px;"> Digitally signed by Scott Rosenbaugh DN: cn=Scott Rosenbaugh, o=MWRSF, ou, email=srosenbaugh2@unl.edu, c=US Date: 2016.09.29 13:55:42 -05'00' </div> </div>	
Address:	130 Whittier Research Center, 2200 Vine Street, Lincoln, NE 68583-0853	Same as Submitter <input checked="" type="checkbox"/>
Country:	USA	Same as Submitter <input checked="" type="checkbox"/>

A brief description of each crash test and its result:

Required Test Number	Narrative Description	Evaluation Results
5-10 (1100C)	<p>Same barrier shape as the Manitoba Constrained-Width, Tall Wall bridge rail.</p> <p>Single slope concrete barriers have not been evaluated with the 1100C MASH small car, but they have been evaluated with the 820C small car under NCHRP Report 350. The California Single-Slope barrier was successfully tested to NCHRP Report 350 at heights of 56" and 32", as documented in:</p> <p>1) Jewell, J.R., Vehicle crash tests of a slip-formed, single slope, concrete median barrier with integral concrete glare screen, CALTRANS, Materials and Research, 1997.</p> <p>2) Jewell, J., et al., Vehicle Crash Tests of the Type 70 Bridge Rail, , Report No. FHWA/CA/ESC-98/06, Material Engineering and Testing Services, CALTRANS, January 1998.</p> <p>The MASH 1100C small car is larger and considered more stable than the 820C. So, the MASH vehicle should also remain stable during impacts into single slope barriers. The 1100C has been successfully redirected by safety shaped barriers, which create more vehicle climb and roll than single slope barriers, as documented in the report noted below. Thus, there is no concern for vehicle instability with the MASH 1100C impacting single slope concrete barriers.</p> <p>3) Polivka, K.A., et al., Performance Evaluation of the Permanent New Jersey Safety Shape Barrier – Update to NCHRP 350 Test No. 4-10 (2214NJ-1), Report No. TRP-03-177-06, MwRSF, University of Nebraska-Lincoln, October 13, 2006.</p> <p>The MASH 1100C car has been successfully tested when impacting a nearly rigid, steel barrier with a vertical face, as documented in the report noted below. Vertical barriers impart the highest OIV and ORA values, the single slope barrier should not cause occupant ridedown issues.</p> <p>4) Bligh, R.P., et al., Development of a MASH TL-4 Median Barrier Gate, Report No. FHWA/TX-11/9-1002-2, TTI, Texas A&M, June 2011.</p> <p>Additionally, NCHRP Web-Only Document 157 determined single-slope barriers with a 9-degree slope to be crashworthy to MASH performance standards as long as they have adequate structural capacity. Structural capacity of the bridge rail would be evaluated with test no. 5-12.</p>	Non-Critical, not conducted

Required Test Number	Narrative Description	Evaluation Results
5-11 (2270P)	<p>Previous crash testing of the 2270P pickup into an 11-degree single-sloped concrete bridge rail and a vertical-faced concrete bridge rail both resulted in successful MASH tests with minimal vehicle roll and pitch displacements as noted in the following reports:</p> <p>1) Williams, W.F., et al., MASH Test 4-11 of the TxDOT Single Slope Bridge Rail (Type SSTR) on Pan-Formed Bridge Deck, Report No. FHWA/TX-11/9-1002-3, TTI, Texas A&M University, College Station, Texas, March 2011.</p> <p>2) Schmidt, J.D., et al., Development and Testing of a New Vertical-Faced Temporary Concrete Barrier for use on Composite Panel Bridge Decks, Report No. TRP-03-220-09, MwRSF, University of Nebraska-Lincoln, Lincoln, Nebraska, October 13, 2009.</p> <p>The 9-degree slope of the Manitoba median barrier is between these two tested systems, so the vehicle performance in terms of stability and occupant risk has been effectively bracketed by the previous crash tests.</p> <p>Additionally, National Cooperative Highway Research Program (NCHRP) Web-Only Document 157 determined single-slope barriers with a 9-degree slope to be crashworthy to MASH performance standards as long as they have adequate structural capacity. Structural capacity of the bridge rail would be evaluated with test no. 5-12.</p>	Non-Critical, not conducted
5-12 (36000V)	<p>The median barrier was configured with the exact same height and face geometry as compared to the Manitoba Constrained-Width Tall Wall bridge rail. Additionally, the reinforcement of the median barrier was designed to provide a slightly greater structural capacity than the full-scale crash tested bridge rail configuration. As such, the safety performance of the median barrier should be equal to or better than the bridge rail configuration.</p> <p>The full-scale test of the bridge rail and the strength analysis for both the bridge rail and the median barrier are documented within MwRSF report no. TRP-03-356-16.</p>	Non-Critical, not conducted
5-20 (1100C)	System is not a transition	Non-Relevant Test, not conducted

5-21 (2270P)	System is not a transition	Non-Relevant Test, not conducted
5-22 (36000V)	System is not a transition	Non-Relevant Test, not conducted

Full Scale Crash Testing was done in compliance with MASH by the following accredited crash test laboratory (cite the laboratory's accreditation status as noted in the crash test reports.):

Laboratory Name:	Midwest Roadside Safety Facility	
Laboratory Signature:	Karla Lechtenberg	<small>Digitally signed by Karla Lechtenberg DN: cn=Karla Lechtenberg, o=Midwest Roadside Safety Facility (MwRSF), ou, email=kpolivka2@unl.edu, c=US Date: 2016.09.29 14:25:38 -05'00'</small>
Address:	130 Whittier Research Center, 2200 Vine Street, Lincoln, NE 68583-0853	Same as Submitter <input checked="" type="checkbox"/>
Country:	USA	Same as Submitter <input checked="" type="checkbox"/>
Accreditation Certificate Number and Dates of current Accreditation period :	A2LA Certificate Number: 2937.01, Valid to November 30, 2017	

Submitter Signature*: **Scott
Rosenbaugh**

Digitally signed by Scott Rosenbaugh
DN: cn=Scott Rosenbaugh, o=MwRSF, ou,
email=rosenbaugh2@unl.edu, c=US
Date: 2016.09.29 14:10:43 -05'00'

Submit Form

ATTACHMENTS

Attach to this form:

- 1) Additional disclosures of related financial interest as indicated above.
- 2) A copy of the full test report, video, and a Test Data Summary Sheet for each test conducted in support of this request.
- 3) A drawing or drawings of the device(s) that conform to the Task Force-13 Drawing Specifications [[Hardware Guide Drawing Standards](#)]. For proprietary products, a single isometric line drawing is usually acceptable to illustrate the product, with detailed specifications, intended use, and contact information provided on the reverse. Additional drawings (not in TF-13 format) showing details that are relevant to understanding the dimensions and performance of the device should also be submitted to facilitate our review.

FHWA Official Business Only:

Eligibility Letter		
Number	Date	Key Words

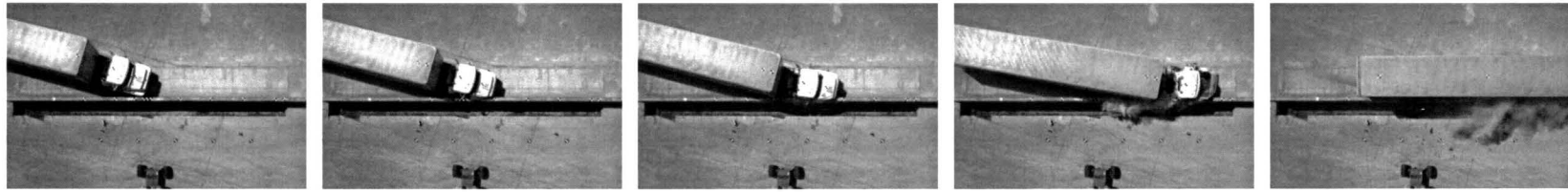

0.000 sec

0.102 sec

0.188 sec

0.386 sec

0.776 sec

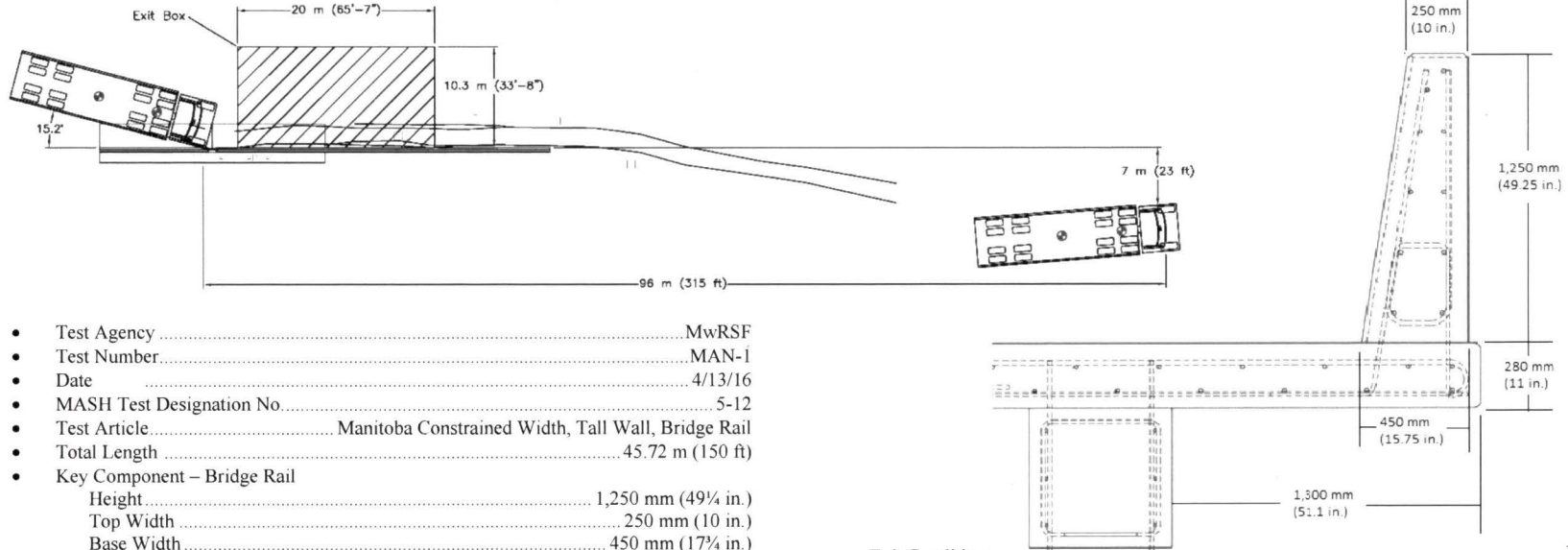

19

- Test Agency MwRSF
- Test Number MAN-1
- Date 4/13/16
- MASH Test Designation No 5-12
- Test Article Manitoba Constrained Width, Tall Wall, Bridge Rail
- Total Length 45.72 m (150 ft)
- Key Component – Bridge Rail
 - Height 1,250 mm (49¼ in.)
 - Top Width 250 mm (10 in.)
 - Base Width 450 mm (17¾ in.)
 - Open Joint Width 168 mm (6⅝ in.)
 - Steel Cover Plate Thickness 13 mm (½ in.)
- Key Component – Bridge Deck
 - Thickness 280 mm (11 in.)
 - Overhang Distance 1,300 mm (51¼ in.)
 - Open Joint Width 19 mm (¾ in.)
- Vehicle Make /Model 2004 International 9200 Tractor, 2001 Wabash National Trailer
 - Curb 13,481 kg (29,720 lb)
 - Test Inertial 36,322 kg (80,076 lb)
 - Gross Static 36,322 kg (80,076 lb)
- Impact Conditions
 - Speed 83.2 km/h (51.7 mph)
 - Angle 15.2 deg.
 - Impact Location 0.46 m (1.5 ft) upstream from open joint
- Impact Severity (IS) 664 kJ (490 kip-ft) > 548 kJ (404 kip-ft) limit from MASH
- Vehicle Stability Satisfactory

- Exit Conditions
 - Speed 61.6 km/h (38.3 mph)
 - Angle 0 deg.
- Exit Box Criterion Pass
- Vehicle Stopping Distance 96 m (315 ft)
- Vehicle Damage Moderate
 - Vehicle Damage Scale [30] IFR-6 and 1-RP-1
 - Collision Deformation Classification [31] 1-FREW3 and 1-RDES1
- Maximum Vehicle Roll
 - Cab 16.4 deg.
 - Trailer 13.3 deg.
- Test Article Damage Minimal Cracking and Spalling
- Maximum Test Article Deflections
 - Permanent Set 0 mm (0 in.)
 - Dynamic 52 mm (2 in.)
 - Working Width 949 mm (37.4 in.)

Figure 35. Summary of Test Results and Sequential Photographs, Test No. MAN-1

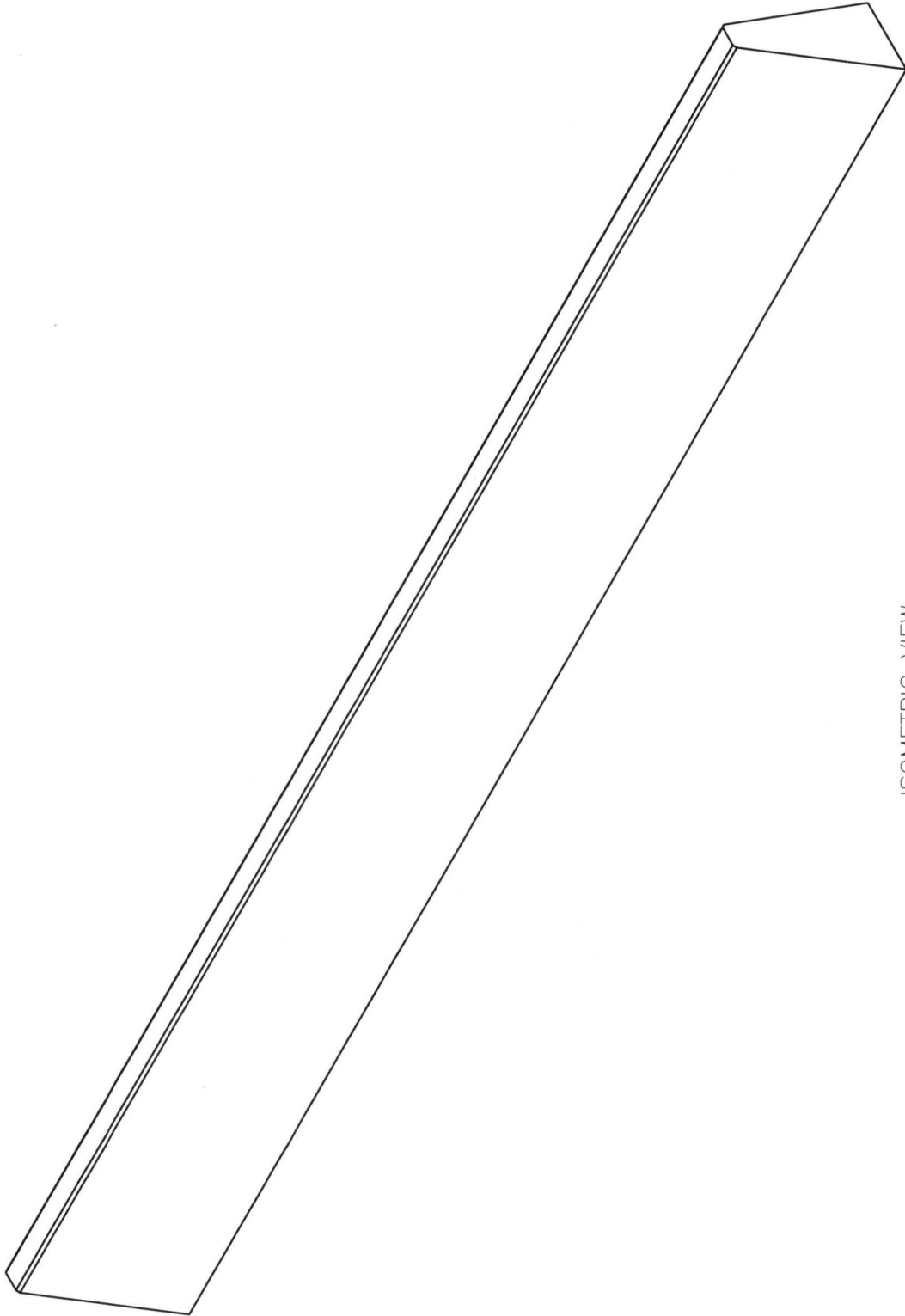

ISOMETRIC VIEW

MANITOBA CONSTRAINED-WIDTH, TALL WALL - MEDIAN



SSS##a-c

SHEET NO.

DATE:

1 of 7

9/27/2016

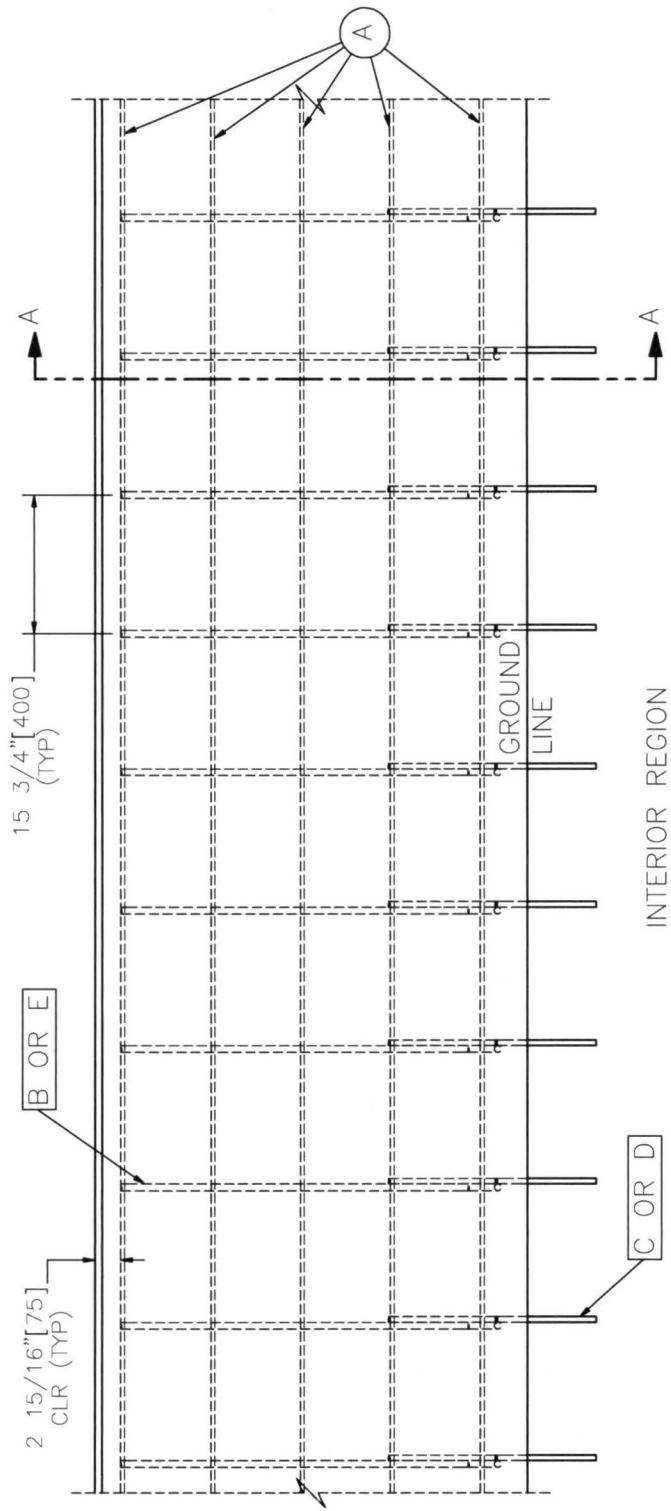

NOTES:

- (1) A MINIMUM OVERLAP OF 24" [610] IS TO BE USED FOR ALL LONGITUDINAL REBAR.
- (2) END SECTION REINFORCEMENT SPACING OF BAR B IS 11 13/16" [300] INSTEAD OF 15 3/4" [400] AND SHOULD EXTEND FOR A MINIMUM LENGTH OF 109 5/8" [2785] ADJACENT TO DISCONTINUITIES.

MANITOBA CONSTRAINED-WIDTH, TALL WALL - MEDIAN



SSS##a-c

SHEET NO.	DATE:
3 of 7	9/27/2016

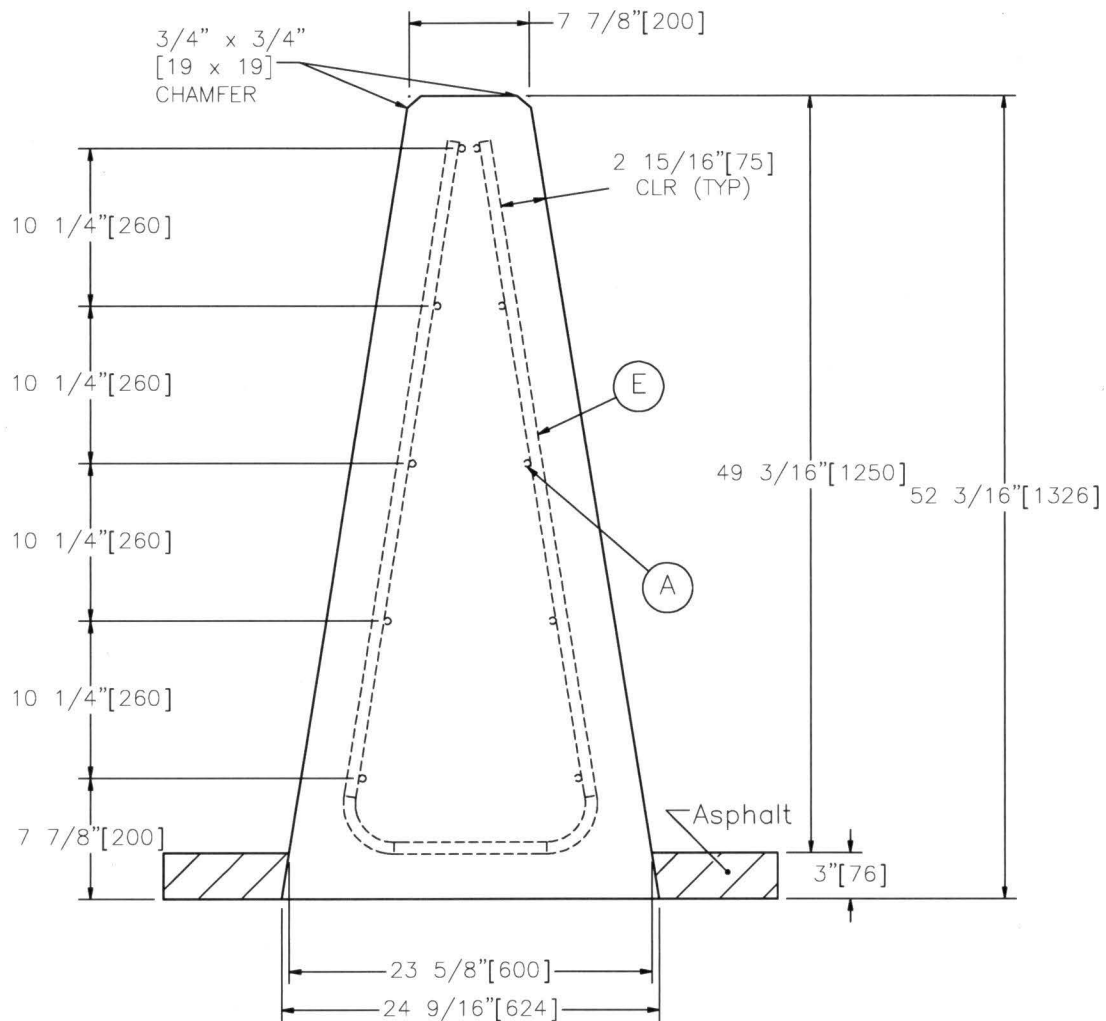

SECTION A-A
OPTION C
ASPHALT KEYWAY ANCHORAGE

NOTES:

- (1) END SECTIONS STILL REQUIRE ANCHORAGE TO FOUNDATION SLAB VIA OPTIONS A OR B.
- (2) 2 15/16" [75] CLEAR COVER FOR ALL REBAR.

MANITOBA CONSTRAINED-WIDTH, TALL WALL - MEDIAN



SSS##a-c

SHEET NO.

DATE:

5 of 7

9/27/2016

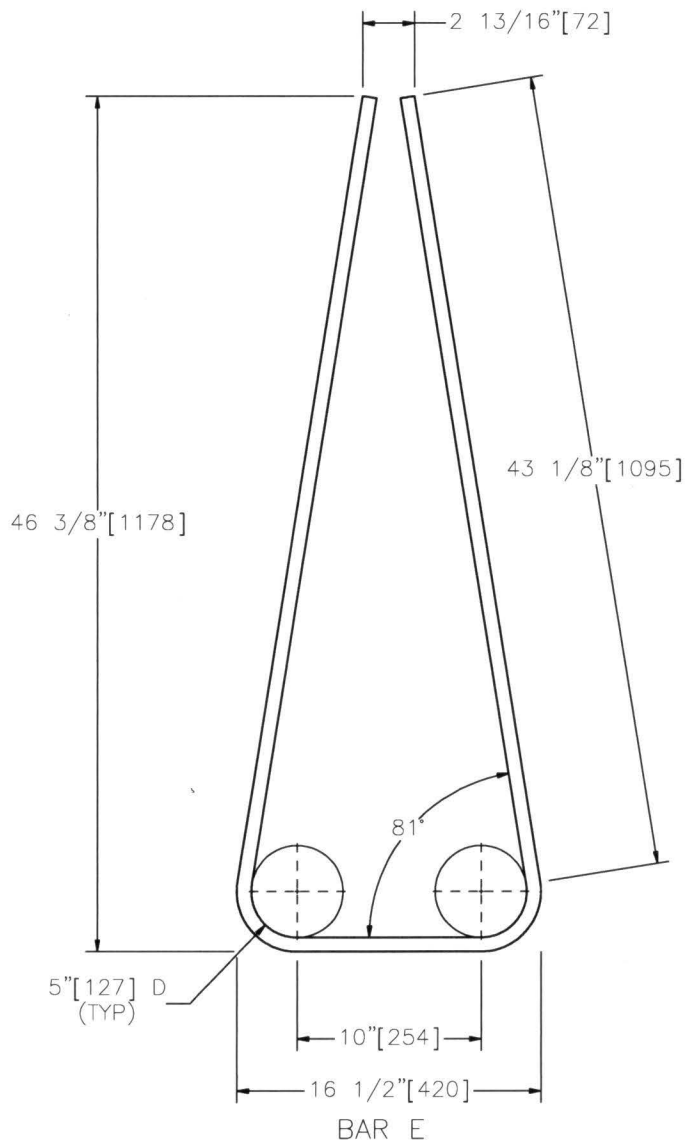

BAR	SYSTEM	QUANTITY	SIZE	LENGTH	MATERIAL
E	c	10	20M	106 3/16" [2,698]	CANADIAN METRIC GR. 400W

MANITOBA CONSTRAINED-WIDTH, TALL WALL - MEDIAN



SSS##a-c

SHEET NO.

DATE:

7 of 7

9/27/2016