



U.S. Department  
of Transportation  
**Federal Highway  
Administration**

1200 New Jersey Ave., SE  
Washington, D.C. 20590

February 9, 2018

In Reply Refer To:  
HSST-1/B-299

Mr. Gerrit A. Dyke, P.E.  
Lindsay Transportation Solutions, Inc.  
180 River Road  
Rio Vista, CA 95471

Dear Mr. Dyke:

This letter is in response to your December 6, 2017 request for the Federal Highway Administration (FHWA) to review a roadside safety device, hardware, or system for eligibility for reimbursement under the Federal-aid highway program. This FHWA letter of eligibility is assigned FHWA control number B-299 and is valid until a subsequent letter is issued by FHWA that expressly references this device.

### **Decision**

The following device is eligible within the length-of-need, with details provided in the form which is attached as an integral part of this letter:

- RTS Guard

### **Scope of this Letter**

To be found eligible for Federal-aid funding, new roadside safety devices should meet the crash test and evaluation criteria contained in the American Association of State Highway and Transportation Officials' (AASHTO) Manual for Assessing Safety Hardware (MASH). However, the FHWA, the Department of Transportation, and the United States Government do not regulate the manufacture of roadside safety devices. Eligibility for reimbursement under the Federal-aid highway program does not establish approval, certification or endorsement of the device for any particular purpose or use.

This letter is not a determination by the FHWA, the Department of Transportation, or the United States Government that a vehicle crash involving the device will result in any particular outcome, nor is it a guarantee of the in-service performance of this device. Proper manufacturing, installation, and maintenance are required in order for this device to function as tested.

This finding of eligibility is limited to the crashworthiness of the system and does not cover other structural features, nor conformity with the Manual on Uniform Traffic Control Devices.

### **Eligibility for Reimbursement**

Based solely on a review of crash test results and certifications submitted by the manufacturer, and the crash test laboratory, FHWA agrees that the device described herein meets the crash test and evaluation criteria of the AASHTO's MASH. Therefore, the device is eligible for reimbursement under the Federal-aid highway program if installed under the range of tested conditions.

Name of system: RTS Guard  
Type of system: Longitudinal Barrier  
Test Level: MASH Test Level 3 (TL3)  
Testing conducted by: Safe Technologies, Inc.  
Date of request: December 6, 2017  
Date initially acknowledged: December 6, 2017

FHWA concurs with the recommendation of the accredited crash testing laboratory on the attached form.

### **Full Description of the Eligible Device**

The device and supporting documentation, including reports of the crash tests or other testing done, videos of any crash testing, and/or drawings of the device, are described in the attached form.

### **Notice**

This eligibility letter is issued for the subject device as tested. Modifications made to the device are not covered by this letter. Any modifications to this device should be submitted to the user (i.e., state DOT) as per their requirements.

You are expected to supply potential users with sufficient information on design, installation and maintenance requirements to ensure proper performance.

You are expected to certify to potential users that the hardware furnished has the same chemistry, mechanical properties, and geometry as that submitted for review, and that it will meet the test and evaluation criteria of AASHTO's MASH.

Issuance of this letter does not convey property rights of any sort or any exclusive privilege. This letter is based on the premise that information and reports submitted by you are accurate and correct. We reserve the right to modify or revoke this letter if: (1) there are any inaccuracies in the information submitted in support of your request for this letter, (2) the qualification testing was flawed, (3) in-service performance or other information reveals safety problems, (4) the system is significantly different from the version that was crash tested, or (5) any other information indicates that the letter was issued in error or otherwise does not reflect full and

complete information about the crashworthiness of the system.

**Standard Provisions**

- To prevent misunderstanding by others, this letter of eligibility designated as FHWA control number B-299 shall not be reproduced except in full. This letter and the test documentation upon which it is based are public information. All such letters and documentation may be reviewed upon request.
- This letter shall not be construed as authorization or consent by the FHWA to use, manufacture, or sell any patented system for which the applicant is not the patent holder.
- If the subject device is a patented product it may be considered to be proprietary. If proprietary systems are specified by a highway agency for use on Federal-aid projects: (a) they must be supplied through competitive bidding with equally suitable unpatented items; (b) the highway agency must certify that they are essential for synchronization with the existing highway facilities or that no equally suitable alternative exists; or (c) they must be used for research or for a distinctive type of construction on relatively short sections of road for experimental purposes. Our regulations concerning proprietary products are contained in Title 23, Code of Federal Regulations, Section 635.411.

Sincerely,



Michael S. Griffith  
Director, Office of Safety Technologies  
Office of Safety

Enclosures



## Request for Federal Aid Reimbursement Eligibility of Highway Safety Hardware

<b>Submitter</b>	Date of Request:	December 06, 2017	<input checked="" type="radio"/> New <input type="radio"/> Resubmission
	Name:	Gerrit A. Dyke, P.E.	
	Company:	Lindsay Transportation Solutions, Inc.	
	Address:	180 River Road, Rio Vista, CA 95471	
	Country:	USA	
	To:	Michael S. Griffith, Director FHWA, Office of Safety Technologies	

I request the following devices be considered eligible for reimbursement under the Federal-aid highway program.

**Device & Testing Criterion** - Enter from right to left starting with Test Level

!-!-!

System Type	Submission Type	Device Name / Variant	Testing Criterion	Test Level
'B': Rigid/Semi-Rigid Barriers (Roadside, Median, Bridge Railings)	<input checked="" type="radio"/> Physical Crash Testing <input type="radio"/> Engineering Analysis	RTS Guard	AASHTO MASH	TL3

By submitting this request for review and evaluation by the Federal Highway Administration, I certify that the product(s) was (were) tested in conformity with the AASHTO Manual for Assessing Safety Hardware and that the evaluation results meet the appropriate evaluation criteria in the MASH.

**Individual or Organization responsible for the product:**

Contact Name:	Gerrit A. Dyke, P.E.	Same as Submitter <input checked="" type="checkbox"/>
Company Name:	Lindsay Transportation Solutions, Inc.	Same as Submitter <input checked="" type="checkbox"/>
Address:	180 River Road, Rio Vista, CA 95471	Same as Submitter <input checked="" type="checkbox"/>
Country:	USA	Same as Submitter <input checked="" type="checkbox"/>

Enter below all disclosures of financial interests as required by the FHWA 'Federal-Aid Reimbursement Eligibility Process for Safety Hardware Devices' document.

Safe Technologies, Inc. (STI) performs testing and analysis services for Lindsay Transportation Solutions, Inc. (LTS). STI is a wholly owned subsidiary of LTS. STI is a fully accredited crash test facility to ISO 17025 by A2LA and is recognized by the US Federal Highway Administration (FHWA) to perform full scale crash tests per NCHRP Report 350 and MASH criteria.

The STI laboratory manager, technicians, and laborers are compensated by LTS for salaries and wages. STI and staff does not receive any incentives, compensation, commissions, or professional fees corresponding to the outcome of any testing or analysis.

STI or staff does not receive any research funding or other research support from LTS. STI and staff also do not have any financial interest in patents, copyrights, or other intellectual property associated with the products they test or analyze.

KARCO Engineering, LLC. was contracted by LTS to collaborate with STI for this testing program. KARCO provided guidance, recommendations, and suggestions for testing and reporting practices. KARCO reviewed test data and reports to ensure accuracy and correct representation of test parameters and results. KARCO nor any KARCO employee has any financial interest in LTS, STI, or the product being tested.

## PRODUCT DESCRIPTION

New Hardware or Significant Modification
  Modification to Existing Hardware

The RTS Guard is a polyethylene height extension for concrete and steel barrier. The RTS Guard is designed to complement MASH Test Level 3 impact performance and vehicle containment of concrete and steel barriers by providing improved containment and protection to pedestrians and cyclists who may interact with the barrier. In addition, the RTS Guard provides glare and gawk screen benefits. The RTS Guard is designed to exceed typical hand rail standards while remaining intact and limiting debris during vehicle impacts. The RTS Guard may be applied to the QuickChange Moveable Barrier Concrete Reactive Tension System (QMB-CRTS) or similar barrier systems.

The RTS Guard is comprised of a polyethylene segment measuring approximately 11 3/8 in [0.3m] wide, 35 1/2 in [0.9m] long and 10 3/16 in [0.3m] tall. The segment is fastened to the tops of concrete or steel barriers using concrete anchors or hardware. When applied to a 32" [0.8m], the RTS Guard provides a nominal 42" [1.0m] barrier system.

Enclosure A includes several details regarding RTS Guard applications and variations including the application of decals and ID codes, mounting hardware, barrier applications, polyethylene material variations and color options.

Manufacturing drawings may be adjusted to ensure manufacturing capability and consistency with MASH tested and certified product.

## CRASH TESTING

By signature below, the Engineer affiliated with the testing laboratory, agrees in support of this submission that all of the critical and relevant crash tests for this device listed above were conducted to meet the MASH test criteria. The Engineer has determined that no other crash tests are necessary to determine the device meets the MASH criteria.

Engineer Name:	Joseph Nagy	
Engineer Signature:	<b>Joseph Nagy</b>	Digitally signed by Joseph Nagy Date: 2017.12.06 15:07:28 -08'00'
Address:	170 River Road, Rio Vista, CA 94571	Same as Submitter <input type="checkbox"/>
Country:	USA	Same as Submitter <input type="checkbox"/>

A brief description of each crash test and its result:

Required Test Number	Narrative Description	Evaluation Results
3-10 (1100C)	<p>The system was judged to have successfully met all of the evaluation criteria for MASH Test 3-10 without any adverse effect caused by the addition of the RTS Guard.</p> <p>The QMB-CRTS barrier equipped with the RTS Guard satisfied the MASH structural adequacy criteria for its intended function as a longitudinal barrier. The test article redirected the 1100C vehicle in a controlled manner. The vehicle did not penetrate, underride, or override the installation. The test article exhibited some permanent and dynamic deflection in the test.</p> <p>The QMB-CRTS barrier equipped with the RTS Guard satisfied all occupant risk criteria. Theoretical occupant impact velocities in the longitudinal and lateral directions were below the preferred limit of 30.0 ft/s (9.1 m/s). Ridedown accelerations in the longitudinal and lateral directions were well below the preferred limit of 15.0 G. There was no test article debris detached during the test.</p> <p>There was minimal deformation to the occupant compartment of the 1100C test vehicle. There was no intrusion into the occupant compartment. The test vehicle remained upright during and after the collision with minor roll and pitch.</p> <p>The QMB-CRTS barrier equipped with the RTS Guard was judged as satisfying the applicable vehicle trajectory criteria specified in MASH without any adverse effect caused by the addition of the RTS Guard.</p>	PASS



Required Test Number	Narrative Description	Evaluation Results
3-11 (2270P)	<p>The system was judged to have successfully met all of the evaluation criteria for MASH Test 3-11 without any adverse effect caused by the addition of the RTS Guard.</p> <p>The QMB-CRTS barrier equipped with the RTS Guard satisfied the MASH structural adequacy criteria for its intended function as a longitudinal barrier. The test article redirected the 2270P vehicle in a controlled manner. The vehicle did not penetrate, underride, or override the installation. The test article exhibited controlled permanent and dynamic deflection in the test.</p> <p>The QMB-CRTS barrier equipped with the RTS Guard satisfied all occupant risk criteria. Theoretical occupant impact velocities in the longitudinal and lateral directions were well below the preferred limit of 30.0 ft/s (9.1 m/s). Ridedown accelerations in the longitudinal and lateral directions were well below the preferred limit of 15.0 G. There was no test article debris detached during the test.</p> <p>There was minimal deformation to the occupant compartment of the 2270P test vehicle. There was no intrusion into the occupant compartment. The test vehicle remained upright during and after the collision with minor roll and pitch.</p> <p>The QMB-CRTS barrier equipped with the RTS Guard was judged as satisfying the applicable vehicle trajectory criteria specified in MASH without any adverse effect caused by the addition of the RTS Guard.</p>	PASS
3-20 (1100C)	Optional Test not performed. CRTS is a stand alone barrier system that will not transition to any stiffer or more rigid barrier systems. Therefore, test 3-20 is not required.	Non-Relevant Test, not conducted
3-21 (2270P)	Test not performed. CRTS is a stand alone barrier system that will not transition to any stiffer or more rigid barrier systems. Therefore, test 3-21 is not required.	Non-Relevant Test, not conducted

Full Scale Crash Testing was done in compliance with MASH by the following accredited crash test laboratory (cite the laboratory's accreditation status as noted in the crash test reports.):

Laboratory Name:	Safe Technologies, Inc.	
Laboratory Signature:	<b>Joseph Nagy</b>	Digitally signed by Joseph Nagy Date: 2017.12.06 15:09:02 -08'00'
Address:	170 River Road, Rio Vista, CA 94571	Same as Submitter <input type="checkbox"/>
Country:	USA	Same as Submitter <input type="checkbox"/>
Accreditation Certificate Number and Dates of current Accreditation period :	1851.01, Valid through March 31, 2018	

Submitter Signature\*: **Gerrit Dyke**  
Digitally signed by Gerrit Dyke  
Date: 2017.12.06 15:09:33  
-08'00'

Submit Form

## ATTACHMENTS

Attach to this form:

- 1) Additional disclosures of related financial interest as indicated above.
- 2) A copy of the full test report, video, and a Test Data Summary Sheet for each test conducted in support of this request.
- 3) A drawing or drawings of the device(s) that conform to the Task Force-13 Drawing Specifications [[Hardware Guide Drawing Standards](#)]. For proprietary products, a single isometric line drawing is usually acceptable to illustrate the product, with detailed specifications, intended use, and contact information provided on the reverse. Additional drawings (not in TF-13 format) showing details that are relevant to understanding the dimensions and performance of the device should also be submitted to facilitate our review.

**FHWA Official Business Only:**

Eligibility Letter		Key Words
Number	Date	



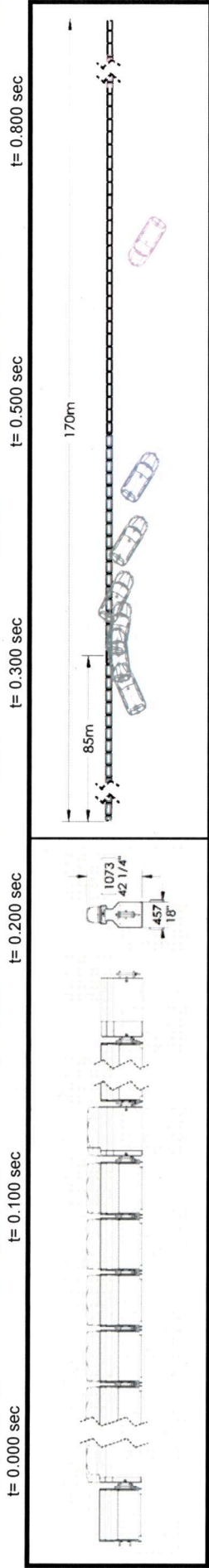
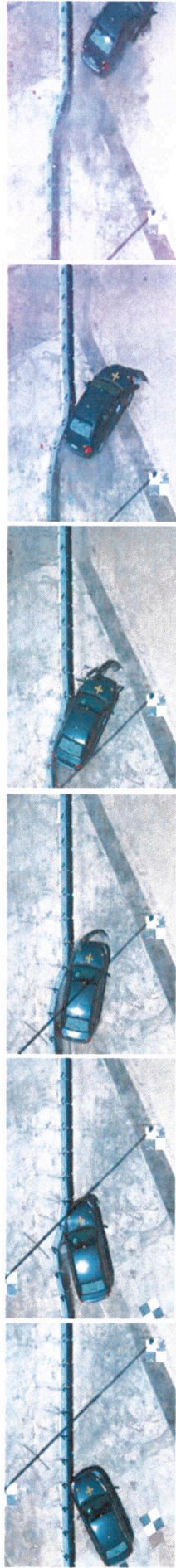

**General Information**

Test Agency..... **SAFE TECHNOLOGIES, INC.**  
 Test Number..... QMBBT310  
 Test Designation..... MASH 3-10  
 Date..... 7/19/2017

**Test Article**

Name..... Lindsay Transportation Solutions  
 Type..... RTS Guard  
 Installation Length..... 557.7 ft (170 m)  
 Segment Length..... 39.4 in (1 m)  
 Width..... 18 in (457 mm)  
 Height..... 42.25 in (1,073 mm)

**Test Vehicle**

Type / Designation..... 1100C  
 Make and Model..... 2011 Hyundai Accent  
 Curb Weight..... 2,473.6 lb (1,122 kg)  
 Test Inertial Weight..... 2,443.8 lb (1,108.5 kg)  
 Gross Static Weight..... 2,609.2 lb (1,183.5 kg)

**Impact Conditions**

Speed..... 62.7 mph (100.9 km/h)  
 Angle..... 25.0 deg  
 Location / Orientation..... Midpoint

**Exit Conditions**

Speed..... 44.6 mph (71.7 km/h)  
 Angle (deg)..... 14  
 Exit Box Criterion..... Pass

**Post Impact Trajectory**

Vehicle Stability..... Satisfactory  
 Stopping Distance..... 156 ft (47.6 m) downstream

**Occupant risk Values**

Longitudinal OIV..... 22.0 ft/s (6.7 m/s)  
 Lateral OIV..... 27.9 ft/s (8.5 m/s)  
 Longitudinal ORA..... 9.7 g's  
 Lateral ORA..... 12.7 g's  
 THIV..... 33.1 ft/s (10.1 m/s)  
 PHD..... 12.8 g's  
 ASI..... 2.05

**Test Article Damage:**

..... Minimal

**Test Article Deflections**

Permanent..... 30.0 in (762 mm)  
 Dynamic..... 31.2 in (792 mm)

**Vehicle Damage**

VDS..... 11-LFQ-5  
 CDC..... 11LFAS3  
 Maximum Deformation..... 1.25 in (31.8 mm)-floor pan

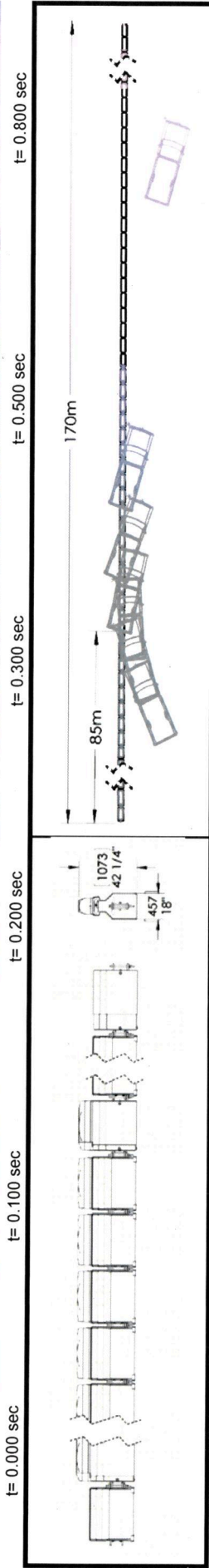
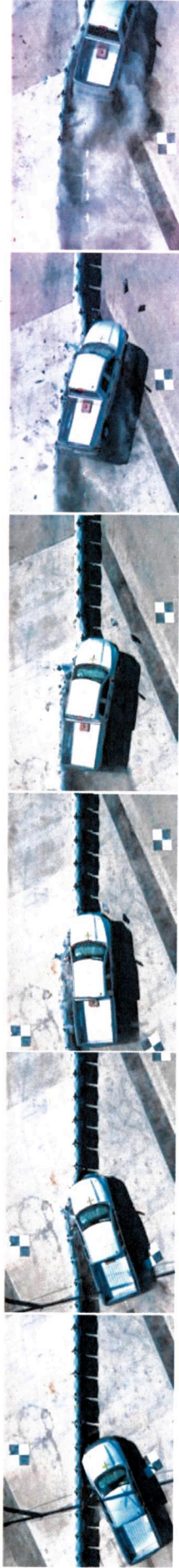

**General Information**

Test Agency..... **SAFE TECHNOLOGIES, INC.**  
 Test Number..... **QMBBT311**  
 Test Designation..... **MASH 3-11**  
 Date..... **7/18/2017**

**Test Article**

Name..... **Lindsay Transportation Solutions**  
 Type..... **RTS Guard**  
 Installation Length..... **Longitudinal Movable Barrier**  
 Segment Length..... **557.7 ft (170 m)**  
 Width..... **39.4 in (1 m)**  
 Height..... **18 in (457 mm)**  
**Test Vehicle**  
 Type / Designation..... **2270P**  
 Make and Model..... **2011 Dodge Ram 1500**  
 Curb Weight..... **4,913.0 lbs (2,228.5 kg)**  
 Test Inertial Weight..... **5,062.9 lbs (2,296.5 kg)**  
 Gross Static Weight..... **5,062.9 lbs (2,296.5 kg)**

**Impact Conditions**

Speed..... **62.9 mph (101.2 km/h)**  
 Angle..... **25.0 deg**  
 Location / Orientation..... **Midpoint**

**Exit Conditions**

Speed..... **36.2 mph (58.2 km/h)**  
 Angle (deg)..... **13.2**  
 Exit Box Criterion..... **Pass**

**Post Impact Trajectory**

Vehicle Stability..... **Satisfactory**  
 Stopping Distance..... **224.4 ft (68.4 m)**

**Occupant risk Values**

Longitudinal OIV..... **16.4 ft/s (5.0 m/s)**  
 Lateral OIV..... **16.7 ft/s (5.1 m/s)**  
 Longitudinal ORA..... **6.8 g's**  
 Lateral ORA..... **10.7 g's**  
 THIV..... **23.3 ft/s (7.1 m/s)**  
 PHD..... **11.5 g's**  
 ASI..... **1.11**

**Test Article Damage:**

Minimal

**Test Article Deflections**

Permanent..... **44.6 in (1,133 mm)**  
 Dynamic..... **48.7 in (1,237 mm)**

**Vehicle Damage**

VDS..... **11-LFQ-5**  
 CDC..... **11LFAS3**  
 Maximum Deformation..... **0.81 in (20.6 mm)-floor pan**



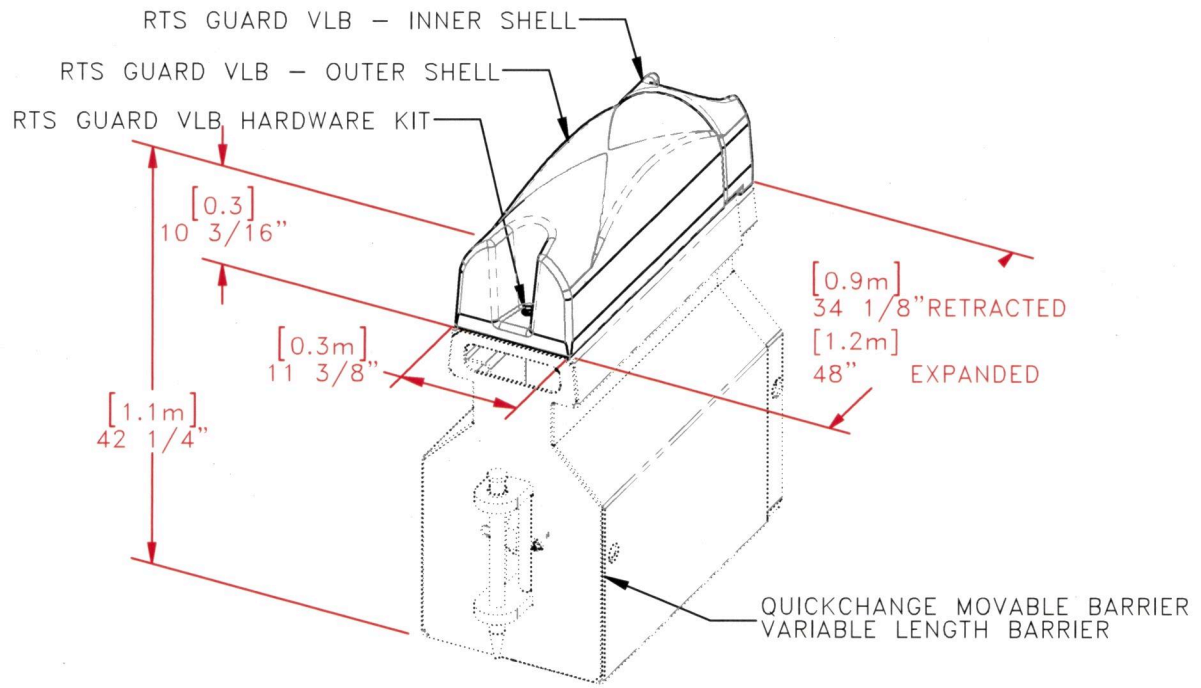
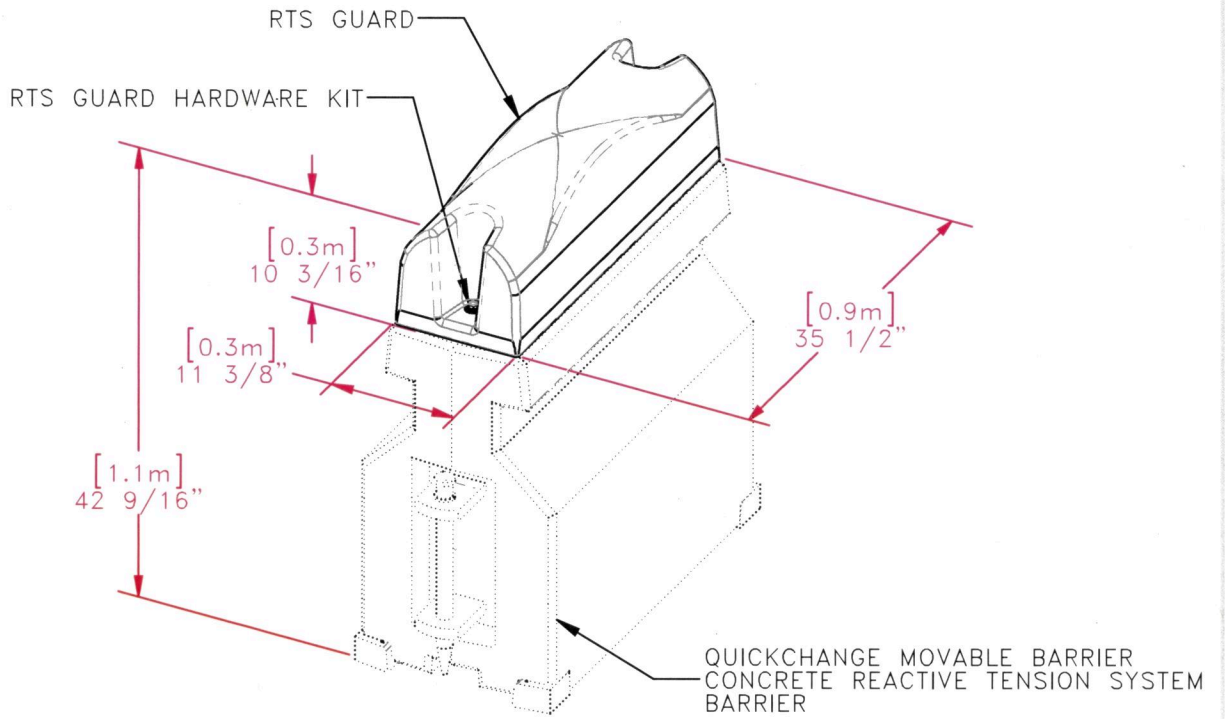

# RTS GUARD™



Lindsay Transportation Solutions, 180 River Rd., Rio Vista CA. 94571, 888-800-3691  
www.theroadzipper.com

SHEET NO.  
1 OF 2

DATE:  
XXX

## INTENDED USE

The RTS Guard™ (RTSG) is a supplementary safety device designed to enhance the MASH Test Level 3 impact performance and vehicle containment of concrete barrier by providing improved containment and protection to pedestrians and cyclists who may interact with the barrier. In addition, the RTSG provides glare and gawk screen benefits. When installed on CRTS longitudinal barrier segments, the 42" nominal system height follows design guidelines stated in AASHTO LRFD Bridge Design Specifications 13.9.2-Geometry and C13.9.2.

The CRTS barrier without RTSG has been successfully tested to MASH Test Level 3 and was issued a Federal Highway Administration (FHWA) eligibility letter under FHWA control number B-277. Crash test data shows that during a TL-3 impact with a 2270P vehicle the RTSG flexes and experiences some localized tearing directly within the impact zone while remaining attached to the barrier. Outside of the impact zone, the RTSG sees only minor deformation.

The system consists of the RTS Guard™, two screw anchors, RTS Guard™ VLB, and accompanying VLB hardware kit. The system can be installed on any QMB-CRTS barrier and respective VLB. Contact the manufacturer for further information and installation instructions.

## APPROVALS

The RTS GUARD™ has been fully tested in conformance with MASH Test Level 3 and is determined eligible for Federal reimbursement by FHWA.

FHWA Eligibility Letters: XXXXXXXX

## CONTACT INFORMATION

Lindsay Transportation Solutions  
180 River Rd.  
Rio Vista, CA 94571  
[www.barriersystemsinc.com](http://www.barriersystemsinc.com)  
Phone: 888-800-3691 or 707-374-6800  
Fax: 707-374-6801  
Email: [info@barriersystemsinc.com](mailto:info@barriersystemsinc.com)

## RTS GUARD™



SHEET NO.

DATE:

2 OF 2

Lindsay Transportation Solutions, 180 River Rd., Rio Vista CA. 94571, 888-800-3691  
[www.theroadzipper.com](http://www.theroadzipper.com)