



U.S. Department
of Transportation
**Federal Highway
Administration**

1200 New Jersey Ave., SE
Washington, D.C. 20590

December 19, 2011

In Reply Refer To:
HSST/CC-122

Mr. Barry D. Stephens, P.E.
Sr. Vice President Engineering
Energy Absorption Systems
3617 Cincinnati Avenue
Rocklin, CA 95678

Dear Mr. Stephens:

This letter is in response to your request for the Federal Highway Administration (FHWA) to review a roadside safety system for eligibility for reimbursement under the Federal-aid highway program.

Name of device: Trinity End Terminal Median (TREND™ 350 Median)
Type of device: W-Beam Redirective, Gating End Terminals
Test Level: NCHRP Report 350 Test Level 3 (TL-3)
Testing conducted by: E-Tech Testing Services, Inc.
Date of request: December 17, 2010
Date of completed package: October 26, 2011
Task Force 13 Designator: SEW26; TREND™ 350 Median

Based on a review of crash test results submitted by the manufacturer certifying the device described herein meets the crashworthiness criteria of the National Cooperative Highway Research Program (NCHRP), Report 350 testing guidelines the device is eligible for reimbursement under the Federal-aid highway program. Eligibility for reimbursement under the Federal-aid highway program does not establish approval or endorsement by FHWA for any particular purpose or use.

The FHWA, the Department of Transportation, and the United States Government do not endorse products or services and the issuance of a reimbursement eligibility letter is not an endorsement of any product or service

Requirements

Roadside safety devices should meet the guidelines contained in the National Cooperative Highway Research Program Report 350 (NCHRP Report 350). The FHWA Memorandum “ACTION: Identifying Acceptable Highway Safety Features” of July 24, 1997, provides further guidance on crash testing requirements of longitudinal barriers.

FHWA: HSST: WLongstreet: ms: x60087:12/8/11
Revised: sf:x62288:12/19/11
File: h://directory folder/HSST/ C-122 Trinity End Terminal Trend_Median. docx
cc: HSST Will Longstreet

Decision

The following device was found eligible, with details provided below:

- TREND™ 350 Median

Description

The TREND™ 350 End Terminal family of products includes the TREND™ 350 Median. This new family of products is designed to shield the end of w-beam guardrail in both roadside tangent and flared installations and double sided median installations. The tangent and flared systems are constructed from the same components with the only difference being the product's installation with or without a flare relative to the edge of road. The double-sided median system uses many of the same components as the TREND™ 350 Tangent and Flared system; however the head, head rails and rail spacers are unique to allow attachment to double-faced guardrail found in roadway medians. The beginning of length of need (BLON) for this system is cited as the third post. It should be noted that the rail and anchorage components showed their ability to redirect impacting vehicles at flare angles of up to 6 degrees during the TREND™ 350 End Terminal, Tangent and Flared test series. Since the TREND™ 350 Median system is composed of the same structural elements, this system can be installed with a flare of up to 6 degrees, which corresponds to 3 feet 6 inches for the 5 post system and 2 feet 10 inches for a system that is 4 posts in length.

The TREND™ 350 Median is based on AASHTO w-beam rail that has been modified to include slots. These slots extend the length of the rail from the guardrail bolts that hold the rail together. When an errant vehicle strikes the impact head of the terminal in an end on impact, the vehicle's energy is safely absorbed by the terminal's rail sections as each of the adjacent pairs of rail sections slide past each other. The vehicle's kinetic energy is dissipated by tearing of the panel slots, re-shaping of the panels by a calibrated fin at the back of each panel, and by friction. A lightweight impact head is attached to the front of the unit to engage impacting vehicles and to control potential vehicle spearing by the downstream guardrail.

The TREND™ 350 Median uses end terminal posts and anchorage components that were previously tested to NCHRP 350. These posts designs, known as the Hinged Breakaway Assembly (HBA) and Steel Yielding Terminal Post (SYTP), have seen extensive use in the ET family of end terminals previously accepted by the FHWA. The TREND™ 350 Median uses an HBA post in the first post position and an SYTP post in the second post position. These first two posts are joined together by another standard end terminal component, the Angle Strut. The remaining system posts are standard line posts, proven in a number of products. The TREND™ 350 Median uses two line posts, resulting in total length of 26 feet 11 inches. Past FHWA letters for the above cited components are HSA-10/CC-12F (HBA and Angle Strut), HSA-10/CC-12L (W6X8.5 SYTP), and HAS-10/CC-12Q (ET with line posts).

Details of this system are included as an enclosure to this correspondence.

Crash Testing

The following NCHRP Report 350 tests were completed for FHWA review of the TREND Median End Terminal:



TREND™ 350 Median End Terminal:



- Test 3-30 (820C/ 100kph/ 0°/ w/4 Offset):
Impact speed = 97.0 km/h, Long. ΔV = 11.3 m/s, Long. Ridedown = -18.4 g
- Test 3-31 (2000P/ 100kph/ 0°/ Nose):
Impact speed = 96.4 km/h, Long. ΔV = 8.2 m/s, Long. Ridedown = -11.3 g
- Test 3-31 (2000P/ 100kph/ 0°/ Nose):
Impact speed = 100.4 km/h, Long. ΔV = 8.4 m/s, Long. Ridedown = -10.2 g

Tests 3-32 through 3-35 and Test 3-39 were not run for the TREND™ 350 Median as the manufacturer requests these tests be waived based upon the following reasons, as stated in Table 1. In addition, it is noted that Test 3-31 for the TREND™ 350 Median End Terminal was conducted twice. This test was first run with a system that had a total five (5) posts at 33 feet 2 inches in length. This test demonstrated that the system had excess capacity and therefore Test 3-31 was re-conducted with a system that had a total of four (4) posts at 26 feet 11 inches in length. As noted above, this test also resulted in satisfactory occupant risk values.

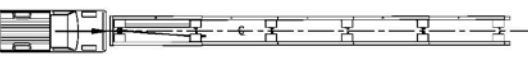
Test summaries of the above tests are included as an enclosure to this correspondence.

Table 1. Trinity End Terminal (TREND™ 350), Test Matrix

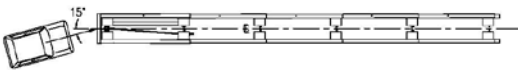
Test #	Illustration	Completed	Notes
3-30		YES	Passed all Occupant Risk Values.
3-31 (1)		YES	5-Bay System Passed all Occupant Risk Values.
3-31 (2)		YES	4-Bay System Passed all Occupant Risk Values.

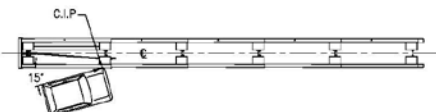
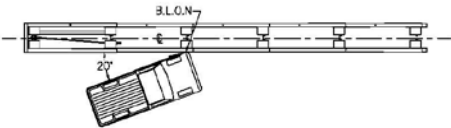
Test #	Illustration	Completed	Notes
3-32		NO	Test 3-30, which was run on the TREND™ 350 Median, is worst case for a gating energy absorbing terminal. Test 3-32 was run on the single sided system in the <u>tangent</u> configuration and this test need not be re-run.
3-33		NO	Test 3-31, which was run on the TREND™ 350 Median is worst case for a gating energy absorbing terminal. Test 3-33 was run on the single sided system in the <u>tangent</u> configuration and this test need not be re-run.
3-34		NO	This test was passed on the single sided system in the <u>tangent</u> configuration. The single sided system test is worst case, as there are less structural elements resisting the impact.
3-35		NO	This test was passed on the single sided TREND™ 350 End Terminal installed in both the <u>flared</u> and <u>tangent</u> configurations. These single sided system tests are worst case, as there are less structural elements resisting the impact.

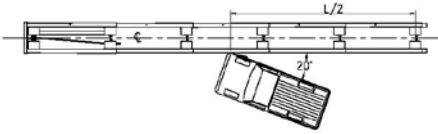
Test #	Illustration	Completed	Notes
3-39		NO	This test was passed on the single sided TREND™ 350 End Terminal in the <u>tangent</u> configuration and the structural elements the vehicle impacts have not changed. The single sided system test is worst case, as there are less structural elements resisting the impact.

Findings

Based on the successful completion of the described NCHRP Report 350 testing, FHWA concurs that the TREND™ 350 Median End Terminal meets the evaluation criteria for NCHRP Report 350 redirective, gating end terminals at TL-3 impact conditions. The FHWA also concurs with the request for a testing waiver of NCHRP Report 350 test numbers 3-32, 3-33, 3-34, 3-35, and 3-39 and the provided reasons for the waiver for each of these test numbers as stated within this correspondence.

In addition, FHWA concurs that the testing of the TREND™ 350 End Terminal family of end terminals was conducted at the worst-case guardrail height of 27-3/4 inches and it is acceptable to use the TREND™ 350 Median End Terminal when attached to guardrail with heights between 27-3/4 inches and 31 inches (SGM04a-b from 27 ¾ inches to 30 inches, MGS from 27 ¾ inches to 31 inches, and the various proprietary 31-inch designs.)

The FHWA also notes that the rail and anchorage components showed their ability to redirect impacting vehicles at flare angles of up to 6 degrees during the TREND™ 350 End Terminal, Tangent and Flared test series. Since the TREND™ 350 Median system is composed of the same structural elements, this system can be installed with a flare of up to 6 degrees, which corresponds to 3 feet 6 inches for the 5 post system and 2 feet 10 inches for a system that is 4 posts in length.

Therefore, these systems as described are eligible for reimbursement and should be installed under the range of conditions tested, when such use is acceptable to a highway agency.

Please note the following standard provisions that apply to the FHWA eligibility letters:

- This letter includes an AASHTO/ARTBA/AGC Task Force 13 designator that should be used to identify any new or updated Task Force 13 drawings.
- This finding of eligibility is limited to the crashworthiness characteristics of the devices and does not cover their structural features, or conformity with the Manual on Uniform Traffic Control Devices.

- Any changes that may influence the crashworthiness of the device will require a new reimbursement eligibility letter.
- Should the FHWA discover that the qualification testing was flawed, that in-service performance reveals unacceptable safety problems, or that the device being marketed is significantly different from the version that was crash tested, we reserve the right to modify or revoke this letter.
- You will be expected to supply potential users with sufficient information on design and installation requirements to ensure proper performance.
- You will be expected to certify to potential users that the hardware furnished has the same chemistry, mechanical properties, and geometry as that submitted for review, and that it will meet the crashworthiness requirements of the NCHRP Report 350.
- To prevent misunderstanding by others, this letter is designated as number CC-122, and shall not be reproduced except in full. This letter and the test documentation upon which it is based are public information. All such letters and documentation may be reviewed at our office upon request.
- The TREND™ 350 Median is a patented product and considered proprietary. If proprietary devices are specified by highway agency for use on Federal-aid projects, (a) they must be supplied through competitive bidding with equally suitable unpatented items: (b) the highway agency must certify that they are essential for synchronization with the existing highway facilities or that no equally suitable alternative exists: or (c) they must be used for research or for a distinctive type of construction on relatively short sections of road for experimental purposes. Our regulations concerning proprietary products are contained in Title 23, Code of Federal Regulations, Section 635.411.
- This letter shall not be construed as authorization or consent by the FHWA to use, manufacture, or sell any patented device for which the applicant is not the patent holder. The finding of eligibility is limited to the crashworthiness characteristics of the candidate device, and the FHWA is neither prepared nor required to become involved in issues concerning patent law. Patent issues, if any, are to be resolved by the applicant.

Sincerely yours,

Michael S. Griffith
Director, Office of Safety Technologies
Office of Safety

Enclosures



U.S. Department
of Transportation
**Federal Highway
Administration**

1200 New Jersey Ave., SE
Washington, D.C. 20590

December 19, 2011

In Reply Refer To:
HSST/CC-122

Mr. Barry D. Stephens, P.E.
Sr. Vice President Engineering
Energy Absorption Systems
3617 Cincinnati Avenue
Rocklin, CA 95678

Dear Mr. Stephens:

This letter is in response to your request for the Federal Highway Administration (FHWA) to review a roadside safety system for eligibility for reimbursement under the Federal-aid highway program.

Name of device:	Trinity End Terminal Median (TREND™ 350 Median)
Type of device:	W-Beam Redirective, Gating End Terminals
Test Level:	NCHRP Report 350 Test Level 3 (TL-3)
Testing conducted by:	E-Tech Testing Services, Inc.
Date of request:	December 17, 2010
Date of completed package:	October 26, 2011
Task Force 13 Designator:	SEW26; TREND™ 350 Median

Based on a review of crash test results submitted by the manufacturer certifying the device described herein meets the crashworthiness criteria of the National Cooperative Highway Research Program (NCHRP), Report 350 testing guidelines the device is eligible for reimbursement under the Federal-aid highway program. Eligibility for reimbursement under the Federal-aid highway program does not establish approval or endorsement by FHWA for any particular purpose or use.

The FHWA, the Department of Transportation, and the United States Government do not endorse products or services and the issuance of a reimbursement eligibility letter is not an endorsement of any product or service

Requirements

Roadside safety devices should meet the guidelines contained in the National Cooperative Highway Research Program Report 350 (NCHRP Report 350). The FHWA Memorandum "**ACTION**: Identifying Acceptable Highway Safety Features" of July 24, 1997, provides further guidance on crash testing requirements of longitudinal barriers.

Decision

The following device was found eligible, with details provided below:

- TREND™ 350 Median

Description

The TREND™ 350 End Terminal family of products includes the TREND™ 350 Median. This new family of products is designed to shield the end of w-beam guardrail in both roadside tangent and flared installations and double sided median installations. The tangent and flared systems are constructed from the same components with the only difference being the product's installation with or without a flare relative to the edge of road. The double-sided median system uses many of the same components as the TREND™ 350 Tangent and Flared system; however the head, head rails and rail spacers are unique to allow attachment to double-faced guardrail found in roadway medians. The beginning of length of need (BLON) for this system is cited as the third post. It should be noted that the rail and anchorage components showed their ability to redirect impacting vehicles at flare angles of up to 6 degrees during the TREND™ 350 End Terminal, Tangent and Flared test series. Since the TREND™ 350 Median system is composed of the same structural elements, this system can be installed with a flare of up to 6 degrees, which corresponds to 3 feet 6 inches for the 5 post system and 2 feet 10 inches for a system that is 4 posts in length.

The TREND™ 350 Median is based on AASHTO w-beam rail that has been modified to include slots. These slots extend the length of the rail from the guardrail bolts that hold the rail together. When an errant vehicle strikes the impact head of the terminal in an end on impact, the vehicle's energy is safely absorbed by the terminal's rail sections as each of the adjacent pairs of rail sections slide past each other. The vehicle's kinetic energy is dissipated by tearing of the panel slots, re-shaping of the panels by a calibrated fin at the back of each panel, and by friction. A lightweight impact head is attached to the front of the unit to engage impacting vehicles and to control potential vehicle spearing by the downstream guardrail.

The TREND™ 350 Median uses end terminal posts and anchorage components that were previously tested to NCHRP 350. These posts designs, known as the Hinged Breakaway Assembly (HBA) and Steel Yielding Terminal Post (SYTP), have seen extensive use in the ET family of end terminals previously accepted by the FHWA. The TREND™ 350 Median uses an HBA post in the first post position and an SYTP post in the second post position. These first two posts are joined together by another standard end terminal component, the Angle Strut. The remaining system posts are standard line posts, proven in a number of products. The TREND™ 350 Median uses two line posts, resulting in total length of 26 feet 11 inches. Past FHWA letters for the above cited components are HSA-10/CC-12F (HBA and Angle Strut), HSA-10/CC-12L (W6X8.5 SYTP), and HAS-10/CC-12Q (ET with line posts).

Details of this system are included as an enclosure to this correspondence.

Crash Testing

The following NCHRP Report 350 tests were completed for FHWA review of the TREND Median End Terminal:

TREND™ 350 Median End Terminal:



- Test 3-30 (820C/ 100kph/ 0°/ w/4 Offset):
Impact speed = 97.0 km/h, Long. ΔV = 11.3 m/s, Long. Ridedown = -18.4 g
- Test 3-31 (2000P/ 100kph/ 0°/ Nose):
Impact speed = 96.4 km/h, Long. ΔV = 8.2 m/s, Long. Ridedown = -11.3 g
- Test 3-31 (2000P/ 100kph/ 0°/ Nose):
Impact speed = 100.4 km/h, Long. ΔV = 8.4 m/s, Long. Ridedown = -10.2 g

Tests 3-32 through 3-35 and Test 3-39 were not run for the TREND™ 350 Median as the manufacturer requests these tests be waived based upon the following reasons, as stated in Table 1. In addition, it is noted that Test 3-31 for the TREND™ 350 Median End Terminal was conducted twice. This test was first run with a system that had a total five (5) posts at 33 feet 2 inches in length. This test demonstrated that the system had excess capacity and therefore Test 3-31 was re-conducted with a system that had a total of four (4) posts at 26 feet 11 inches in length. As noted above, this test also resulted in satisfactory occupant risk values.

Test summaries of the above tests are included as an enclosure to this correspondence.

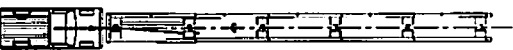
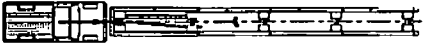
Table 1. Trinity End Terminal (TREND™ 350), Test Matrix

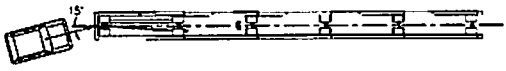
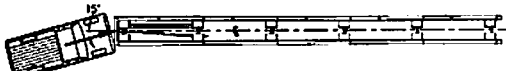
Test #	Illustration	Completed	Notes
3-30		YES	Passed all Occupant Risk Values.
3-31 (1)		YES	5-Bay System Passed all Occupant Risk Values.
3-31 (2)		YES	4-Bay System Passed all Occupant Risk Values.

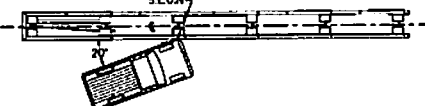
Test #	Illustration	Completed	Notes
3-32		NO	<p>Test 3-30, which was run on the TREND™ 350 Median, is worst case for a gating energy absorbing terminal. Test 3-32 was run on the single sided system in the <u>tangent</u> configuration and this test need not be re-run.</p>
3-33		NO	<p>Test 3-31, which was run on the TREND™ 350 Median is worst case for a gating energy absorbing terminal. Test 3-33 was run on the single sided system in the <u>tangent</u> configuration and this test need not be re-run.</p>
3-34		NO	<p>This test was passed on the single sided system in the <u>tangent</u> configuration. The single sided system test is worst case, as there are less structural elements resisting the impact.</p>
3-35		NO	<p>This test was passed on the single sided TREND™ 350 End Terminal installed in both the <u>flared</u> and <u>tangent</u> configurations. These single sided system tests are worst case, as there are less structural elements resisting the impact.</p>

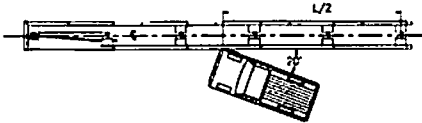
Test #	Illustration	Completed	Notes
3-39	 <p>The illustration shows a side view of a single-sided end terminal assembly. A vehicle is shown impacting the terminal from the left. The terminal consists of a horizontal rail supported by vertical posts. A dimension line labeled 'L/2' indicates the length of the terminal. A small inset diagram shows a perspective view of the terminal's end.</p>	NO	This test was passed on the single sided TREND™ 350 End Terminal in the <u>tangent</u> configuration and the structural elements the vehicle impacts have not changed. The single sided system test is worst case, as there are less structural elements resisting the impact.

Findings

Based on the successful completion of the described NCHRP Report 350 testing, FHWA concurs that the TREND™ 350 Median End Terminal meets the evaluation criteria for NCHRP Report 350 redirective, gating end terminals at TL-3 impact conditions. The FHWA also concurs with the request for a testing waiver of NCHRP Report 350 test numbers 3-32, 3-33, 3-34, 3-35, and 3-39 and the provided reasons for the waiver for each of these test numbers as stated within this correspondence.

In addition, FHWA concurs that the testing of the TREND™ 350 End Terminal family of end terminals was conducted at the worst-case guardrail height of 27-3/4 inches and it is acceptable to use the TREND™ 350 Median End Terminal when attached to guardrail with heights between 27-3/4 inches and 31 inches (SGM04a-b from 27 3/4 inches to 30 inches, MGS from 27 3/4 inches to 31 inches, and the various proprietary 31-inch designs.)

The FHWA also notes that the rail and anchorage components showed their ability to redirect impacting vehicles at flare angles of up to 6 degrees during the TREND™ 350 End Terminal, Tangent and Flared test series. Since the TREND™ 350 Median system is composed of the same structural elements, this system can be installed with a flare of up to 6 degrees, which corresponds to 3 feet 6 inches for the 5 post system and 2 feet 10 inches for a system that is 4 posts in length.

Therefore, these systems as described are eligible for reimbursement and should be installed under the range of conditions tested, when such use is acceptable to a highway agency. Please note the following standard provisions that apply to the FHWA eligibility letters:

- This letter includes an AASHTO/ARTBA/AGC Task Force 13 designator that should be used to identify any new or updated Task Force 13 drawings.
- This finding of eligibility is limited to the crashworthiness characteristics of the devices and does not cover their structural features, or conformity with the Manual on Uniform Traffic Control Devices.

- Any changes that may influence the crashworthiness of the device will require a new reimbursement eligibility letter.
- Should the FHWA discover that the qualification testing was flawed, that in-service performance reveals unacceptable safety problems, or that the device being marketed is significantly different from the version that was crash tested, we reserve the right to modify or revoke this letter.
- You will be expected to supply potential users with sufficient information on design and installation requirements to ensure proper performance.
- You will be expected to certify to potential users that the hardware furnished has the same chemistry, mechanical properties, and geometry as that submitted for review, and that it will meet the crashworthiness requirements of the NCHRP Report 350.
- To prevent misunderstanding by others, this letter is designated as number CC-122, and shall not be reproduced except in full. This letter and the test documentation upon which it is based are public information. All such letters and documentation may be reviewed at our office upon request.
- The TREND™ 350 Median is a patented product and considered proprietary. If proprietary devices are specified by highway agency for use on Federal-aid projects, (a) they must be supplied through competitive bidding with equally suitable unpatented items: (b) the highway agency must certify that they are essential for synchronization with the existing highway facilities or that no equally suitable alternative exists: or (c) they must be used for research or for a distinctive type of construction on relatively short sections of road for experimental purposes. Our regulations concerning proprietary products are contained in Title 23, Code of Federal Regulations, Section 635.411.
- This letter shall not be construed as authorization or consent by the FHWA to use, manufacture, or sell any patented device for which the applicant is not the patent holder. The finding of eligibility is limited to the crashworthiness characteristics of the candidate device, and the FHWA is neither prepared nor required to become involved in issues concerning patent law. Patent issues, if any, are to be resolved by the applicant.

Sincerely yours,



Michael S. Griffith
Director, Office of Safety Technologies
Office of Safety

Enclosures

ITEM	DESCRIPTION	QTY.
1	HEAD	1
2	RAIL, 10GA	2
3	RAIL (W/O FIN), 12GA	2
4	RAIL (W/FIN), 12GA	4
5	END RAIL (W/FIN)	2
6	RAIL SPACER ASSEMBLY (POSTS 1 & 2 ONLY)	2
7	RAIL SPACER (ALL POSTS, EXCEPT 1 & 2)	6
8	LINE POST	2
9	SYTP POST	1
10	HBA POST	1
11	ANGLE STRUT	1
12	BEARING PLATE	1
13	SYSTEM CABLE	1

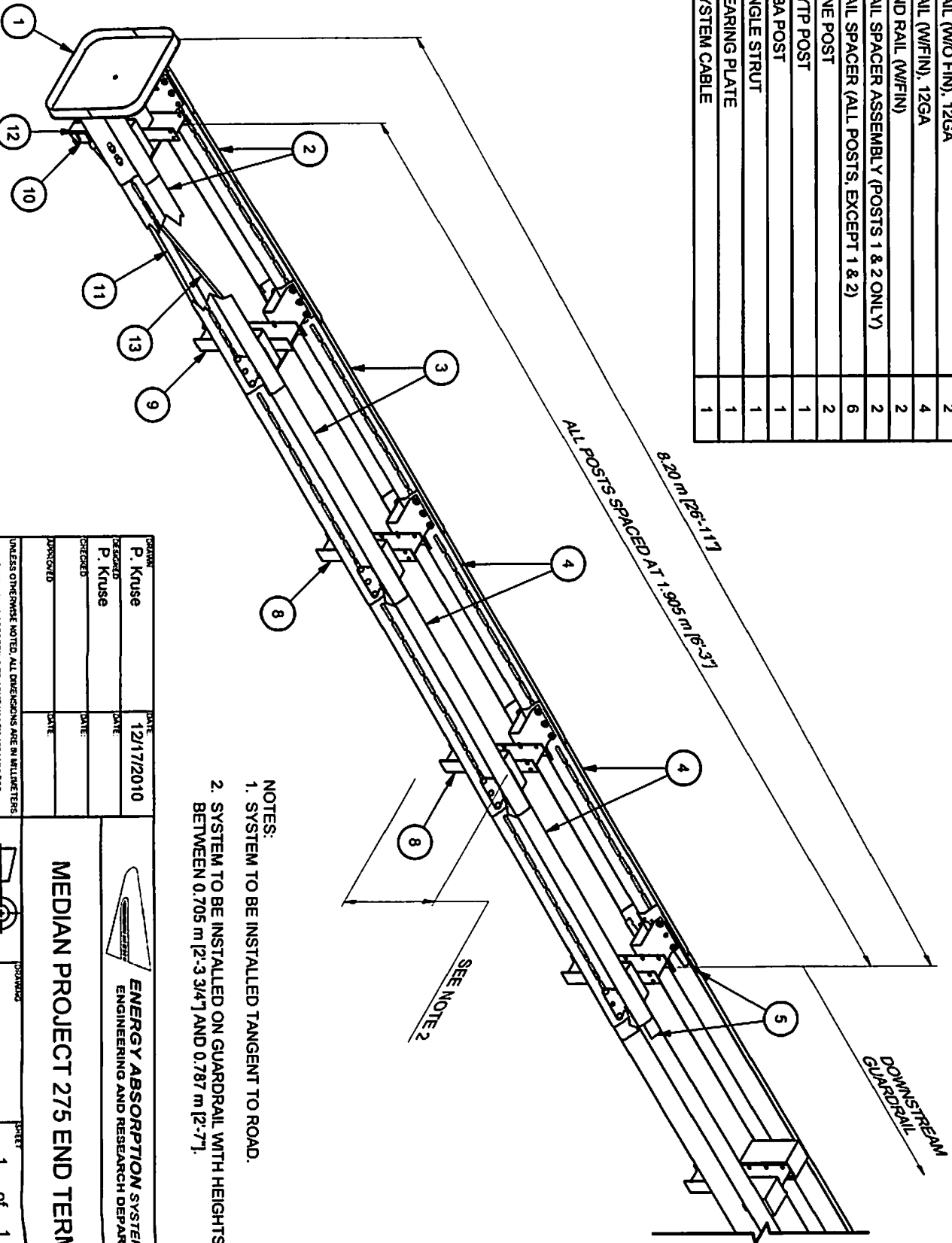

- NOTES:
1. SYSTEM TO BE INSTALLED TANGENT TO ROAD.
 2. SYSTEM TO BE INSTALLED ON GUARDRAIL WITH HEIGHTS BETWEEN 0.705 m (2'-3 3/4") AND 0.787 m (2'-7").

DESIGNED BY P. Kruse	DATE 12/17/2010
CHECKED BY P. Kruse	DATE
APPROVED BY	DATE

UNLESS OTHERWISE NOTED, ALL DIMENSIONS ARE IN MILLIMETERS
DIMENSIONS ACCORDING TO ASME Y14.5M-1994 UNLESS
OTHERWISE SPECIFIED.



ENERGY ABSORPTION SYSTEMS, INC.
ENGINEERING AND RESEARCH DEPARTMENT

MEDIAN PROJECT 275 END TERMINAL



ISSUING

SHEET

1 of 1

REV

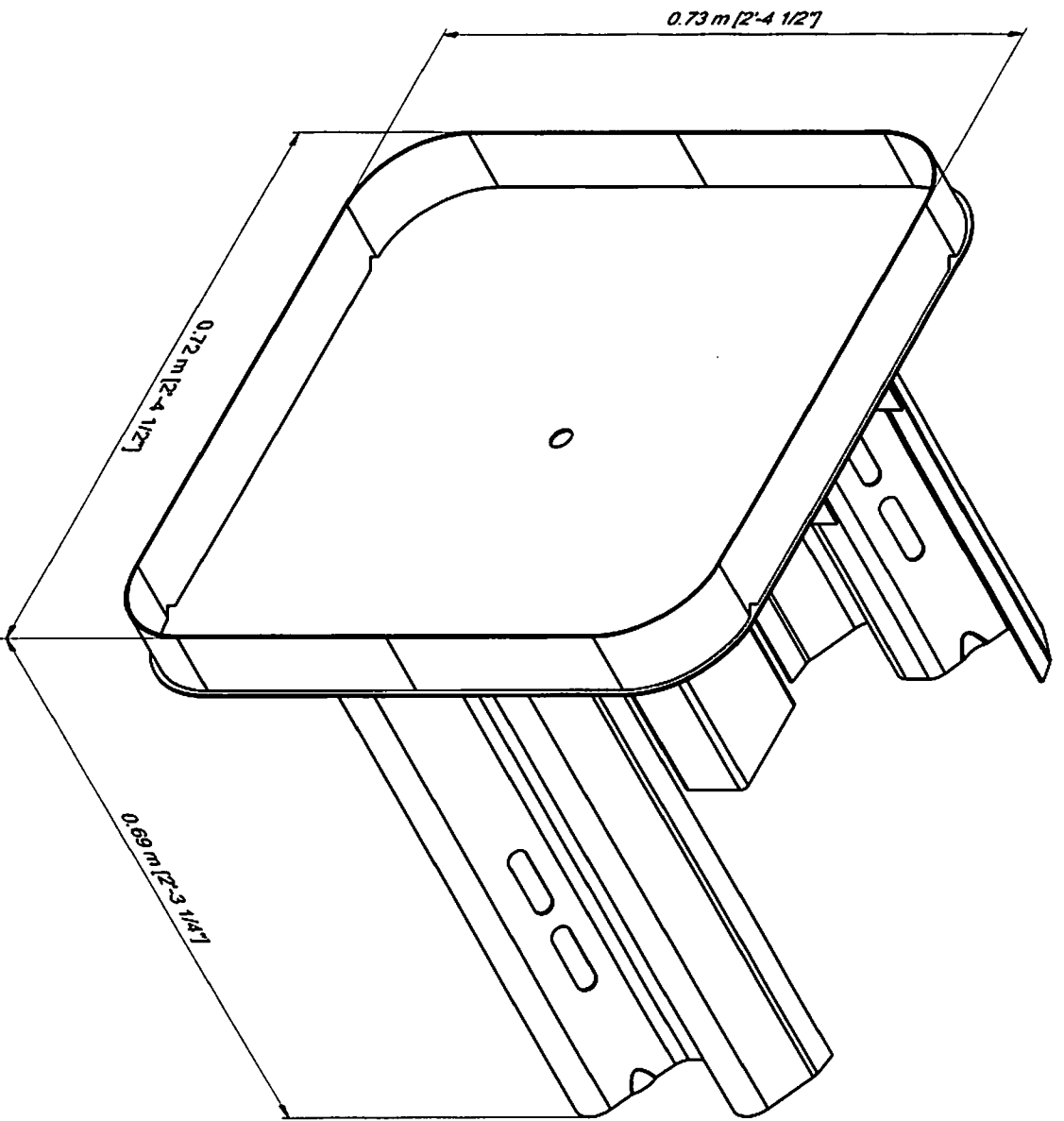

DESIGNED BY	DATE
P. Kruse	12/17/2010
CHECKED BY	DATE
P. Kruse	
APPROVED BY	DATE

UNLESS OTHERWISE NOTED, ALL DIMENSIONS ARE IN MILLIMETERS. DIMENSIONS ACCORDING TO ASME Y14.5M-1994 UNLESS OTHERWISE SPECIFIED.



ENERGY ABSORPTION SYSTEMS, INC.
ENGINEERING AND RESEARCH DEPARTMENT

HEAD



DRAWING

SHEET

1 of 1

REV

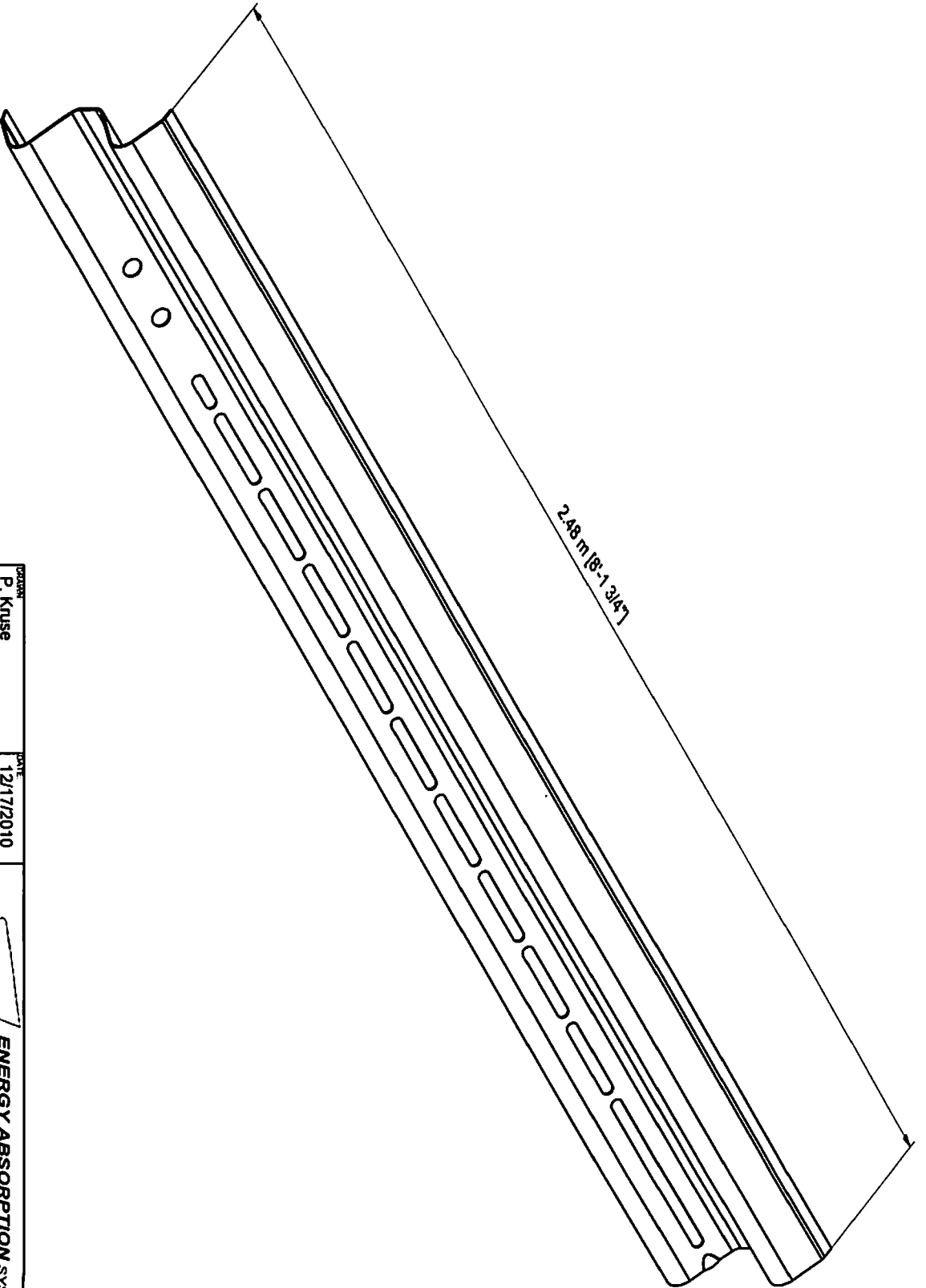

2.48 m (8'-1 3/4")

DESIGNED BY	P. Kruse	DATE	12/17/2010
CHECKED BY	P. Kruse	DATE	
APPROVED BY		DATE	

UNLESS OTHERWISE NOTED, ALL DIMENSIONS ARE IN MILLIMETERS
DIMENSIONS ACCORDING TO ASME Y14.5M-1994 UNLESS
OTHERWISE SPECIFIED



ENERGY ABSORPTION SYSTEMS, INC.
ENGINEERING AND RESEARCH DEPARTMENT

RAIL, 10GA

DATE: 1 of 1

REV: _____

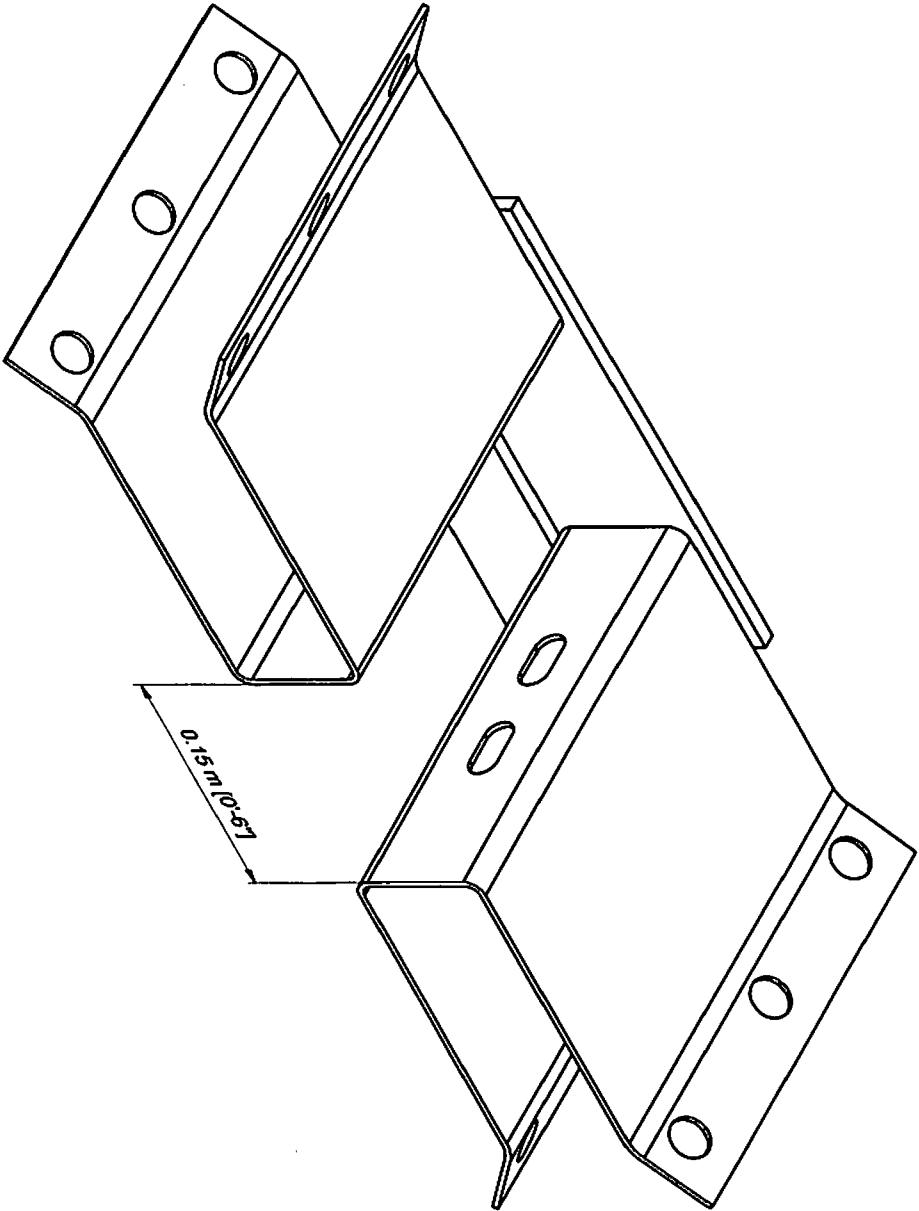

DESIGNER	P. Kruse	DATE	12/17/2010
DESIGNED	P. Kruse	DATE	
CHECKED		DATE	
APPROVED		DATE	

UNLESS OTHERWISE NOTED, ALL DIMENSIONS ARE IN MILLIMETERS
 DIMENSIONS ACCORDING TO ASME Y14.5M-1994 UNLESS
 OTHERWISE SPECIFIED



ENERGY ABSORPTION SYSTEMS, INC.
 ENGINEERING AND RESEARCH DEPARTMENT

**RAIL SPACER ASSEMBLY
 (POSTS 1 & 2 ONLY)**



DRAWING

SHEET
 1 of 1

REV

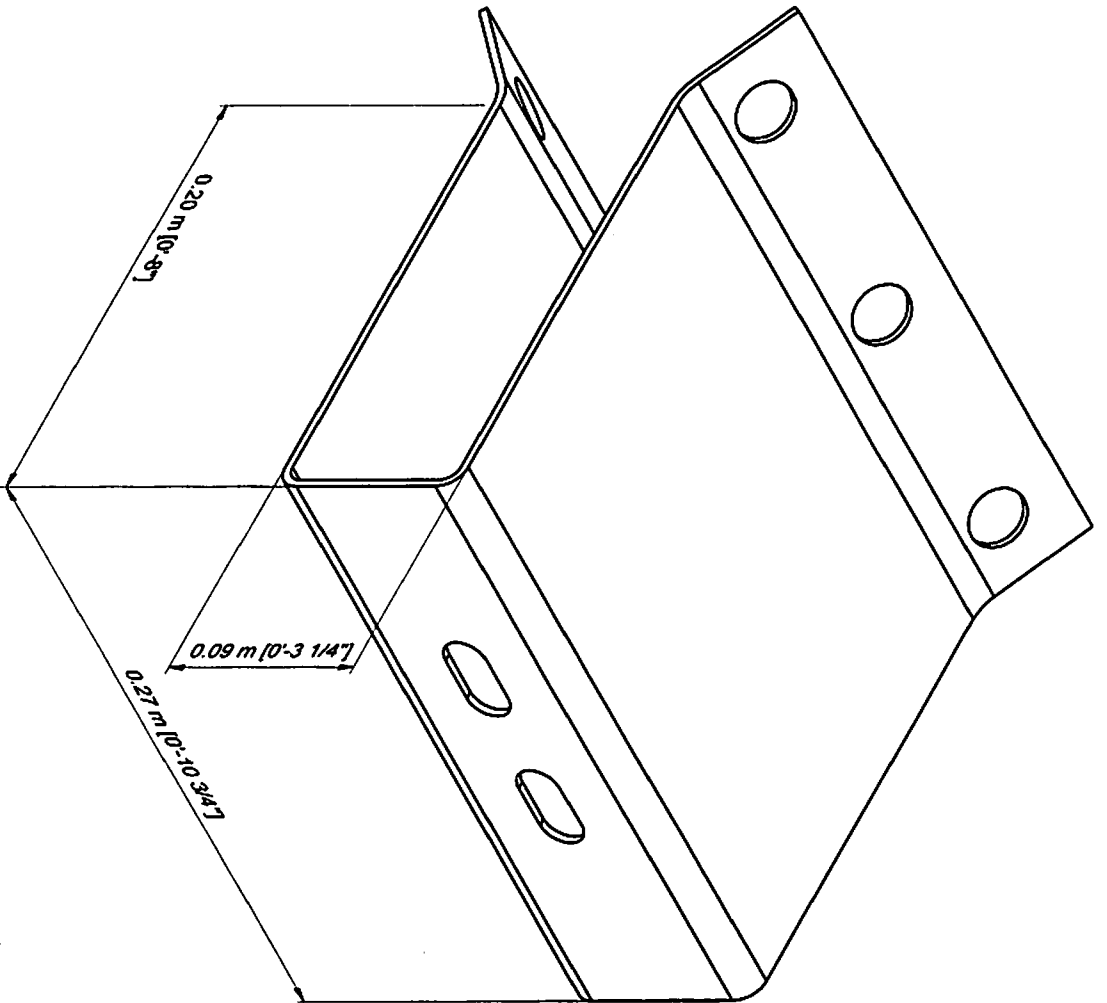

DESIGNED BY P. Kruse	DATE 12/17/2010	 ENERGY ABSORPTION SYSTEMS, INC. ENGINEERING AND RESEARCH DEPARTMENT
CHECKED BY P. Kruse	DATE	
APPROVED BY	DATE	
<small>UNLESS OTHERWISE NOTED, ALL DIMENSIONS ARE IN MILLIMETERS DIMENSIONS ACCORDING TO ASME Y14.5M-1994 UNLESS OTHERWISE SPECIFIED</small>		
RAIL SPACER (ALL POSTS, EXCEPT 1 & 2)		DRAWING NO. 1 OF 1