



U.S. Department
of Transportation

Federal Highway
Administration

November 2, 2018

1200 New Jersey Ave., SE
Washington, D.C. 20590

In Reply Refer To:
HSST-1/CC-147

Mr. Gerrit Dyke, P.E.
Lindsay Transportation Solutions
180 River Road
Rio Vista, CA 94571

Dear Mr. Dyke:

This letter is in response to your September 1, 2018 request for the Federal Highway Administration (FHWA) to review a roadside safety device, hardware, or system for eligibility for reimbursement under the Federal-aid highway program. This FHWA letter of eligibility is assigned FHWA control number CC-147 and is valid until a subsequent letter is issued by FHWA that expressly references this device.

Decision

The following devices are eligible, with details provided in the form which is attached as an integral part of this letter:

- Universal TAU-M Crash Cushion (TAU-M) TL3

Scope of this Letter

To be found eligible for Federal-aid funding, new roadside safety devices should meet the crash test and evaluation criteria contained in the American Association of State Highway and Transportation Officials' Manual for Assessing Safety Hardware (MASH). However, the FHWA, the Department of Transportation, and the United States Government do not regulate the manufacture of roadside safety devices. Eligibility for reimbursement under the Federal-aid highway program does not establish approval, certification or endorsement of the device for any particular purpose or use.

This letter is not a determination by the FHWA, the Department of Transportation, or the United States Government that a vehicle crash involving the device will result in any particular outcome, nor is it a guarantee of the in-service performance of this device. Proper manufacturing, installation, and maintenance are required in order for this device to function as tested.

This finding of eligibility is limited to the crashworthiness of the system and does not cover other structural features, nor conformity with the Manual on Uniform Traffic Control Devices.

Eligibility for Reimbursement

Based solely on a review of crash test results and certifications submitted by the manufacturer, and the crash test laboratory, FHWA agrees that the device described herein meets the crash test and evaluation criteria of the American Association of State Highway and Transportation Officials' Manual for Assessing Safety Hardware (MASH). Therefore, the device is eligible for reimbursement under the Federal-aid highway program if installed under the range of tested conditions.

Name of system: Universal TAU-M Crash Cushion (TAU-M) TL3

Type of system: Redirective, Non-Gating Crash Cushion

Test Level: MASH Test Level 3 (TL3)

Testing conducted by: Safe Technologies, Inc.

Date of request: September 1, 2018

FHWA concurs with the recommendation of the accredited crash testing laboratory as stated within the attached form for systems mounted on concrete only.

Full Description of the Eligible Device

The device and supporting documentation, including reports of the crash tests or other testing done, videos of any crash testing, and/or drawings of the device, are described in the attached form.

Notice

FHWA's determination of continued eligibility for the modified hardware will be based on whether the modified hardware will continue to meet the relevant crash test criteria.

Any user or agency relying on this eligibility letter is expected to use the same designs, specifications, drawings, installation and maintenance instructions as those submitted for review.

You are expected to certify to potential users that the hardware furnished has the same chemistry, mechanical properties, and geometry as that submitted for review, and that it will meet the test and evaluation criteria of the MASH.

Issuance of this letter does not convey property rights of any sort or any exclusive privilege. This letter is based on the premise that information and reports submitted by you are accurate and correct. We reserve the right to modify or revoke this letter if: (1) there are any inaccuracies in the information submitted in support of your request for this letter, (2) the qualification testing was flawed, (3) in-service performance or other information reveals safety problems, (4) the system is significantly different from the version that was crash tested, or (5) any other information indicates that the letter was issued in error or otherwise does not reflect full and complete information about the crashworthiness of the system.

Standard Provisions

- To prevent misunderstanding by others, this letter of eligibility designated as FHWA control number CC-147 shall not be reproduced except in full. This letter and the test documentation upon which it is based are public information. All such letters and documentation may be

reviewed upon request.

- This letter shall not be construed as authorization or consent by the FHWA to use, manufacture, or sell any patented system for which the applicant is not the patent holder.
- If the subject device is a patented product it may be considered to be proprietary. If proprietary systems are specified by a highway agency for use on Federal-aid projects: (a) they must be supplied through competitive bidding with equally suitable unpatented items; (b) the highway agency must certify that they are essential for synchronization with the existing highway facilities or that no equally suitable alternative exists; or (c) they must be used for research or for a distinctive type of construction on relatively short sections of road for experimental purposes. Our regulations concerning proprietary products are contained in Title 23, Code of Federal Regulations, Section 635.411.

Sincerely yours,

A handwritten signature in blue ink that reads "Michael S. Griffith". The signature is written in a cursive style.

Michael S. Griffith
Director, Office of Safety Technologies
Office of Safety

Enclosures

Request for Federal Aid Reimbursement Eligibility of Highway Safety Hardware

Submitter	Date of Request:	August 31, 2018	<input checked="" type="radio"/> New <input type="radio"/> Resubmission
	Name:	Gerrit A. Dyke, P.E.	
	Company:	Lindsay Transportation Solutions, Inc.	
	Address:	180 River Road, Rio Vista, CA 94571	
	Country:	USA	
	To:	Michael S. Griffith, Director FHWA, Office of Safety Technologies	

I request the following devices be considered eligible for reimbursement under the Federal-aid highway program.

Device & Testing Criterion - Enter from right to left starting with Test Level

!-!-!

System Type	Submission Type	Device Name / Variant	Testing Criterion	Test Level
'CC': Crash Cushions, Attenuators, & Terminals	<input checked="" type="radio"/> Physical Crash Testing <input type="radio"/> Engineering Analysis	Universal TAU-M Crash Cushion (TAU-M)	AASHTO MASH	TL3

By submitting this request for review and evaluation by the Federal Highway Administration, I certify that the product(s) was (were) tested in conformity with the AASHTO Manual for Assessing Safety Hardware and that the evaluation results meet the appropriate evaluation criteria in the MASH.

Individual or Organization responsible for the product:

Contact Name:	Gerrit A. Dyke, P.E.	Same as Submitter <input checked="" type="checkbox"/>
Company Name:	Lindsay Transportation Solutions, Inc.	Same as Submitter <input checked="" type="checkbox"/>
Address:	180 River Road, Rio Vista, CA 94571	Same as Submitter <input checked="" type="checkbox"/>
Country:	USA	Same as Submitter <input checked="" type="checkbox"/>

Enter below all disclosures of financial interests as required by the FHWA 'Federal-Aid Reimbursement Eligibility Process for Safety Hardware Devices' document.

Safe Technologies, Inc. (STI) performs testing and analysis services for Lindsay Transportation Solutions, Inc. (LTS). STI is a wholly owned subsidiary of LTS. STI is a fully accredited crash test facility to ISO 17025 by A2LA and is recognized by the US Federal Highway Administration (FHWA) to perform full scale crash tests per NCHRP Report 350 and MASH criteria.

The STI laboratory manager, technicians, and laborers are compensated by LTS for salaries and wages. STI and staff does not receive any incentives, compensation, commissions, or professional fees corresponding to the outcome of any testing or analysis.

STI or staff does not receive any research funding or other research support from LTS. STI and staff also do not have any financial interest in patents, copyrights, or other intellectual property associated with the products they test or analyze.

KARCO Engineering, LLC. was contracted by LTS to collaborate with STI for this testing program. KARCO provided guidance, recommendations, and suggestions for testing and reporting practices. KARCO reviewed test data and reports to ensure accuracy and correct representation of test parameters and results. KARCO nor any KARCO employee has any financial interest in LTS, STI, or the product being tested.

PRODUCT DESCRIPTION

- New Hardware or Significant Modification
 Modification to Existing Hardware

The Universal TAU-M™ Parallel (TAU-M) is a redirective, non-gating crash cushion designed to meet the latest test standards defined in the Manual for Assessing Safety Hardware (MASH), Second Edition, 2016. The TAU-M system utilizes a cable anchoring system, telescoping thrie-beam panels, and energy absorbing cartridges (EAC) to absorb kinetic energy and safely contain or redirect impacting vehicles. The system is comprised of EACs, cables, a front cable anchor, a backstop, four end panel mounts, middle support assemblies (midsupports), cable guides, a front support, a front support leg kit, sliding panels, two end panels, slider kits, slider shims, a tether kit, four tow hooks, and a delineation bracket. The system has a nominal 32 5/8" height and 34 1/2" width. The test level 3 system measures approximately 287" (7 Bays) in length.

TAU-M has anchorage configurations for Concrete or Asphalt foundations or existing roadways. For Asphalt applications, additional nested slider panels are utilized on the rear 2 bays for Test Level 3.

TAU-M may be configured in part using some components of the TAU-II (NCHRP 350) system including the Compact Backstop and cable assemblies from the Wide TAU-II. Details of the conversion kit and component substitutions are in Enclosure A.

TAU-M utilizes standard corrugated thrie beam panels which enable the application of standard transition methods to various roadside hardware and barrier systems. Enclosure A details several standard transitions using AASHTO thrie beam panels and components. A proprietary transition using nested angled and standard end panels was tested and is available.

Any delineation pattern, tape, or decal may be placed on the Delineation Bracket attached to the TAU-M. In addition, variations of brackets may be utilized with the TAU-M. Reference Enclosure A.

TAU-M may display identification decals, tags, or stamps for product identification, component tracking and quality control. The identification method and location shall not effect the capacity, function, or performance of the TAU-M. Reference Enclosure A.

The TAU-M may be painted, stained, or powder coated on surfaces that do not effect the function of the system in place of or in addition to galvanizing. Reference Enclosure A for details regarding surfaces that may be coated and the components or surfaces that may not.

An alternative nut for the slider bolts may be used which limits the rotation of the nut during assembly and disassembly. The alternative nut does not effect the capacity of the joint, or the function or performance of the system. Details of the alternative nut are in Enclosure A.

The EACs used on the TAU-M have embossed lettering on their surfaces. The lettering may be changed and updated as required without effecting the function or performance of the component or system.

Manufacturing drawings may be adjusted to ensure manufacturing capability and consistency with MASH tested and certified product.

CRASH TESTING

By signature below, the Engineer affiliated with the testing laboratory, agrees in support of this submission that all of the critical and relevant crash tests for this device listed above were conducted to meet the MASH test criteria. The Engineer has determined that no other crash tests are necessary to determine the device meets the MASH criteria.

Engineer Name:	Joseph Nagy	
Engineer Signature:	Joseph Nagy	Digitally signed by Joseph Nagy Date: 2018.08.31 15:55:40 -07'00'
Address:	170 River Road, Rio Vista, CA 94571	Same as Submitter <input type="checkbox"/>
Country:	USA	Same as Submitter <input type="checkbox"/>

A brief description of each crash test and its result:

Required Test Number	Narrative Description	Evaluation Results
3-30 (1100C)	<p>The TAU-M was determined to have successfully met all of the evaluation criteria for MASH Test 3-30 for non-gating crash cushions.</p> <p>The TAU-M crash cushion satisfied the MASH structural adequacy criteria for its intended function as a non-gating crash cushion. The test article captured the 1100C vehicle in a controlled manner. The vehicle did not penetrate, underide, or override the installation. The test article exhibited controlled permanent and dynamic deflection in the test.</p> <p>All of the occupant risk criteria were satisfied in testing the TAU-M crash cushion. Theoretical OIVs in the longitudinal and lateral directions were below the limit of 40.0 ft/s (12.2 m/s). ORAs in the longitudinal and lateral directions were below the limit of 20.49 G. There was no test article debris detached during the test.</p> <p>There was minimal deformation to the occupant compartment of the 1100C test vehicle. There was no intrusion into the occupant compartment. The test vehicle remained upright during and after the collision with moderate roll and minor pitch.</p> <p>The TAU-M crash cushion was judged as satisfying the applicable MASH vehicle trajectory criteria.</p>	PASS

Required Test Number	Narrative Description	Evaluation Results
3-31 (2270P)	<p>Test 3-31 was performed on both Concrete and Asphalt configurations:</p> <p>In each test, the TAU-M was determined to have successfully met all of the evaluation criteria for MASH Test 3-31 for non-gating crash cushions in both the Concrete and Asphalt configurations.</p> <p>In each test, the TAU-M crash cushion satisfied the MASH structural adequacy criteria for its intended function as a non-gating crash cushion. The test article captured the 2270P vehicle in a controlled manner. The vehicle did not penetrate, underride or override the installation. The test article exhibited controlled permanent and dynamic deflection in each test.</p> <p>All of the occupant risk criteria were satisfied in testing the TAU-M crash cushion. Theoretical OIVs in the longitudinal and lateral directions were below the preferred limit of 30.0 ft/s (9.1 m/s). ORAs in the longitudinal and lateral directions were below the limit of 20.49 G. In the Asphalt configuration, the ORAs in the longitudinal and lateral directions were below the preferred limit of 15.0 G. There was no test article debris detached during the test.</p> <p>In each test, there was no deformation in the occupant compartment of the 2270P test vehicle. There was no intrusion into the occupant compartment. The test vehicle remained upright during and after the collision with minor roll and pitch.</p> <p>The TAU-M crash cushion was judged as satisfying the applicable MASH vehicle trajectory criteria for both Concrete and Asphalt configurations.</p>	PASS

3-32 (1100C)	<p>The TAU-M was determined to have successfully met all of the evaluation criteria for MASH Test 3-32 for non-gating crash cushions.</p> <p>The TAU-M crash cushion satisfied the MASH structural adequacy criteria for its intended function as a non-gating crash cushion. The test article captured the 1100C vehicle in a controlled manner. The vehicle did not penetrate, underride or override the installation. The test article exhibited controlled permanent and dynamic deflection in the test.</p> <p>All of the occupant risk criteria were satisfied in testing the TAU-M crash cushion. Theoretical OIVs in the longitudinal and lateral directions were at or below the limit of 40.0 ft/s (12.2 m/s). ORAs in the longitudinal and lateral directions were below the preferred limit of 15.0 G. There was no test article debris detached during the test.</p> <p>There was minimal deformation in the occupant compartment of the 1100C test vehicle. There was no intrusion into the occupant compartment. The test vehicle remained upright during and after the collision with minor roll and moderate pitch.</p> <p>The TAU-M crash cushion was judged as satisfying the applicable MASH vehicle trajectory criteria.</p>	PASS
--------------	---	------

3-33 (2270P)	<p>The TAU-M was determined to have successfully met all of the evaluation criteria for MASH Test 3-33 for non-gating crash cushions.</p> <p>The TAU-M crash cushion satisfied the MASH structural adequacy criteria for its intended function as a non-gating crash cushion. The test article captured the 2270P vehicle in a controlled manner. The vehicle did not penetrate, underide, or override the installation. The test article exhibited controlled permanent and dynamic deflection in the test.</p> <p>All of the occupant risk criteria were satisfied in testing the TAU-M crash cushion. Theoretical OIVs in the longitudinal and lateral directions were at or below the preferred limit of 30 ft/s (9.1 m/s). ORAs in the longitudinal and lateral directions were below the limit of 20.49 G. There was no test article debris detached during the test.</p> <p>There was minimal deformation in the occupant compartment of the 2270P test vehicle. There was no intrusion into the occupant compartment. The test vehicle remained upright during and after the collision with minor roll and pitch.</p> <p>The TAU-M crash cushion was judged as satisfying the applicable MASH vehicle trajectory criteria.</p>	PASS
--------------	--	------

3-34 (1100C)	<p>The TAU-M was determined to have successfully met all of the evaluation criteria for MASH Test 3-34 for non-gating crash cushions.</p> <p>The TAU-M crash cushion satisfied the MASH structural adequacy criteria for its intended function as a non-gating crash cushion. The test article first captured and later redirected the 1100C vehicle in a controlled manner. The vehicle did not penetrate, underride, or override the installation. The test article exhibited some permanent and dynamic deflection in the test.</p> <p>All of the occupant risk criteria were satisfied in testing the TAU-M crash cushion. Theoretical OIVs in the longitudinal and lateral directions were well below the preferred limit of 30.0 ft/s (9.1 m/s). ORAs in the longitudinal and lateral directions were below the preferred limit of 15.0 G. There was no test article debris detached during the test.</p> <p>There was minimal deformation to the occupant compartment of the 1100C test vehicle. There was no intrusion into the occupant compartment. The test vehicle remained upright during and after the collision with minor roll and pitch.</p> <p>The TAU-M crash cushion was judged as satisfying the applicable MASH vehicle trajectory criteria.</p>	PASS
--------------	--	------

3-35 (2270P)	<p>The TAU-M was determined to have successfully met all of the evaluation criteria for MASH Test 3-35 for non-gating crash cushions.</p> <p>The TAU-M crash cushion satisfied the MASH structural adequacy criteria for its intended function as a non-gating crash cushion. The test article first captured and later redirected the 2270P vehicle in a controlled manner. The vehicle did not penetrate, underride, or override the installation. The test article exhibited controlled permanent and dynamic deflection in the test.</p> <p>All of the occupant risk criteria were satisfied in testing the TAU-M crash cushion. Theoretical OIVs in the longitudinal and lateral directions were well below the preferred limit of 30.0 ft/s (9.1 m/s). ORAs in the longitudinal and lateral directions were below the preferred limit of 15.0 G. There was no test article debris detached during the test.</p> <p>There was minimal deformation to the occupant compartment of the 2270P test vehicle. There was no intrusion into the occupant compartment. The test vehicle remained upright during and after the collision with moderate roll and minor pitch.</p> <p>The TAU-M crash cushion was judged as satisfying the applicable MASH vehicle trajectory criteria.</p>	PASS
--------------	---	------

3-36 (2270P)	<p>Test 3-36 was performed on both Concrete and Asphalt configurations:</p> <p>In each configuration, the TAU-M was determined to have successfully met all of the evaluation criteria for MASH Test 3-36 for non-gating crash cushions.</p> <p>In each configuration, the TAU-M crash cushion satisfied the MASH structural adequacy criteria for its intended function as a non-gating crash cushion. The test article first captured and later redirected the 2270P vehicle in a controlled manner. The vehicle did not penetrate, underide, or override the installation. The test article exhibited controlled permanent and dynamic deflection in each test.</p> <p>In each configuration, all of the occupant risk criteria were satisfied in testing the TAU-M crash cushion. Theoretical OIVs in the longitudinal and lateral directions were below the preferred limit of 30.0 ft/s (9.1 m/s). ORAs in the longitudinal and lateral directions were below or at the preferred limit of 15.0 G. There was no test article debris detached during the test.</p> <p>In each configuration, there was moderate deformation to the occupant compartment of the 2270P test vehicle. There was no intrusion into the occupant compartment. The test vehicle remained upright during and after the collision with moderate roll and minor pitch.</p> <p>The TAU-M crash cushion was judged as satisfying the applicable MASH vehicle trajectory criteria for both Concrete and Asphalt configurations.</p>	PASS
--------------	--	------

3-37 (2270P)	<p>The TAU-M was determined to have successfully met all of the evaluation criteria for MASH Test 3-37a for non-gating crash cushions.</p> <p>The TAU-M crash cushion satisfied the MASH structural adequacy criteria for its intended function as a non-gating crash cushion. The test article first captured and later redirected the 2270P vehicle in a controlled manner. The vehicle did not penetrate, underide, or override the installation. The test article exhibited controlled permanent and dynamic deflection in the test.</p> <p>All of the occupant risk criteria were satisfied in testing the TAU-M crash cushion. Theoretical OIVs in the longitudinal and lateral directions were below the limit of 40.0 ft/s (12.2 m/s). ORAs in the longitudinal and lateral directions were below the limit of 20.49 G. There were some detached fragments of a blockout that landed in the near vicinity of the backstop, which did not pose a threat to the occupant compartment, other vehicles, pedestrians or personnel in a work zone.</p> <p>There was moderate deformation to the occupant compartment of the 2270P test vehicle. There was no intrusion into the occupant compartment. The test vehicle remained upright during and after the collision with moderate roll and minor pitch.</p> <p>The TAU-M crash cushion was judged as satisfying the applicable MASH vehicle trajectory criteria.</p>	PASS
3-38 (1500A)	Calculations performed to demonstrate acceptable occupant risk values per MASH evaluation criteria. Reference Enclosure A, "TAU-M Crash Cushion System MASH Configuration Justification" section titled "1500A Vehicle (MASH Test 3-38)".	PASS
3-40 (1100C)		Non-Relevant Test, not conducted
3-41 (2270P)		Non-Relevant Test, not conducted
3-42 (1100C)		Non-Relevant Test, not conducted
3-43 (2270P)		Non-Relevant Test, not conducted
3-44 (2270P)		Non-Relevant Test, not conducted
3-45 (1500A)		Non-Relevant Test, not conducted

Full Scale Crash Testing was done in compliance with MASH by the following accredited crash test laboratory (cite the laboratory's accreditation status as noted in the crash test reports.):

Laboratory Name:	Safe Technologies Inc.	
Laboratory Signature:	Joseph Nagy	Digitally signed by Joseph Nagy Date: 2018.08.31 16:09:30 -07'00'
Address:	170 River Road, Rio Vista, CA 94571	Same as Submitter <input type="checkbox"/>
Country:	USA	Same as Submitter <input type="checkbox"/>
Accreditation Certificate Number and Dates of current Accreditation period :	A2LA 1851.01 Valid to March 31, 2020	

Submitter Signature*: **Gerrit Dyke** Digitally signed by Gerrit Dyke
Date: 2018.08.31 16:13:19 -07'00'

Submit Form

ATTACHMENTS

Attach to this form:

- 1) Additional disclosures of related financial interest as indicated above.
- 2) A copy of the full test report, video, and a Test Data Summary Sheet for each test conducted in support of this request.
- 3) A drawing or drawings of the device(s) that conform to the Task Force-13 Drawing Specifications [[Hardware Guide Drawing Standards](#)]. For proprietary products, a single isometric line drawing is usually acceptable to illustrate the product, with detailed specifications, intended use, and contact information provided on the reverse. Additional drawings (not in TF-13 format) showing details that are relevant to understanding the dimensions and performance of the device should also be submitted to facilitate our review.

FHWA Official Business Only:

Eligibility Letter		Key Words
Number	Date	



t = 0.000 sec

t = 0.050 sec

t = 0.100 sec

t = 0.150 sec

t = 0.250 sec

t = 0.350 sec

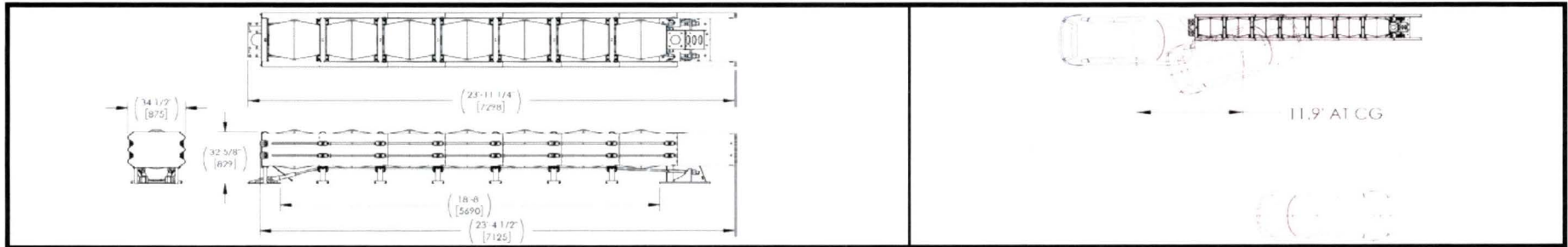

General Information

Test Agency..... **SAFE TECHNOLOGIES, INC.**
 Test Number..... TAU330-C1
 Test Designation MASH 3-30
 Date..... 1/2/2018

Test Article

Name Universal TAU-M, TL-3
 Type Redirective, Non-gating Crash Cushion
 Installation Length 287 1/4 in (7.30 m)
 Width 34 1/2 in (875 mm)
 Height 32 5/8 in (829 mm)

Test Vehicle

Type / Designation 1100C
 Make and Model 2011 Hyundai Accent
 Curb Weight 2,460 lb (1,116 kg)
 Test Inertial Weight 2,427 lb (1,101 kg)
 Gross Static Weight 2,593 lb (1,176 kg)

Impact Conditions

Speed 61.8 mph (99.5 km/h)
 Angle 0.0 deg
 Location / Orientation 1/4 Offset

Exit Conditions

Speed..... N/A
 Angle..... N/A

Post Impact Trajectory

Vehicle Stability Satisfactory
 Longitudinal Stopping Distance (CG) 11.9 ft (3.62 m)
 Vehicle Snagging/Pocketing N/A

Occupant risk Values

Longitudinal OIV 38.1 ft/s (11.6 m/s)
 Lateral OIV 1.64 ft/s (0.5 m/s)
 Longitudinal ORA 17.7 G
 Lateral ORA 4.8 G
 THIV 38.4 ft/s (11.7 m/s)
 PHD 17.8 G
 ASI 1.27

Test Article Damage:..... Minimal

Test Article Deflection

Longitudinal system stroke..... 8.05 ft (2.45 m)
 Permanent lateral deflection 6.0 in (15.2 cm)
 Dynamic lateral deflection 16.9 in (42.9 cm)

Vehicle Damage

VDS..... 12-FL-5
 CDC..... 12FLEW3
 Maximum Interior Deformation 0.38 in (9.53 mm) in the dashboa

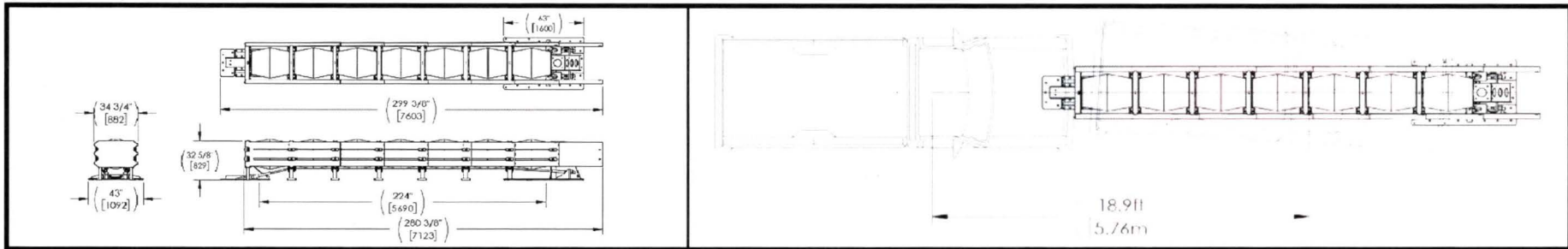
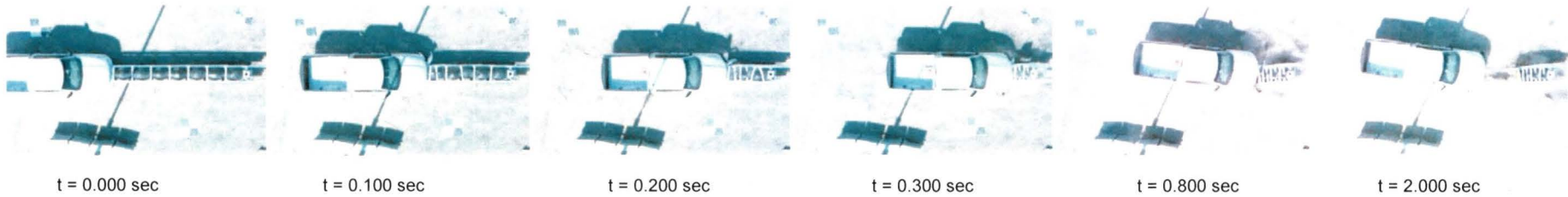

General Information

Test Agency..... **SAFE TECHNOLOGIES, INC.**
 Test Number..... TAU331A-C1
 Test Designation MASH 3-31
 Date..... 7/26/2018

Test Article

Name Universal TAU-M, TL-3
 Type Redirective, Non-gating Crash Cushion
 Installation Length 299 3/8 in (7.60 m)
 Width 43 in (1.09 m)
 Height 32 5/8 in (829 mm)

Test Vehicle

Type / Designation 2270P
 Make and Model 2012 Dodge Ram 1500
 Curb Weight 4,917 lb (2,230.5 kg)
 Test Inertial Weight 5,025 lb (2,279.5 kg)
 Gross Static Weight 5,025 lb (2,279.5 kg)

Impact Conditions

Speed 62.5 mph (100.6 km/h)
 Angle 0.0 deg
 Location / Orientation Front/Center

Exit Conditions

Speed..... N/A
 Angle..... N/A

Post Impact Trajectory

Vehicle Stability Satisfactory
 Longitudinal Stopping Distance (CG) 18.9 ft (5.76 m)
 Vehicle Snagging/Pocketing N/A

Occupant risk Values

Longitudinal OIV 28.5 ft/s (8.7 m/s)
 Lateral OIV 0.7 ft/s (0.2 m/s)
 Longitudinal ORA 13.8 G
 Lateral ORA 2.4 G
 THIV 28.5 ft/s (8.7 m/s)
 PHD 13.9 G
 ASI 1.06

Test Article Damage:..... Minimal

Test Article Deflection

Longitudinal System Stroke..... 15.0 ft (4.57 m)
 Permanent Lateral Deflection 5.2 in (13.2 cm)
 Dynamic Lateral Deflection 6.2 in (15.7 cm)

Vehicle Damage

VDS..... 12-FC-4
 CDC..... 12FDEW1
 Maximum Interior Deformation No Deformation

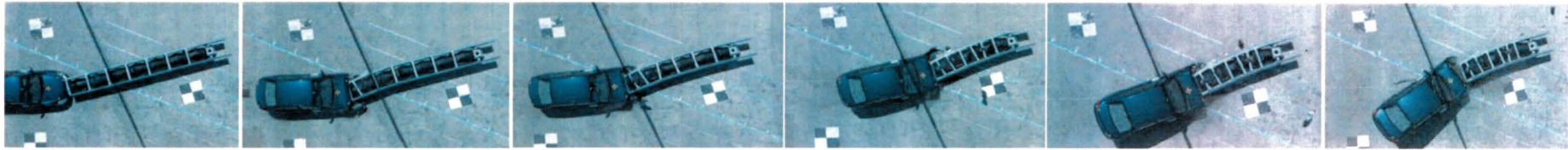

t = 0.000 sec

t = 0.050 sec

t = 0.100 sec

t = 0.200 sec

t = 0.300 sec

t = 0.500 sec

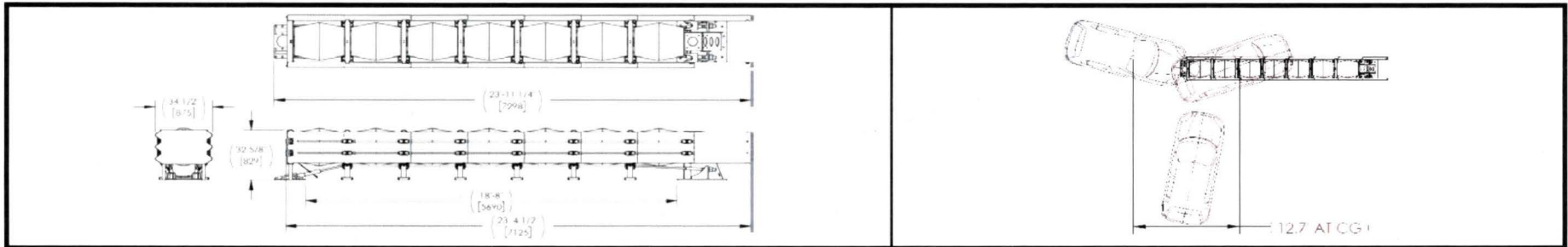

General Information

Test Agency..... **SAFE TECHNOLOGIES, INC.**
 Test Number..... TAU332-C2
 Test Designation MASH 3-32
 Date..... 4/26/2018

Test Article

Name Universal TAU-M, TL-3
 Type Redirective, Non-gating Crash Cushion
 Installation Length 287 1/4 in (7.30 m)
 Width 34 1/2 in (875 mm)
 Height 32 5/8 in (829 mm)

Test Vehicle

Type / Designation 1100C
 Make and Model 2011 Hyundai Accent
 Curb Weight 2,434 lb (1,104 kg)
 Test Inertial Weight 2,447 lb (1,110 kg)
 Gross Static Weight 2,615 lb (1,186 kg)

Impact Conditions

Speed 62.6 mph (100.8 km/h)
 Angle 15 deg
 Location / Orientation Front/Center

Exit Conditions

Speed..... N/A
 Angle..... N/A

Post Impact Trajectory

Vehicle Stability Satisfactory
 Longitudinal Stopping Distance (CG) 12.7 ft (3.87 m)
 Vehicle Snagging/Pocketing N/A

Occupant risk Values

Longitudinal OIV 40.0 ft/s (12.2 m/s)
 Lateral OIV 3.61 ft/s (1.1 m/s)
 Longitudinal ORA 11.8 G
 Lateral ORA 3.1 G
 THIV 40.7 ft/s (12.4 m/s)
 PHD 12.1 G
 ASI 1.37

Test Article Damage:..... Minimal

Test Article Deflection

Longitudinal system stroke..... 10.2 ft (3.10 m)
 Permanent lateral deflection 10.8 in (27.4 cm)
 Dynamic lateral deflection 17.9 in (45.4 cm)

Vehicle Damage

VDS..... 12-FC-4
 CDC..... 12FDEW2
 Maximum Interior Deformation 0.06 in (1.59 mm) in the driver

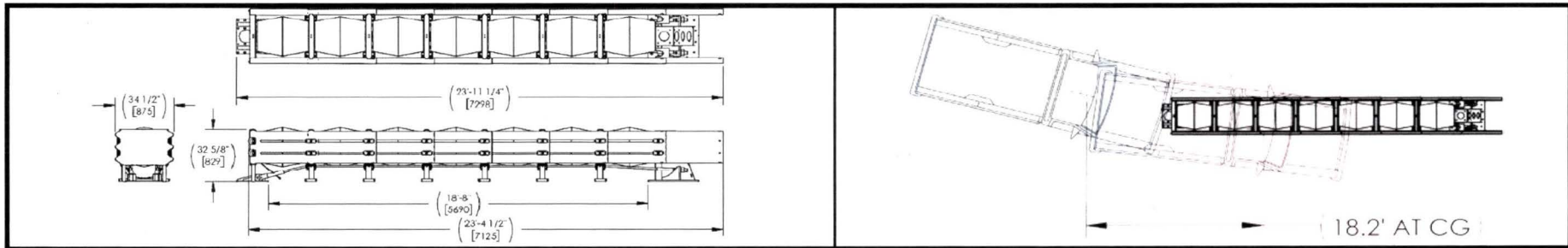
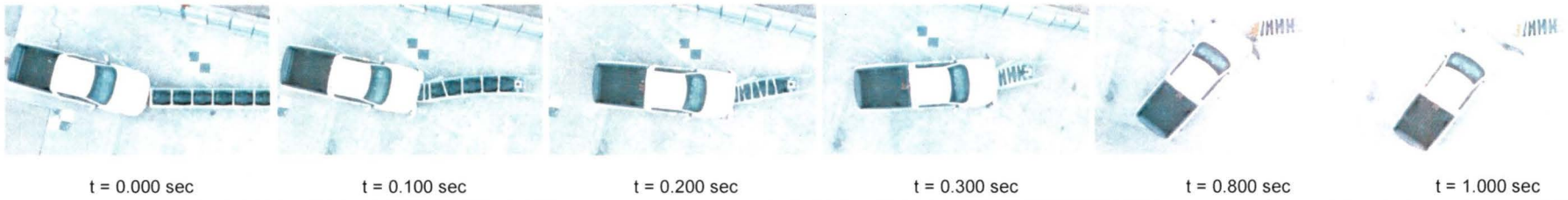

General Information

Test Agency..... **SAFE TECHNOLOGIES, INC.**
 Test Number..... TAU333-C1
 Test Designation MASH 3-33
 Date..... 5/25/2018

Test Article

Name Universal TAU-M, TL-3
 Type Redirective, Non-gating Crash Cushion
 Installation Length 287 1/4 in (7.30 m)
 Width 34 1/2 in (875 mm)
 Height 32 5/8 in (829 mm)

Test Vehicle

Type / Designation 2270P
 Make and Model 2012 Dodge Ram 1500
 Curb Weight 5,027 lb (2,280 kg)
 Test Inertial Weight 4,984 lb (2,260.5 kg)
 Gross Static Weight 4,984 lb (2,260.5 kg)

Impact Conditions

Speed 62.6 mph (100.8 km/h)
 Angle 15 deg
 Location / Orientation Front/Center

Exit Conditions

Speed..... N/A
 Angle..... N/A

Post Impact Trajectory

Vehicle Stability Satisfactory
 Longitudinal Stopping Distance (CG) 18.2 ft (5.53 m)
 Vehicle Snagging/Pocketing N/A

Occupant risk Values

Longitudinal OIV 29.9 ft/s (9.1 m/s)
 Lateral OIV 2.30 ft/s (0.7 m/s)
 Longitudinal ORA 15.3 G
 Lateral ORA 2.9 G
 THIV 30.2 ft/s (9.2 m/s)
 PHD 15.4 G
 ASI 1.04

Test Article Damage:..... Minimal

Test Article Deflection

Longitudinal System Stroke..... 15.3 ft (4.7 m)
 Permanent Lateral Deflection 7.3 in (18.6 cm)
 Dynamic Lateral Deflection 17.7 in (45.0 cm)

Vehicle Damage

VDS..... 12-FC-3
 CDC..... 12FCEW1
 Maximum Interior Deformation 0.56 in (14.3 mm) on left

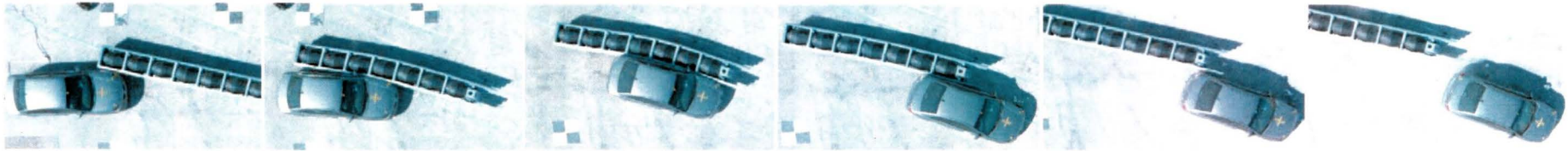

t = 0.000 sec

t = 0.100 sec

t = 0.200 sec

t = 0.300 sec

t = 0.350 sec

t = 0.400 sec

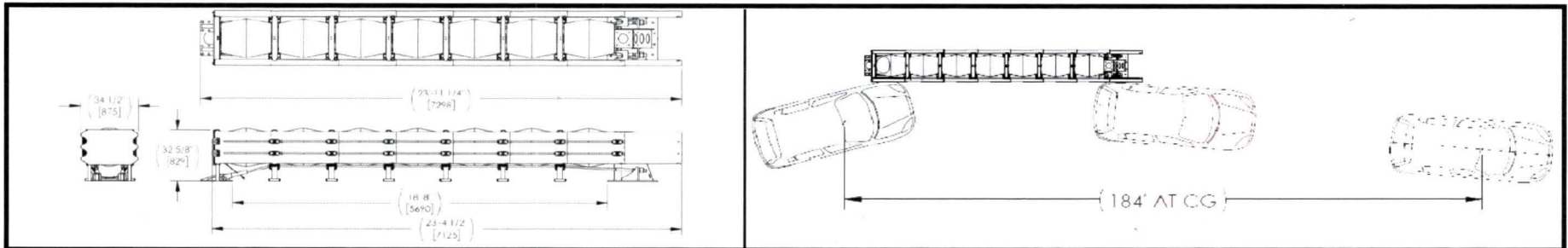

General Information

Test Agency..... **SAFE TECHNOLOGIES, INC.**
 Test Number..... TAU334-C1
 Test Designation MASH 3-34
 Date..... 5/4/2018

Test Article

Name Universal TAU-M, TL-3
 Type Redirective, Non-gating Crash Cushion
 Installation Length 287 1/4 in (7.30 m)
 Width 34 1/2 in (875 mm)
 Height 32 5/8 in (829 mm)

Test Vehicle

Type / Designation 1100C
 Make and Model 2011 Kia Rio
 Curb Weight 2,462 lb (1,116.5 kg)
 Test Inertial Weight 2,454 lb (1,113 kg)
 Gross Static Weight 2,619 lb (1,188 kg)

Impact Conditions

Speed 62.9 mph (101.3 km/h)
 Angle 15.0 deg
 Location / Orientation CIP, 2.5 ft (76.4 cm) downstream from upstream end

Exit Conditions

Speed..... 57 mph (92.4 km/h)
 Angle..... 20 deg

Post Impact Trajectory

Vehicle Stability Satisfactory
 Longitudinal Stopping Distance (CG) 184 ft (56.1 m)
 Vehicle Snagging/Pocketing None

Occupant risk Values

Longitudinal OIV 6.6 ft/s (2.0 m/s)
 Lateral OIV 16.1 ft/s (4.9 m/s)
 Longitudinal ORA 3.7 G
 Lateral ORA 10.5 G
 THIV 17.7 ft/s (5.4 m/s)
 PHD 10.6 G
 ASI 0.82

Test Article Damage:..... Minimal Cosmetic Damage

Test Article Deflection

Longitudinal System Stroke..... N/A
 Permanent Lateral Deflection 1.6 in (3.9 cm)
 Dynamic Lateral Deflection 10.1 in (25.5 cm)

Vehicle Damage

VDS..... 11-FL-3
 CDC..... 11FDAW2
 Maximum Interior Deformation 0.38 in (9.53 mm), floor pan

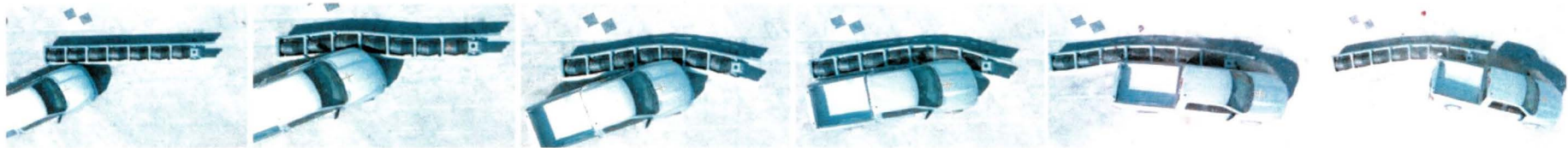

t = 0.000 sec

t = 0.050 sec

t = 0.100 sec

t = 0.150 sec

t = 0.250 sec

t = 0.350 sec

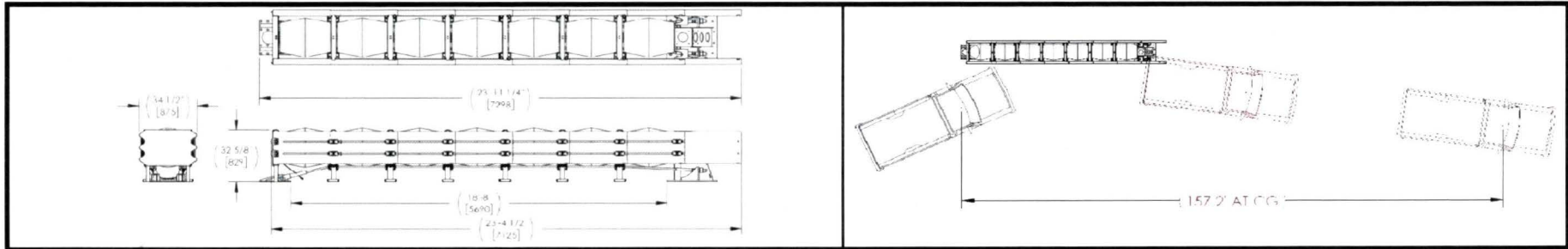

General Information

Test Agency..... **SAFE TECHNOLOGIES, INC.**
 Test Number..... TAU335-C1
 Test Designation MASH 3-35
 Date..... 5/2/2018

Test Article

Name Universal TAU-II-M, TL-3
 Type Redirective, Non-gating Crash Cushion
 Installation Length 287 1/4 in (7.30 m)
 Width 34 1/2 in (875 mm)
 Height 32 5/8 in (829 mm)

Test Vehicle

Type / Designation 2270P
 Make and Model 2011 Dodge Ram 1500
 Curb Weight 4,730 lb (2,145.5 kg)
 Test Inertial Weight 5,045 lb (2,288.5 kg)
 Gross Static Weight 5,045 lb (2,288.5 kg)

Impact Conditions

Speed 63.3 mph (101.9 km/h)
 Angle 25 deg
 Location / Orientation CIP at 3.9 ft (1.2 m) downstream from upstream end of right panel 1

Exit Conditions

Speed..... 53.6 mph (86.3 km/h)
 Angle..... 9 deg

Post Impact Trajectory

Vehicle Stability Satisfactory
 Longitudinal Stopping Distance (CG) 157.2 ft (47.9 m)
 Vehicle Snagging/Pocketing Minimal

Occupant risk Values

Longitudinal OIV 13.8 ft/s (4.2 m/s)
 Lateral OIV 20.3 ft/s (6.2 m/s)
 Longitudinal ORA 9.2 G
 Lateral ORA 11.1 G
 THIV 23.3 ft/s (7.1 m/s)
 PHD 13.5 G
 ASI 1.19

Test Article Damage:..... Minimal

Test Article Deflection

Longitudinal system stroke..... N/A
 Permanent lateral deflection 7.8 in (19.9 cm)
 Dynamic lateral deflection 19.6 in (49.8 cm)

Vehicle Damage

VDS..... 11-LFQ-3
 CDC..... 11LDEW2
 Maximum Interior Deformation 0.25 in (6.4 mm) in the driver

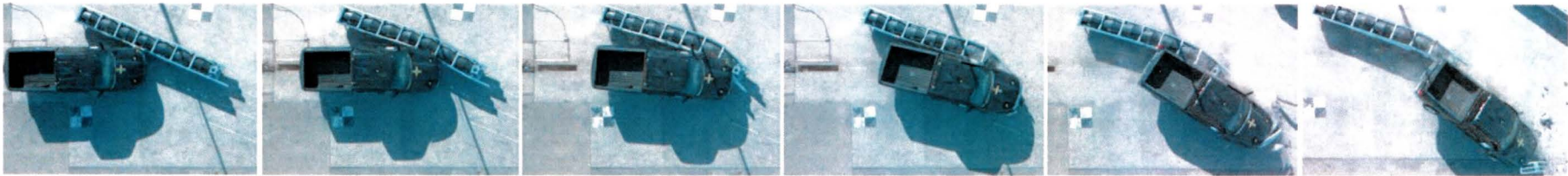

t = 0.000 sec

t = 0.050 sec

t = 0.100 sec

t = 0.150 sec

t = 0.250 sec

t = 0.350 sec

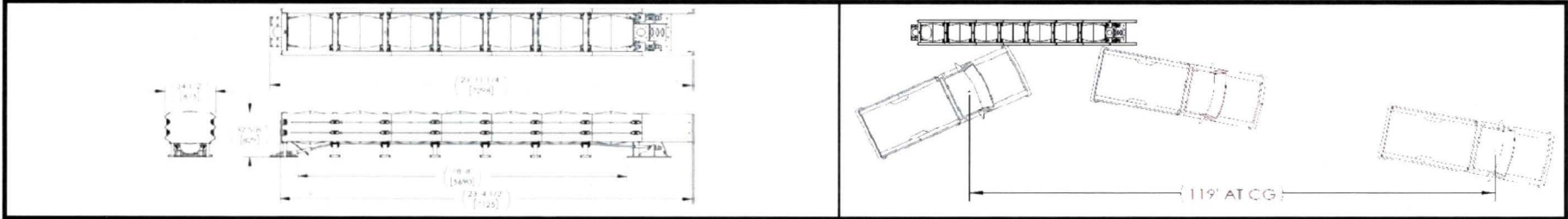

General Information

Test Agency.....SAFE TECHNOLOGIES, INC.
 Test Number.....TAU336-C1
 Test Designation.....MASH 3-36
 Date.....12/18/2017

Test Article

Name.....Universal TAU-M, TL-3
 Type.....Redirective, Non-gating Crash Cushion
 Installation Length.....287 1/4 in (7.30 m)
 Width.....34 1/2 in (875 mm)
 Height.....32 5/8 in (829 mm)

Test Vehicle

Type / Designation.....2270P
 Make and Model.....2011 Dodge Ram 1500
 Curb Weight.....4,888 lb (2,217 kg)
 Test Inertial Weight.....5,051 lb (2,291 kg)
 Gross Static Weight.....5,051 lb (2,291 kg)

Impact Conditions

Speed.....61.9 mph (99.6 km/h)
 Angle.....25.0 deg
 Location / Orientation.....9.4 ft (2.9 m) downstream
 from upstream end

Exit Conditions

Speed.....45 mph (72.3 km/h)
 Angle.....11 deg

Post Impact Trajectory

Vehicle Stability.....Satisfactory
 Longitudinal Stopping Distance (CG).....119 ft (36.3 m)
 Vehicle Snagging/Pocketing.....None

Occupant risk Values

Longitudinal OIV.....24.3 ft/s (7.4 m/s)
 Lateral OIV.....22.3 ft/s (6.8 m/s)
 Longitudinal ORA.....14.7 G
 Lateral ORA.....15.0 G
 THIV.....36.4 ft/s (11.1 m/s)
 PHD.....18.1 G
 ASI.....1.58

Test Article Damage:

Moderate

Test Article Deflections

Longitudinal System Stroke.....N/A
 Permanent Lateral Deflection.....7.7 in (19.5 cm)
 Dynamic Lateral Deflection.....18.1 in (46.0 cm)

Vehicle Damage

VDS.....11-LFQ-6
 CDC.....11LFES3
 Maximum Deformation.....4.6 in (117 mm)-toe pan area

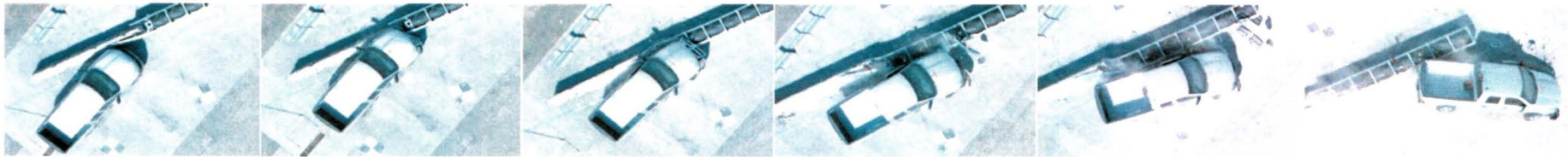

t = 0.000 sec

t = 0.050 sec

t = 0.100 sec

t = 0.200 sec

t = 0.300 sec

t = 0.600 sec

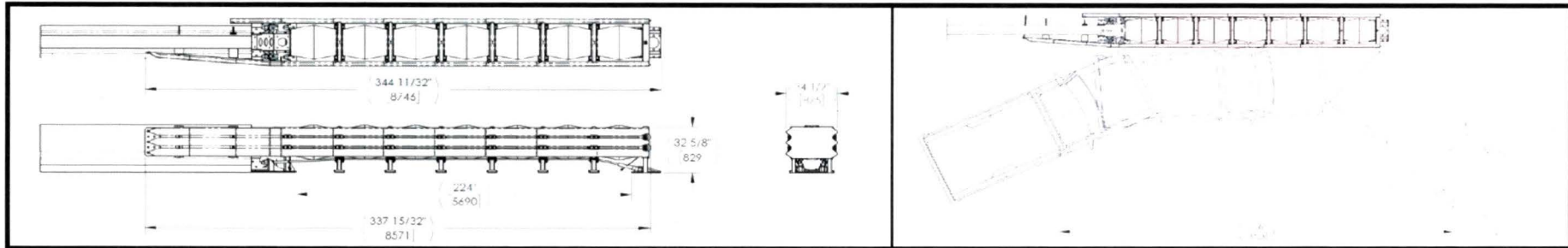

General Information

Test Agency..... **SAFE TECHNOLOGIES, INC.**
 Test Number..... TAU337a-C1
 Test Designation MASH 3-37a
 Date..... 5/22/2018

Test Article

Name Universal TAU-M, TL-3
 Type Redirective, Non-gating Crash Cushion
 Installation Length 344 11/32 in (8.75 m)
 Width 34 1/2 in (875 mm)
 Height 32 5/8 in (829 mm)

Test Vehicle

Type / Designation 2270P
 Make and Model 2011 Dodge Ram 1500
 Curb Weight 4965 lb (2,252 kg)
 Test Inertial Weight 4,986 lb (2,261.5 kg)
 Gross Static Weight 4,986 lb (2,261.5 kg)

Impact Conditions

Speed 62.3 mph (100.2 km/h)
 Angle 25 deg
 Location / Orientation Reverse CIP at 14.2 in (36.0 cm) from upstream end of the Terminal Shoe

Exit Conditions

Speed..... 42.9 mph (69.0 km/h)
 Angle..... 13 deg

Post Impact Trajectory

Vehicle Stability Satisfactory
 Longitudinal Stopping Distance (CG) 116 ft (35.3 m)
 Vehicle Snagging/Pocketing Minimal

Occupant risk Values

Longitudinal OIV 30.8 ft/s (9.4 m/s)
 Lateral OIV 25.3 ft/s (7.7 m/s)
 Longitudinal ORA 17.9 G
 Lateral ORA 9.2 G
 THIV 38.7 ft/s (11.8 m/s)
 PHD 19.1 G
 ASI 1.95

Test Article Damage:..... Minimal

Test Article Deflection

Longitudinal system stroke..... N/A
 Permanent lateral deflection 5.1 in (12.9 cm)
 Dynamic lateral deflection 18.3 in (46.4 cm)

Vehicle Damage

VDS..... 11-LFQ-6
 CDC..... 11LDEW2
 Maximum Interior Deformation 7.5 in (191 mm),

TEST LEVEL 3 - 7 BAY

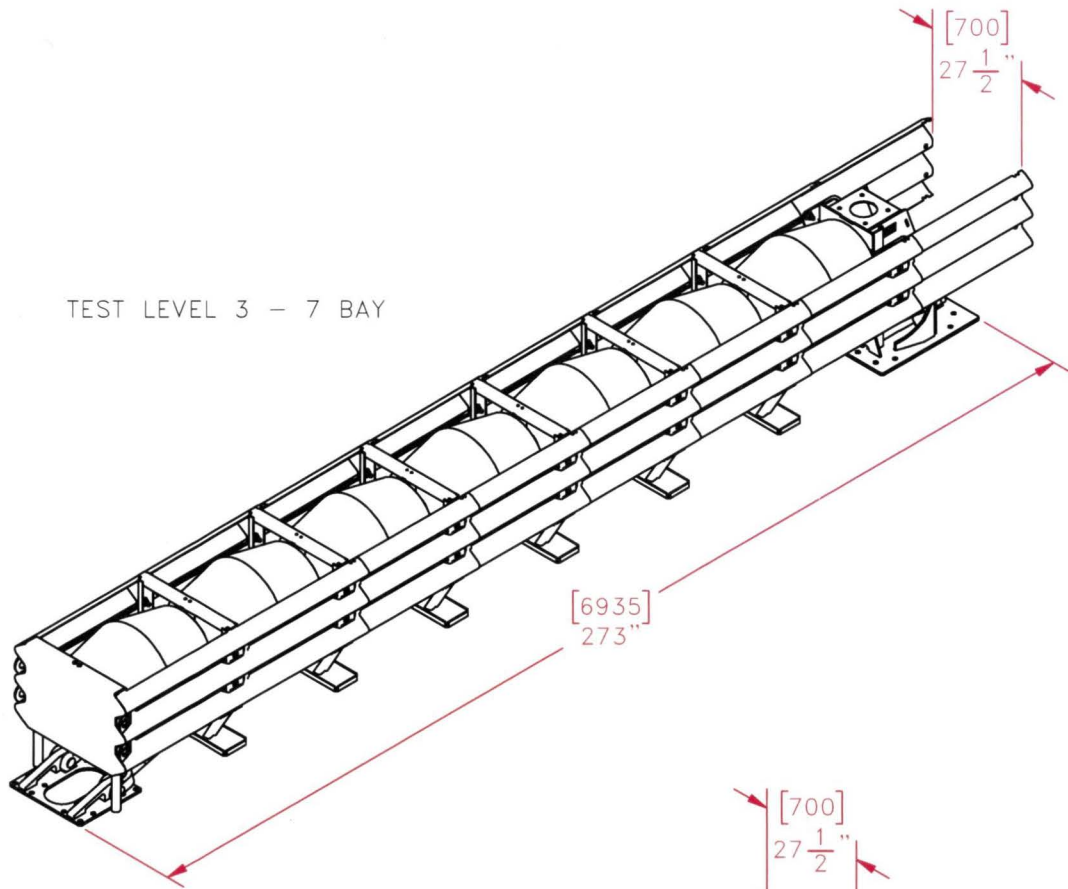

TEST LEVEL 2 - 4 BAY

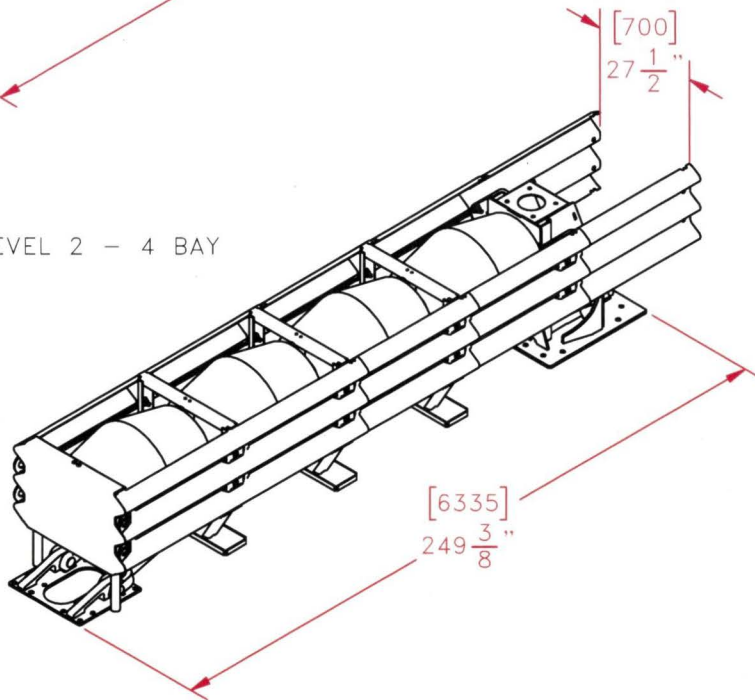

Universal TAU-M™



INTENDED USE

The Universal TAU-M™ system is a re-directive non-gating crash cushion and is ideally suited for hazards such as the ends of rigid barriers, tollbooths, utility poles, and more. This system is designed to reduce severity of an errant vehicle impact and to safely stop or redirect an errant vehicle away from roadside or median hazards. These types of systems are typically applied to locations where head-on and angled impacts are likely to occur and it is desirable to have the majority of post impact trajectories on the impact side of the system.

The Universal TAU-M™ parallel crash cushions can protect hazards up to 30" [762] and offers a variety of anchoring options to fit many applications. Standard non-proprietary three-beam transitions may enable protecting much wider hazards. Test Level 2 systems are 4 Bays and Test Level 3 systems are 7 Bays.

The TAU-II™ (SCT01a-b) may be converted to a TAU-M.

APPROVALS

The Universal TAU-M™ system has been fully tested in conformance with MASH Test Level 2 and Test Level 3 and is determined eligible for Federal reimbursement by FHWA.

FHWA Eligibility Letters: XXXXXXXX

CONTACT INFORMATION

Lindsay Transportation Solutions
180 River Rd.
Rio Vista, CA 94571
www.barriersystemsinc.com
Phone: 888-800-3691 or 707-374-6800
Fax: 707-374-6801
Email: info@barriersystemsinc.com

Universal TAU-M™



SHEET NO. DATE:
2 OF 2 08/24/18

Lindsay Transportation Solutions, 180 River Rd., Rio Vista CA. 94571, 888-800-3691
www.theroadzipper.com