

TOP VIEW

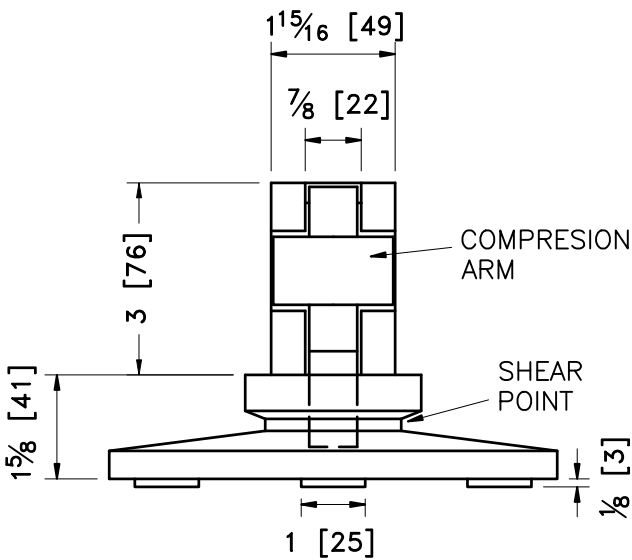

FRONT

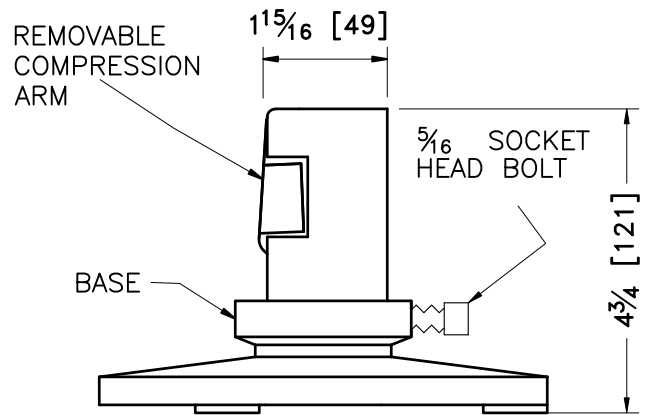

SIDE

2008

SNAP'n SAFE ROUND POST  
SURFACE MOUNT BREAKAWAY COUPLER



**DESIGNOVATIONS, INC.**

7339 WILDWOOD ROAD • STILLMAN VALLEY, IL 61084

PHONE: 888-868-6588 • FAX: 815-645-2389

EMAIL: sales@designovations.com • www.designovations.com

FMC02

SHEET NO.	REF. NO.
1 of 1	DV-04

## COMPONENT SPECIFICATIONS

### SPECIFICATIONS

The SNAP'n SAFE Round Post Surface Mount Breakaway Couplers are manufactured with cast grey iron and are zinc coated according to AASHTO M111 (ASTM 123). The same size coupler is used with PTP30 or any round steel post 2 3/8" [60 mm] diameter (8-16 gauge).

Dimensional tolerances not shown or implied are intended to be those consistent with the proper functioning of the part, including its appearance and accepted manufacturing practices.

### INTENDED USE

The SNAP'n SAFE Round Post Surface Mount Coupler mounts directly to concrete with three bolts. The sign post fits over the coupler and is secured with one bolt. At impact, the sign post breaks away at the coupling and does not strike the roof or windshield of the vehicle. In addition, concrete boring for an anchor post is eliminated.

### ACCEPTANCE

George E. Rice, Jr., Letter to Jim Anderson, Geometric and Roadside Design Acceptance Letter HSSD/SS-156, Federal Highway Administration, Washington, D.C., December 6, 2007.

### CONTACT INFORMATION

Designovations, Inc.  
7339 Wildwood Road  
Stillman Valley, IL. 61084  
Phone: 1-888-868-6588  
Fax: 1-815-645-2389  
Email: [Jim@Designovations.com](mailto:Jim@Designovations.com)  
Website: [www.designovations.com](http://www.designovations.com)

## SNAP'n SAFE Round Post Surface Mount Breakaway Coupler

**FMC02**

SHEET NO.

DATE

1 of 1

09-28-10



**DESIGNOVATIONS, INC.**

7339 WILDWOOD ROAD • STILLMAN VALLEY, IL 61084

PHONE: 888-868-6588 • FAX: 815-645-2389

EMAIL: [sales@designovations.com](mailto:sales@designovations.com) • [www.designovations.com](http://www.designovations.com)