

TOP

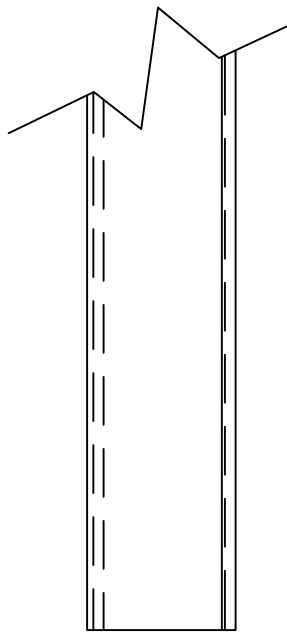

SIDE

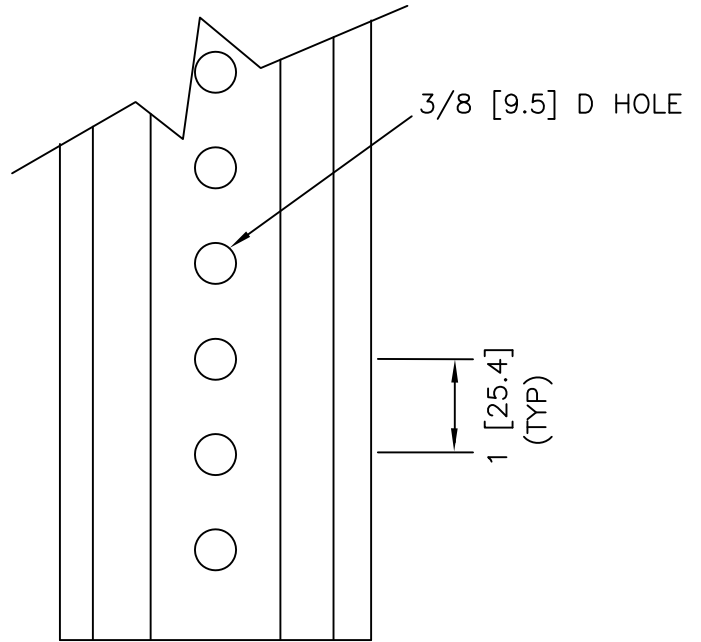

FRONT

DESIGNATOR	MASS*		DIMENSIONS*							
	lb/ft	kg/m	A		B		C		D	
PFP40	1.12	1.67	7/8	22.1	2 1/4	57.2	13/16	21.6	3/8	9.7

* ±5%

UNITS: IN [MM]

U-CHANNEL DELINEATOR POST



PFP40

SHEET NO.	DATE:
1 of 2	04/01/2012

SPECIFICATIONS

Posts shall be a uniform, modified, flanged channel section. Nucor Steel Marion Inc U-Channel Delineator Posts shall be fabricated from hot rolled carbon steel bars conforming to the requirements of Nucor Steel Marion Inc. Grade SP-80 (Standard) or ASTM Grade A-36 (Bend-Bak). The cast heat analysis of the steel shall conform to the following requirements:

SP-80 (Chemistry: A-1, Mechanical: A-499)		A-36	
Yield (min)	80,000 psi (552 Mpa)	Yield (min)	36,000 psi (248 Mpa)
Tensile (min)	100,000 psi (690 Mpa)	Tensile (min)	58,000 psi (400 Mpa)
<u>Element</u>	<u>Composition (%)</u>	<u>Element</u>	<u>Composition (%)</u>
Carbon	0.70 - 0.80	Carbon	0.70-0.80
Manganese	0.70 - 1.00	Manganese	N/A
Phosphorus (max)	0.035	Phosphorus (max)	0.035
Sulphur (max)	0.04	Sulphur (max)	0.04

Posts shall be machine straightened to have a smooth uniform finish, free from defects affecting their strength, durability, or appearance. All holes and rough edges shall be free from burrs. The permissible tolerance for straightness shall be 1/4 [6] over 60 [1524]. Posts shall be punched with continuous 1/4 [6] or 3/8 [9.5] or 7/16 [11] D holes on 1 [25] centers for the entire length of the post. The first hole shall be 1 [25] from the top of the post. After fabrication, posts may be polyester powder coated or galvanized. Galvanizing shall be in accordance with the requirements of ASTM A123.

Post Designator	Area (in ² mm ²)	I _x (in ⁴ mm ⁴ x 10 ³)	I _y (in ⁴ mm ⁴ x 10 ³)	S _x (in ³ mm ³)	S _y (in ³ mm ³)
PFP40	0.29 [187]	0.03 [12.5]	0.13 [54.1]	0.05 [819]	0.11 [1803]
PFP41	0.33 [213]	0.03 [12.5]	0.15 [62.4]	0.06 [983]	0.13 [2130]

Dimensional tolerances not shown or implied are intended to be those consistent with the proper functioning of the part, including its appearance and accepted manufacturing practices. All section properties are calculated based with a 3/8 [9.5] hole.

APPROVALS

FHWA Acceptance Letter [SS-42](#), November 10, 1993

CONTACT INFORMATION

Nucor Steel Marion Inc., 912 Cheney Avenue, Marion, Ohio 43301-1801
 (800) 333-4011
 (740) 383-6429 Fax
www.nucorhighway.com

** All Nucor Steel Marion Inc. products are produced from 100% recycled steel.*



U-CHANNEL DELINEATOR POST

PFP40-41		NUCOR <small>BAR MILL GROUP NUCOR STEEL MARION, INC.</small>	
SHEET NO.	DATE		
2 of 2	04/01/2012		