

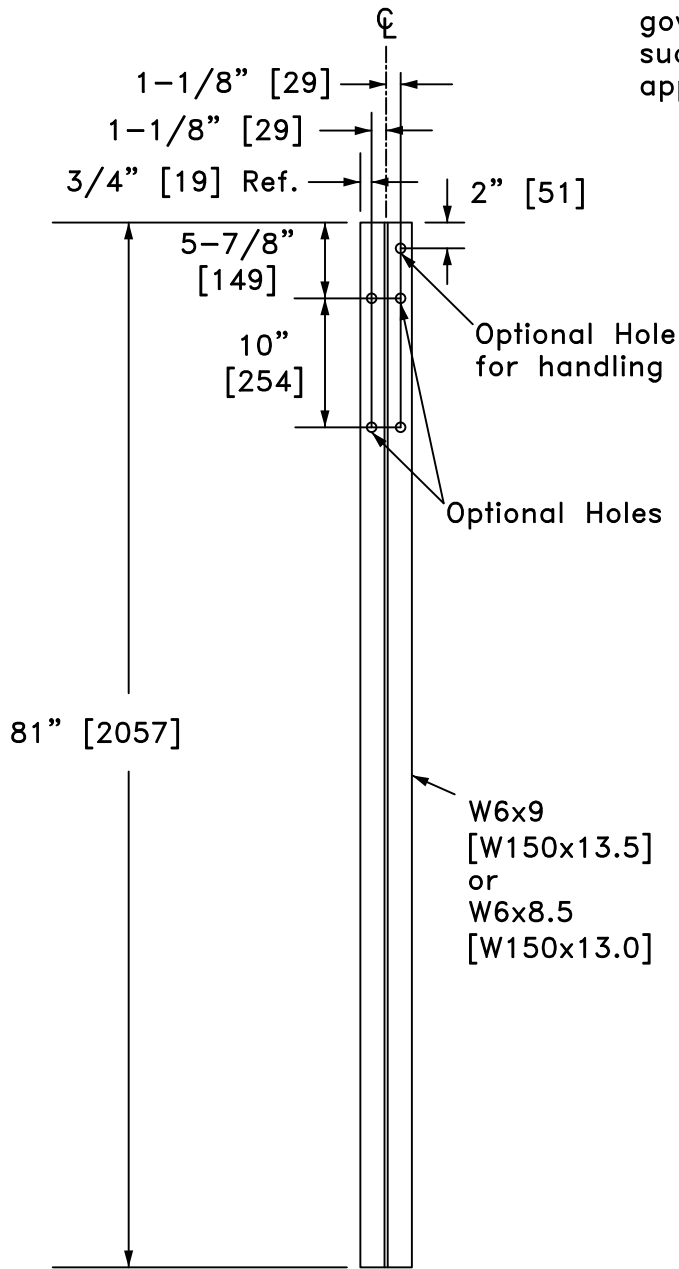

PLAN VIEW

NOTES:

- 1. All holes shown are 3/4" [19] or 13/16" [21] diameter.
- 2. Additional holes may be specified by governing agencies to accommodate items such as rubrails, double-sided applications, and future overlays.



FRONT/TRAFFIC-SIDE
ELEVATION VIEW

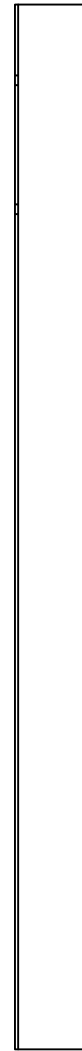

SIDE VIEW

WIDE-FLANGE GUARDRAIL POST



PWE04

SHEET NO.

DATE:

1 of 2

4/9/2019

SPECIFICATIONS

PWE04 guardrail posts shall be manufactured from steel that conforms to any of the following:

- AASHTO M 270/M 270M (ASTM A709/A709M), Grade 36 [250] or Grade 50S [345S] with the exception of supplementary requirements;
- ASTM A36/A36M; or,
- ASTM A992/A992M.

Where corrosion-resistant steel is required, PWE04 guardrail posts shall be manufactured from steel that conforms to the requirements of AASHTO M 270/M 270M (ASTM A709/A709M), Grade 50W [345W] with the exception of supplementary requirements or ASTM A588/A588M.

Dimensions of the guardrail posts cross-section shall conform to W6x9 [W150x13.5] or W6x8.5 [W150x13.0] wide-flange section in accordance with ASTM A6/A6M.

After the section is cut-to-length and all holes are drilled or punched, each guardrail post shall be zinc-coated (hot-dip galvanized) in accordance with AASHTO M 111 (ASTM A123) unless corrosion-resistant steel is used. Where corrosion-resistant steel is used, the portion of the post to be embedded in soil shall be zinc-coated (hot-dip galvanized) in accordance with AASHTO M 111 (ASTM A123) and the portion above the soil shall not be coated, painted, or otherwise treated.

Dimensional tolerances not shown or implied are intended to be those consistent with the proper functioning of the part, including its appearance and accepted manufacturing practices.

INTENDED USE

Post PWE04 is used with the following Systems:

- SGR09b, Modified Thrie-Beam Guardrail, Steel Posts, Steel Blockouts.
- SGM09b, Modified Thrie-Beam Median Barrier, Steel Posts, Steel Blockouts.

WIDE-FLANGE GUARDRAIL POST

PWE04



SHEET NO.

DATE

2 of 2

4/9/2019