

NOTE: ALL HOLES ARE
3/4 [20] D.

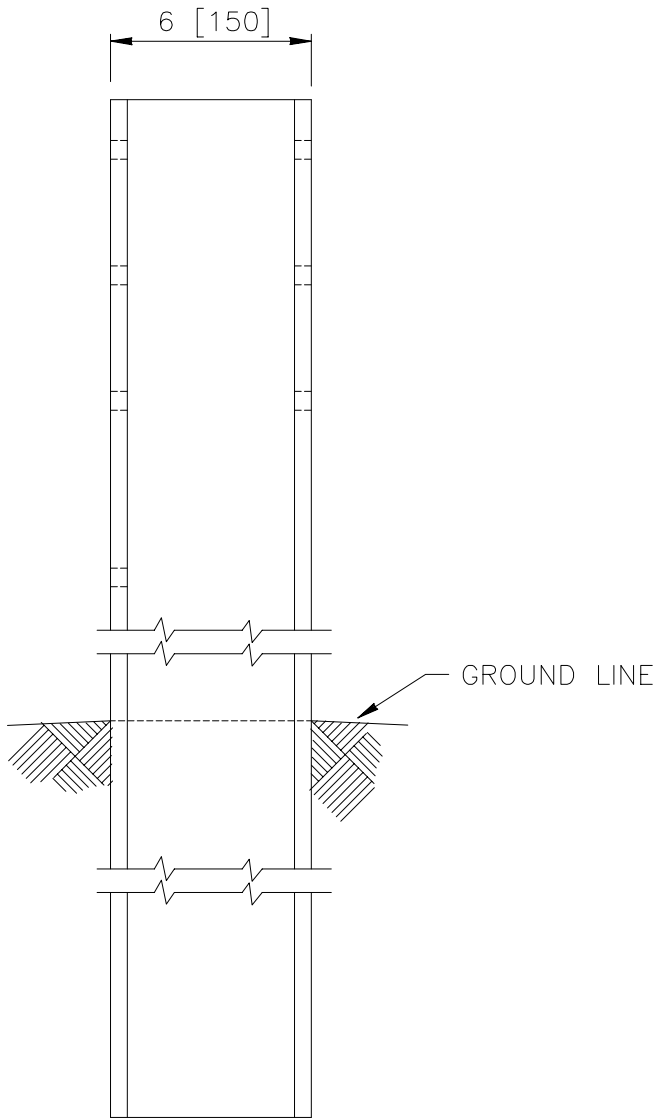

SIDE

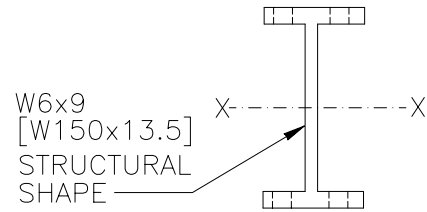
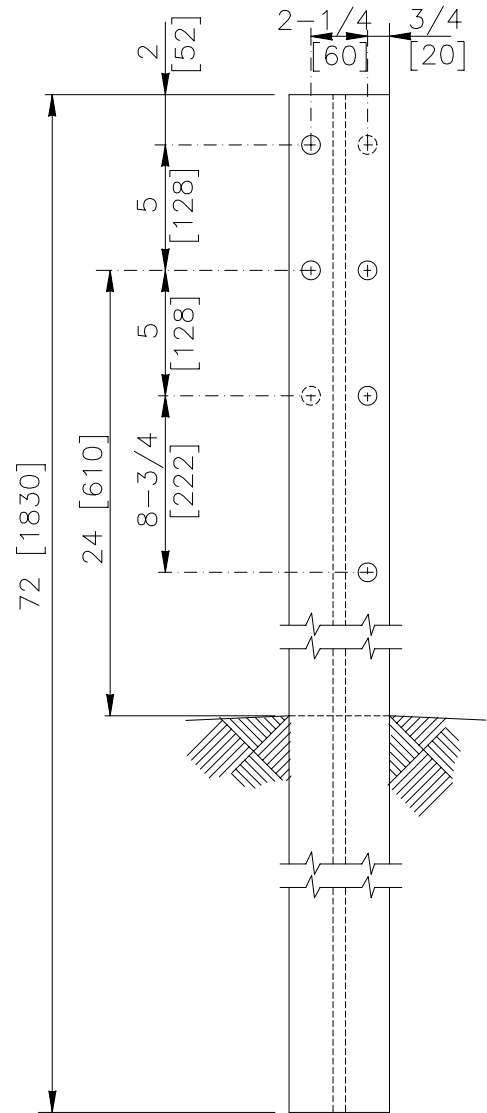

FRONT

1994

WIDE-FLANGE MEDIAN BARRIER POST

PWE05

SHEET NO.

DATE:

1 of 2

7/27/2005

SPECIFICATIONS

W-beam and thrie-beam guardrail posts shall be manufactured using AASHTO M 270 / M 270M (ASTM A 709 / A 709M) Grade 36 [250] steel unless corrosion-resistant steel is required, in which case the post shall be manufactured from AASHTO M 270 / M 270M (ASTM A 709 / A 709M) Grade 50W [345W] steel. The dimensions of the cross-section shall conform to a W6x9 [W150x13.5] section as defined in AASHTO M 160 / M 160M (ASTM A 6 / A 6M). [W150x12.6] wide flange posts are an acceptable alternative that is considered equivalent to the [W150x13.5].

After the section is cut and all holes are drilled or punched, the component should be zinc-coated according to AASHTO M 111 (ASTM A 123) unless corrosion-resistant steel is used. When corrosion-resistant steel is used, the portion of the post to be embedded in soil shall be zinc-coated according to AASHTO M 111 (ASTM A 123) and the portion above the soil shall not be zinc-coated, painted or otherwise treated.

Designator	Area in ² [10 ³ mm ²]	I _x in ⁴ [10 ⁶ mm ⁴]	I _y in ⁴ [10 ⁶ mm ⁴]	S _x in ³ [10 ³ mm ³]	S _y in ³ [10 ³ mm ³]
PWE05	2.63 [1.7]	16.43 [6.84]	2.19 [0.91]	5.57 [91.2]	1.11 [18.2]

Dimensional tolerances not shown or implied are intended to be those consistent with the proper functioning of the part, including its appearance and accepted manufacturing practices.

INTENDED USE

Post PWE05 is used with the SGM06a strong-post median barrier. Wood (PDB01b) or plastic blockouts are attached to each post using FBB03 bolts and nuts. Rub rail RER01 or RLR01 is attached to each post using an FBB03 bolt (trimmed to 4 inches [100 mm] long) and nut.

WIDE-FLANGE MEDIAN BARRIER POST

PWE05

SHEET NO.

DATE

2 of 2

7/25/2005