

PLAN

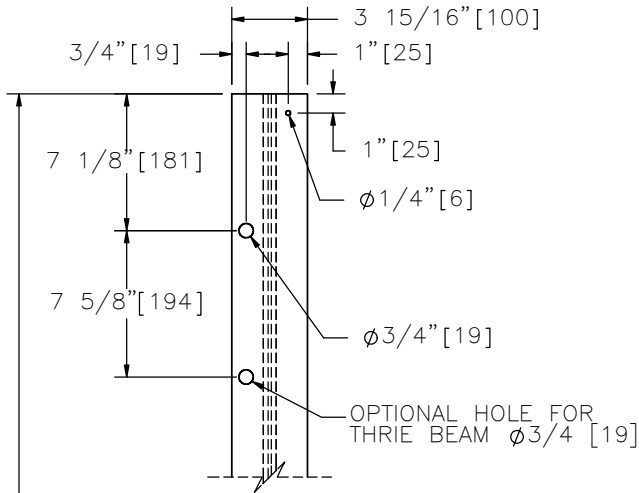

ELEVATION

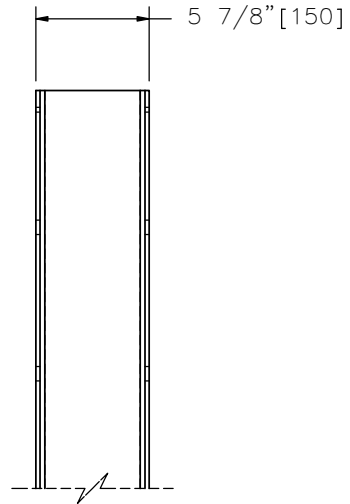

SIDE

DESIGNATOR	LENGTH, "L"
PWE06	72" [1829]
PWE07	84" [2134]
PWE08	108" [2743]
PWE09	78" [1981]

WIDE-FLANGE GUARDRAIL POST



PWE06-09

SHEET NO.

DATE:

1 of 2

9/8/2011

## SPECIFICATIONS

W-Beam and thrie-beam guardrail posts shall be manufactured using AASHTO M270M (ASTM A709M) Grade 250 steel or ASTM A36/A36M unless corrosion resistant steel is required in which case the post shall be manufactured from AASHTO M270M (ASTM A709M) Grade 50W steel. The dimensions of the cross-section shall conform a W6x9 [W150x13.4] section as defined in AASHTO M160M (ASTM A6M). W6x8.5 [W150x12.6] wide-flange posts are an acceptable alternative that is considered equivalent to the W6x9 [W150x13.4].

After the section is cut and all holes are drilled or punched, the component should be zinc-coated according to AASHTO M111 (ASTM A123) unless corrosion resistant steel is used. When corrosion resistant steel is used the portion of the post to be embedded in soil shall be zinc-coated according to AASHTO M111 (ASTM A123) and the portion above the soil shall not be zinc-coated, painted, or otherwise treated.

DESIGNATOR	AREA in. <sup>2</sup> [10 <sup>3</sup> mm <sup>2</sup> ]	I <sub>x</sub> in. <sup>4</sup> [10 <sup>6</sup> mm <sup>4</sup> ]	I <sub>y</sub> in. <sup>4</sup> [10 <sup>6</sup> mm <sup>4</sup> ]	S <sub>x</sub> in. <sup>3</sup> [10 <sup>3</sup> mm <sup>3</sup> ]	S <sub>y</sub> in. <sup>3</sup> [10 <sup>3</sup> mm <sup>3</sup> ]
PWE06-09	2.68 [1.7]	16.4 [6.83]	2.20 [0.92]	5.56 [91.1]	1.11 [18.2]

Dimensional tolerances not shown or implied are intended to be those consistent with the proper functioning of the part, including its appearance and accepted manufacturing practices.

## INTENDED USE

Post PWE06-09 is used with a number of Midwest Guardrail System variations, including SGR20a, SGR21a, SGR22a, SGR23a, SGR24a, SGR26a, SGR38a, STG02, and STG03a. The post is typically attached to a Thrie Beam rail section, such as RWM04a or RWT02, utilizing a guardrail bolt and nut like FBB06.

## CONTACT INFORMATION

Midwest Roadside Safety Facility  
Nebraska Transportation Center  
University of Nebraska-Lincoln  
130 Whittier Research Center  
2200 Vine Street  
Lincoln, NE 68583-0853  
(402) 472-0965  
Email: [mwrfsf@unl.edu](mailto:mwrfsf@unl.edu)  
Website: <http://mwrfsf.unl.edu/>

## WIDE-FLANGE GUARDRAIL POST

PWE06-09



SHEET NO.

DATE:

2 of 2

9/8/2011