

1. Report No. FHWA/TX-04/4852-1		2. Government Accession No.		3. Recipient's Catalog No.	
4. Title and Subtitle CRASH TESTING AND EVALUATION OF THE MODIFIED T77 BRIDGE RAIL				5. Report Date September 2003	
				6. Performing Organization Code	
7. Author(s) D. Lance Bullard, Jr., C. E. Buth, William F. Williams, Wanda L. Menges, and Rebecca R. Haug				8. Performing Organization Report No. Report 4852-1	
9. Performing Organization Name and Address Texas Transportation Institute The Texas A&M University System College Station, Texas 77843-3135				10. Work Unit No. (TRAIS)	
				11. Contract or Grant No. Project No. 0-4852	
12. Sponsoring Agency Name and Address Texas Department of Transportation Research and Technology Implementation Office P.O. Box 5080 Austin, Texas 78763-5080				13. Type of Report and Period Covered Research: August 2002 – July 2003	
				14. Sponsoring Agency Code	
15. Supplementary Notes Research performed in cooperation with the Texas Department of Transportation and the U.S. Department of Transportation, Federal Highway Administration. Research Project Title: Development of the T77 Bridge Rail					
16. Abstract <p>Under a previous study, Texas Transportation Institute (TTI) and TxDOT worked cooperatively to conceptualize and develop two aesthetically pleasing and crashworthy rail designs. The rails were designated the T77 and the F411. Researchers performed and evaluated full-scale crash tests on the new rails in accordance with <i>National Cooperative Highway Research Program (NCHRP) Report 350</i> test 3-11. The TxDOT F411 bridge rail performed acceptably according to the evaluation criteria of <i>NCHRP Report 350</i>. However, the T77 design failed to perform acceptably with the pickup truck.</p> <p>The objective of this project was to modify the TxDOT T77 bridge rail to perform as an aesthetically pleasing and crashworthy bridge rail. TTI and TxDOT worked cooperatively to modify the design to make the rail perform satisfactorily. Researchers performed full-scale crash tests in accordance with <i>NCHRP Report 350</i>. The T77 bridge rail was modified so it would perform in accordance with the evaluation criteria for <i>NCHRP Report 350</i> test 3-11.</p>					
17. Key Words Bridge Rails, Roadside Safety, Aesthetic Rails, Concrete Rails, Longitudinal Barriers			18. Distribution Statement No restrictions. This document is available to the public through NTIS: National Technical Information Service 5285 Port Royal Road Springfield, Virginia 22161		
19. Security Classif.(of this report) Unclassified		20. Security Classif.(of this page) Unclassified		21. No. of Pages 88	22. Price

CRASH TESTING AND EVALUATION OF THE MODIFIED T77 BRIDGE RAIL

by

D. Lance Bullard, Jr., P.E.
Associate Research Engineer
Texas Transportation Institute

C. E. Buth, Ph.D., P.E.
Senior Research Engineer
Texas Transportation Institute

William F. Williams, P.E.
Assistant Research Engineer
Texas Transportation Institute

Wanda L. Menges
Associate Research Specialist
Texas Transportation Institute

and

Rebecca R. Haug
Assistant Research Specialist
Texas Transportation Institute

Report 4852-1
Project Number 0-4852
Research Project Title: Development of the T77 Bridge Rail

Sponsored by the
Texas Department of Transportation
In Cooperation with the
U.S. Department of Transportation
Federal Highway Administration

September 2003

TEXAS TRANSPORTATION INSTITUTE
The Texas A&M University System
College Station, Texas 77843-3135

DISCLAIMER

The contents of this report reflect the views of the authors, who are responsible for the facts and the accuracy of the data, and the opinions, findings, and conclusions presented herein. The contents do not necessarily reflect the official view or policies of the Texas Department of Transportation (TxDOT), Federal Highway Administration (FHWA), the Texas A&M University System, or the Texas Transportation Institute. This report does not constitute a standard, specification, or regulation, and its contents are not intended for construction, bidding, or permit purposes. In addition, the above listed agencies assume no liability for its contents or use thereof. The names of specific products or manufacturers listed herein do not imply endorsement of those products or manufacturers. The engineer in charge was D. Lance Bullard, Jr., P.E., (Texas, #86842).

ACKNOWLEDGMENTS

This research project was conducted under a cooperative program between the Texas Transportation Institute, the Texas Department of Transportation, and the U.S. Department of Transportation, Federal Highway Administration. The authors acknowledge and appreciate the guidance of the TxDOT project director for this research, Mr. Mark Bloschock, P.E. The authors also would like to acknowledge Mr. Dean Van Landuyt for his conceptualization of the T77 rail.

TABLE OF CONTENTS

	<u>Page</u>
LIST OF FIGURES	ix
LIST OF TABLES	xi
CHAPTER 1. INTRODUCTION	1
PROBLEM.....	1
BACKGROUND	1
OBJECTIVES/SCOPE OF RESEARCH	1
CHAPTER 2. STUDY APPROACH.....	3
TEST FACILITY	3
TEST ARTICLE	3
CRASH TEST CONDITIONS	5
EVALUATION CRITERIA	13
CHAPTER 3. CRASH TEST RESULTS	15
TEST NO. 448523-1 (<i>NCHRP Report 350</i> TEST NO. 3-11).....	15
Test Vehicle	15
Soil and Weather Conditions	15
Test Description	15
Damage to Test Installation	18
Vehicle Damage.....	18
Occupant Risk Factors	18
Assessment of Test Results.....	24
TEST NO. 409260-1 (<i>NCHRP Report 350</i> TEST NO. 3-11).....	27
Test Vehicle	27
Soil and Weather Conditions	27
Test Description	27
Damage to Test Installation	30
Vehicle Damage.....	30
Occupant Risk Factors	30
Assessment of Test Results.....	37
CHAPTER 4. SUMMARY AND CONCLUSIONS	41
SUMMARY OF TEST RESULTS.....	41
Test 448523-1	41
Test 409260-1	41
CONCLUSIONS.....	41
CHAPTER 5. IMPLEMENTATION STATEMENT.....	45
REFERENCES	47

TABLE OF CONTENTS (continued)

	<u>Page</u>
APPENDIX A. CRASH TEST PROCEDURES AND DATA ANALYSIS	49
ELECTRONIC INSTRUMENTATION AND DATA PROCESSING	49
ANTHROPOMORPHIC DUMMY INSTRUMENTATION.....	50
PHOTOGRAPHIC INSTRUMENTATION AND DATA PROCESSING	50
TEST VEHICLE PROPULSION AND GUIDANCE.....	50
APPENDIX B. TEST VEHICLE PROPERTIES AND INFORMATION	51
APPENDIX C. SEQUENTIAL PHOTOGRAPHS	57
APPENDIX D. VEHICLE ANGULAR DISPLACEMENTS AND ACCELERATIONS	63

LIST OF FIGURES

<u>Figure</u>		<u>Page</u>
1	Details of the Layout of the Modified T77 Bridge Rail.....	6
2	Cross Section of the Modified T77 Bridge Rail.	7
3	Post and Baseplate Details of the Modified T77 Bridge Rail.	8
4	Post and Baseplate Connection Details of the Modified T77 Bridge Rail.	9
5	Rail Connection Details of the Modified T77 Bridge Rail.	10
6	Modified T77 Bridge Rail Before Test 448523-1.....	11
7	Modified T77 Bridge Rail Before Test 409260-1.....	12
8	Vehicle/Installation Geometrics for Test 448523-1.....	16
9	Vehicle Before Test 448523-1.....	17
10	After Impact Trajectory for Test 448523-1.	19
11	Installation After Test 448523-1.....	20
12	Vehicle After Test 448523-1.	21
13	Interior of Vehicle for Test 448523-1.....	22
14	Summary of Results for Test 448523-1, <i>NCHRP Report 350</i> Test 3-11.....	23
15	Vehicle/Installation Geometrics for Test 409260-1.....	28
16	Vehicle Before Test 409260-1.....	29
17	After Impact Trajectory for Test 409260-1.	31
18	Installation After Test 409260-1.....	32
19	Vehicle After Test 409260-1.	34
20	Interior of Vehicle for Test 409260-1.....	35
21	Summary of Results for Test 409260-1, <i>NCHRP Report 350</i> Test 3-11.....	36
22	Vehicle Properties for Test 448523-1.....	51
23	Vehicle Properties for Test 409260-1.....	54
24	Sequential Photographs for Test 448523-1 (Overhead and Frontal Views).....	57
25	Sequential Photographs for Test 448523-1 (Rear View).....	59
26	Sequential Photographs for Test 409260-1 (Overhead and Frontal Views).....	60
27	Sequential Photographs for Test 409260-1 (Rear View).....	62
28	Vehicular Angular Displacements for Test 448523-1.....	63
29	Vehicle Longitudinal Accelerometer Trace for Test 448523-1 (Accelerometer Located at Center of Gravity).	64
30	Vehicle Lateral Accelerometer Trace for Test 448523-1 (Accelerometer Located at Center of Gravity).	65
31	Vehicle Vertical Accelerometer Trace for Test 448523-1 (Accelerometer Located at Center of Gravity).	66
32	Vehicle Longitudinal Accelerometer Trace for Test 448523-1 (Accelerometer Located Over Rear Axle).	67
33	Vehicle Lateral Accelerometer Trace for Test 448523-1 (Accelerometer Located Over Rear Axle).	68

LIST OF FIGURES (continued)

<u>Figure</u>		<u>Page</u>
34	Vehicle Vertical Accelerometer Trace for Test 448523-1 (Accelerometer Located Over Rear Axle).....	69
35	Vehicular Angular Displacements for Test 409260-1.	70
36	Vehicle Longitudinal Accelerometer Trace for Test 409260-1 (Accelerometer Located at Center of Gravity).....	71
37	Vehicle Lateral Accelerometer Trace for Test 409260-1 (Accelerometer Located at Center of Gravity).....	72
38	Vehicle Vertical Accelerometer Trace for Test 409260-1 (Accelerometer Located at Center of Gravity).....	73
39	Vehicle Longitudinal Accelerometer Trace for Test 409260-1 (Accelerometer Located Over Rear Axle).....	74
40	Vehicle Lateral Accelerometer Trace for Test 409260-1 (Accelerometer Located Over Rear Axle).....	75
41	Vehicle Vertical Accelerometer Trace for Test 409260-1 (Accelerometer Located Over Rear Axle).....	76

LIST OF TABLES

<u>Table</u>		<u>Page</u>
1	Performance Evaluation Summary for Test 448523-1, <i>NCHRP Report 350</i> Test 3-11	42
2	Performance Evaluation Summary for Test 409260-1, <i>NCHRP Report 350</i> Test 3-11	43
3	Exterior Crush Measurements for Test 448523-1	52
4	Occupant Compartment Measurements for Test 448523-1	53
5	Exterior Crush Measurements for Test 409260-1	55
6	Occupant Compartment Measurements for Test 409260-1	56

CHAPTER 1. INTRODUCTION

PROBLEM

Texas Department of Transportation (TxDOT) frequently receives requests from districts and the public to provide aesthetically pleasing traffic rails for use on select bridges and roadways. Such rails are normally installed along designated scenic or historic routes and various types of urban facilities. Although aesthetic rails are generally more expensive to construct, their cost is only a fraction of the total cost of a bridge. Typically, aesthetic rails are ornate and have an open architecture that may compromise their crashworthiness. If not properly designed, vertical and horizontal openings in these barriers provide the opportunity for vehicle snagging, which can produce undesirable decelerations or occupant compartment intrusion. Traffic barriers are frequently designed for high-speed facilities (i.e., > 60 mph), which exacerbates the potential problems that surface asperities found in aesthetic applications present. TxDOT is seeking to expand the number of aesthetically pleasing traffic rails available to the motoring public that meet *National Cooperative Highway Research Program (NCHRP) Report 350* Test Level 3 (TL-3) impact conditions (1).

BACKGROUND

TxDOT, in response to providing context sensitive design alternatives to the public, initiated a prior project (2) to develop additional aesthetically pleasing rail alternatives. Texas Transportation Institute (TTI) and TxDOT worked cooperatively to conceptualize and develop two aesthetically pleasing and crashworthy rail designs. The rails were designated the T77 and the F411. Researchers performed and evaluated full-scale crash tests on the new rails in accordance with *NCHRP Report 350* test 3-11. The TxDOT F411 bridge rail performed acceptably according to the evaluation criteria of *NCHRP Report 350*. However, the T77 design failed to perform acceptably with the pickup truck. Local rail deformation near the rail splice and the sleeve splice itself caused truck snagging and excessive occupant compartment deformation. TTI and TxDOT subsequently have worked to revise the T77 design to make it perform acceptably and in accordance with *NCHRP Report 350*. This report is the subject of the additional work and crash tests performed on the modified T77 to demonstrate its crashworthiness.

OBJECTIVES/SCOPE OF RESEARCH

The objective of this project was to modify the TxDOT T77 traffic rail to perform as an aesthetically pleasing and crashworthy traffic rail for use by TxDOT. Texas Transportation Institute and TxDOT worked cooperatively to modify the design to perform satisfactorily. Researchers performed and evaluated full-scale crash tests in accordance with *NCHRP Report 350*.

CHAPTER 2. STUDY APPROACH

TEST FACILITY

The test facilities at the Texas Transportation Institute's Proving Ground consist of a 2000-acre (809-hectare) complex of research and training facilities situated 10 mi (16 km) northwest of the main campus of Texas A&M University. The site, formerly an Air Force Base, has large expanses of concrete runways and parking aprons well suited for experimental research and testing in the areas of vehicle performance and handling, vehicle-roadway interaction, durability and efficacy of highway pavements, and safety evaluation of roadside safety hardware. The site selected for the placement of the T77 traffic rail is along a wide out-of-service apron/runway. The apron/runway consists of an unreinforced jointed concrete pavement in 12.5 ft by 15 ft (3.8 m by 4.6 m) blocks nominally 8 to 12 inches (203-305 mm) deep. The aprons and runways are about 50 years old and the joints have some displacement, but are otherwise flat and level.

TEST ARTICLE

The T77 failed to perform acceptably in a prior test (2) due to local rail deformation near a rail splice joint and the sleeve splice which caused the truck to experience snagging and excessive occupant compartment deformation. The impact of the pickup truck into the rail element caused local deformation of the rail element that ceased deforming at the intersection of the blunt end of the interior sleeve splice tube. In addition, some snagging of the pickup truck occurred in the splice joint between the rail element and the sleeve splice tube.

TTI designed, constructed, and crash tested a prototype steel aesthetic traffic rail designated as TxDOT Type T77. TTI Report No. 4288-1 (2), Appendix B, presents the design calculations for the first prototype T77 traffic rail. The total length of the railing installation was 75 ft (22.7 m). The first prototype T77 traffic railing system was a steel rail and post system consisting of two tubular steel rail elements mounted on 1-1/4 inch (32 mm) thick steel plate posts spaced 8 ft (2.4 m) apart. The elliptical-shaped rails were 8 inches \times 4-7/8 inches (203 mm \times 124 mm) and were manufactured from 6 inch (152 mm) diameter, API-5LX52 pipe with a wall thickness of 0.188 inch (6.4 mm). The center of the lower rail and the top of the upper rail measured 1 ft-6 inches (0.45 m) and 2 ft-9 inches (0.8 m), respectively, from the pavement surface. The rails were welded to the posts. The 1-1/4 inch (32 mm) thick posts were fabricated in the shape of the numeral "7" and were welded to 11-1/2 inch \times 12 inch \times 1-1/2 inch (292 mm \times 305 mm \times 38 mm) thick base plates. Each post was anchored to the curb using four 7/8 inch (22 mm) diameter A325 anchor bolts with a 7 inch \times 11 inch \times 1/4 inch (178 mm \times 279 mm \times 6 mm) thick anchor plate used for additional anchorage. The traffic railing system was supported by a cast-in-place concrete deck and curb. The curb was 14 inches (356 mm) wide and 9 inches (229 mm) high on the traffic side and 5-1/2 inches (140 mm) high on the field side. The top of the curb sloped downward approximately 14 degrees from horizontal toward the field side. The post base plates were sloped in a similar fashion so that the two rail elements were flush with the traffic side face of the curb. The post plates and base plates were manufactured from A572 grade

50 steel. Gordon Specialties, Inc., of Hutchins, Texas, fabricated the traffic rail. TTI fabricated the anchor plates.

The railing installation was constructed using 2 ft (0.6 m) long elliptical-shaped sleeve splices, which were also manufactured from 6 inch (152 mm) diameter API-5LX52 pipe formed into an 8 inch \times 4-7/8 inch (203 mm \times 124 mm) elliptical shape.

A simulated concrete bridge deck cantilever and curb was constructed adjacent to an existing concrete runway located at the TTI test facility. The total length of the installation was 75 ft (22.9 m). The bridge deck cantilever was 2 ft-5 inches (0.7 m) in width and 8 inches (203 mm) thick and was rigidly attached to an existing concrete foundation at the testing facility. A 1 ft-2 inch (0.4 m) wide concrete curb, 9 inches (229 mm) high on the traffic side and 5-1/2 inches (140 mm) wide on the field side was cast on top of the concrete deck. Transverse reinforcement in the deck consisted of two layers of #5's spaced 6 inches (152 mm) apart. Longitudinal reinforcement in the top layer of the deck consisted of two #4's spaced 10 inches (254 mm) apart closest to the field side edge with a third bar located approximately 6-3/4 inches (171 mm) away. Longitudinal reinforcement in the bottom layer of the deck consisted of two #5's located 3 inches (76 mm) apart closest to the field side edge with a third #5 bar located approximately 12 inches (305 mm) away. In addition to the deck reinforcement, #5 hoop-shaped "U" bars located 6 inches (152 mm) apart were cast in the deck for reinforcement for the concrete curb. Longitudinal reinforcement in the curb consisted of two #5 bars equally spaced in the top of the "U" bars. All reinforcement used in the top layer of the deck was epoxy coated. All other reinforcement was bare steel (not epoxy coated). All reinforcement had a specified minimum yield strength of 60 ksi (414 MPa).

Standard concrete compressive strength cylinders were cast for both the concrete deck and curb. For the concrete deck, strength tests performed after aging 11 days resulted in an average compressive strength of 4155 psi (28,648 kPa). For the concrete curb, strength tests performed at 7 days age resulted in an average compressive strength of 3728 psi (26,704 kPa).

To improve the performance of the T77 rail, TTI increased the wall thickness of the 8 inches \times 4-7/8 inches (203 mm \times 124 mm) elliptical-shaped rails that were manufactured from API-5LX52 pipe with a wall thickness of 0.188 inch (6.4 mm) to a 6 inches (152 mm) diameter, schedule 40 pipe with a wall thickness of 0.280 inch (6.4 mm). Additionally, the elliptical sleeve splices were chamfered 1 inch (25 mm) in the lateral direction toward the center of the rail.

Crash test 448523-1, presented later in this report, was performed and the rail demonstrated some improved performance. However, the leading edge of the front wheel rim gouged into and snagged in between the rail element and the sleeve splice causing excessive occupant compartment deformation. Thereafter, TTI redesigned the sleeve splice to reduce the potential for snagging.

The railing installation prepared for crash test 409260-1 and the final T77 test installation were constructed using newly developed 3 ft (0.914 m) long elliptical-shaped two-part sleeve splices, which were manufactured from a 6 inches (152 mm) diameter API-5LX52 pipe formed into an elliptical shape. The two-part sleeve splices were fabricated with an adjusting

mechanism within the splice. This adjusting mechanism, which incorporated a 1 inch (25mm) thick plate with a threaded hole for a 1 inch (25 mm) diameter Grade 5 machine bolt and a 1 inch (25mm) thick bearing plate, was used to expand the splice inside the rail to obtain a secure splice fit. The splices were constructed with a close-fitting tolerance and provided approximately 1 inch of rail expansion at each splice. These splices were located 1 ft (0.3 m) from posts 4 and 7.

Figures 1 through 4 illustrate details of the T77 rail. Figure 5 illustrates the new TTI sleeve splice and Figures 6 and 7 show photographs of the completed installation.

CRASH TEST CONDITIONS

According to *NCHRP Report 350*, two crash tests are recommended for test level 3 evaluation of length-of-need longitudinal barriers:

NCHRP Report 350 Test Designation 3-10: 820C vehicle impacting the length of need section at a speed of 62.1 mph (100 km/h) at an impact angle of 20 degrees.

NCHRP Report 350 Test Designation 3-11: 2000P vehicle impacting the length of need section at a speed of 62.1 mph (100 km/h) at an impact angle of 25 degrees.

Test 3-10 was successfully performed in a previous study (2). The pickup truck test is performed for the purpose of evaluating the strength of the section in containing and redirecting the larger and heavier vehicle. Occupant risks are of foremost concern in the evaluation of the test. The tests presented herein, 448523-1 and 409260-1, are *NCHRP Report 350* test designation 3-11.

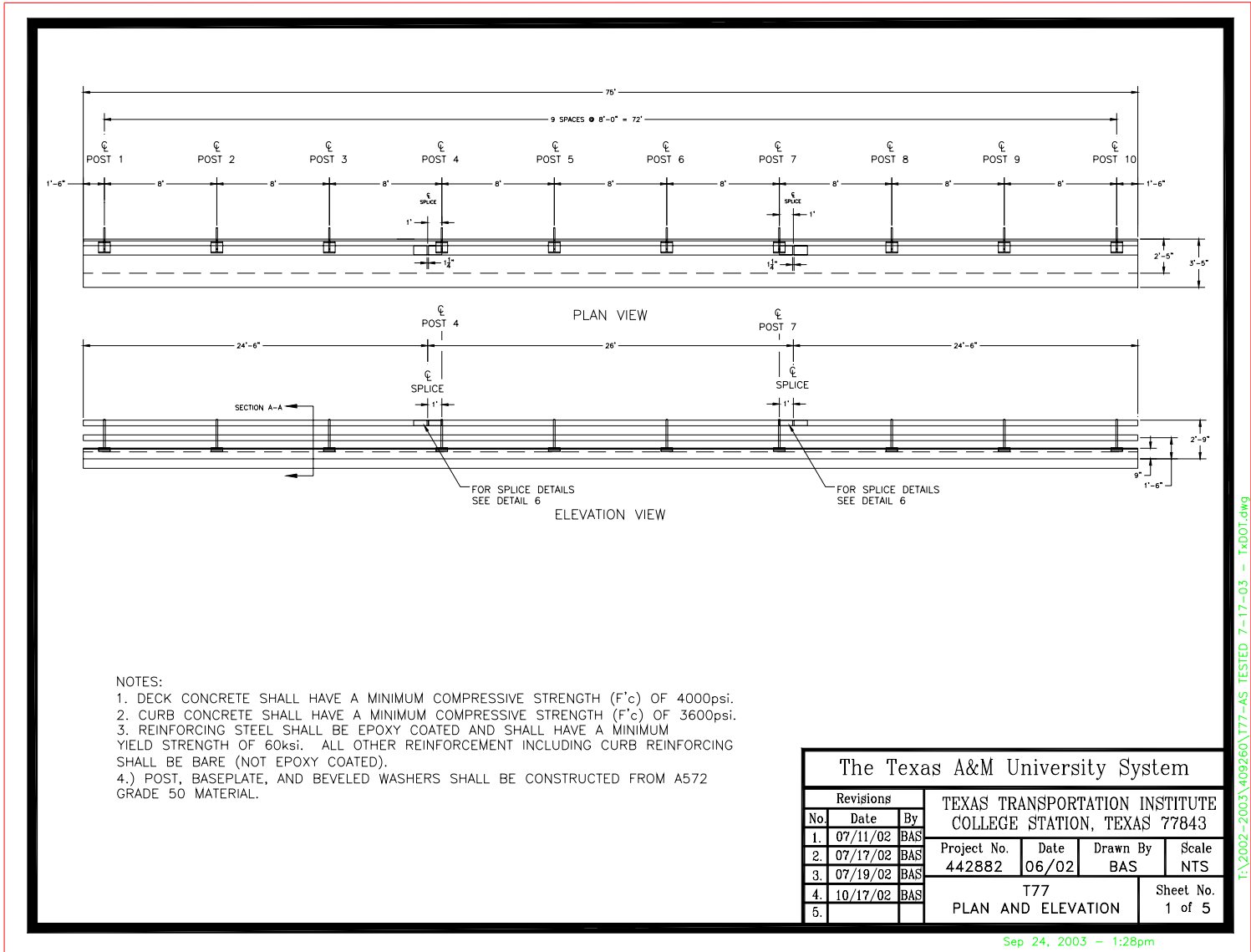

Figure 1. Details of the Layout of the Modified T77 Bridge Rail.

I:\2002-2003\409260\T77-AS TESTED 7-17-03 - TxDOT.dwg

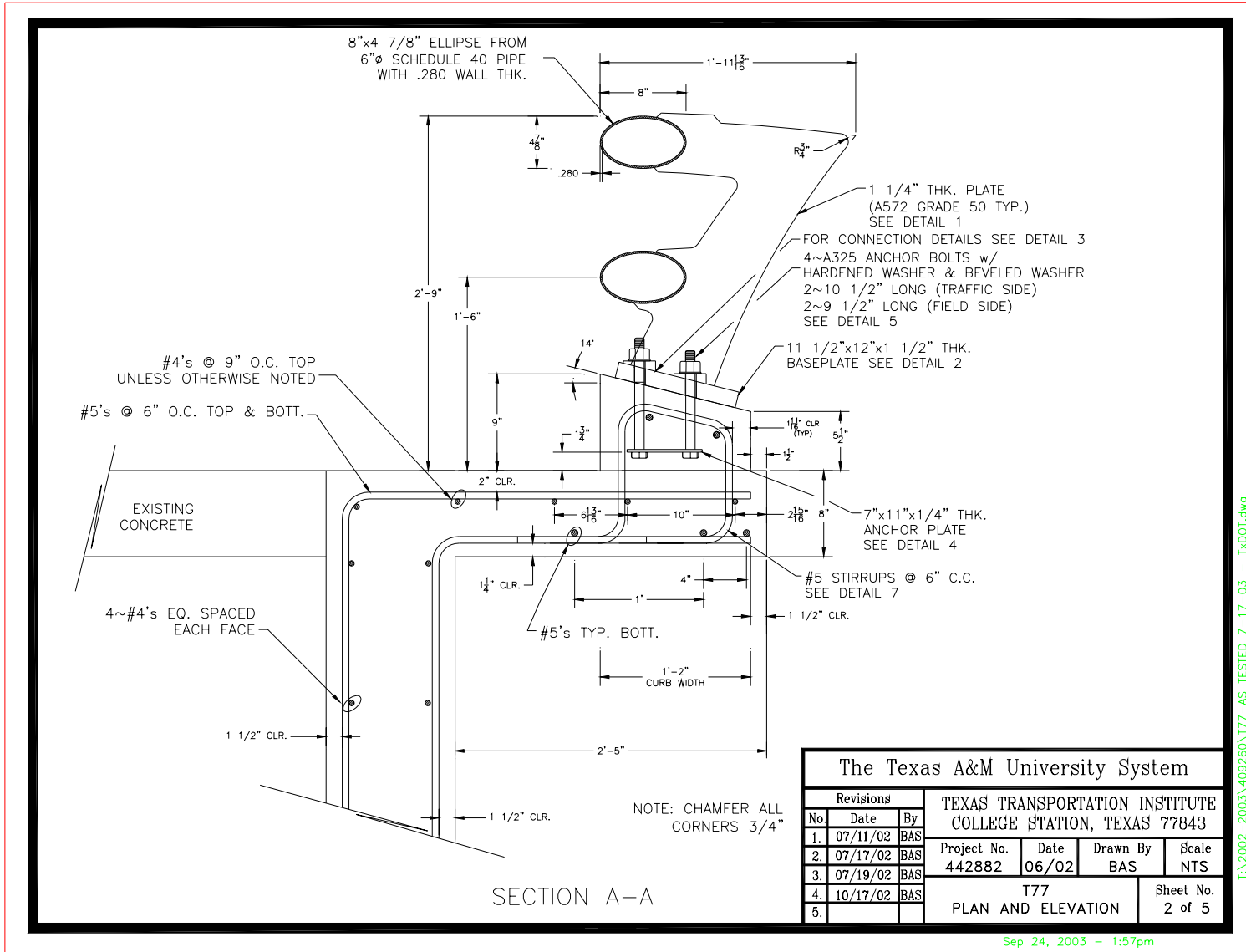

Figure 2. Cross Section of the Modified T77 Bridge Rail.

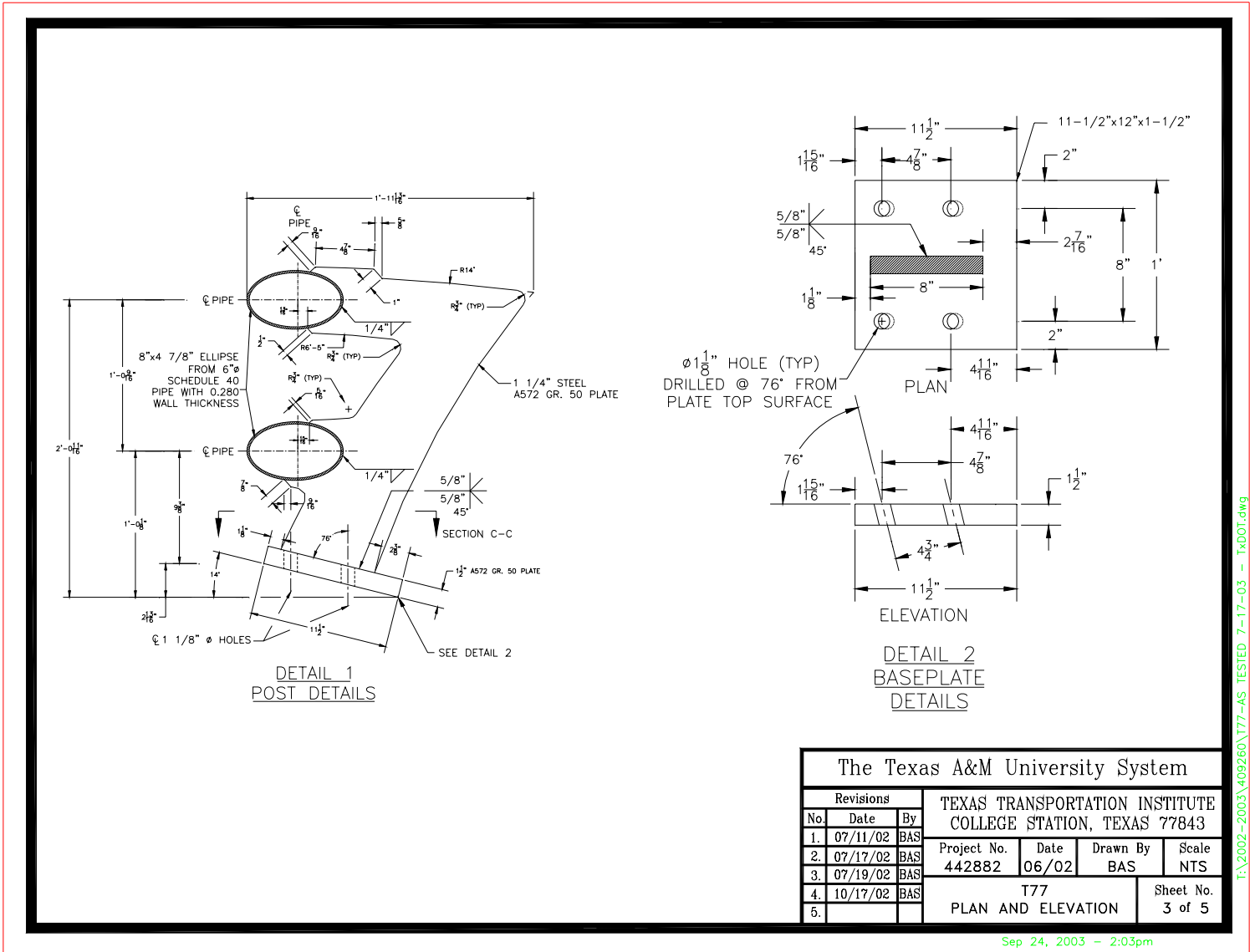

Figure 3. Post and Baseplate Details of the Modified T77 Bridge Rail.

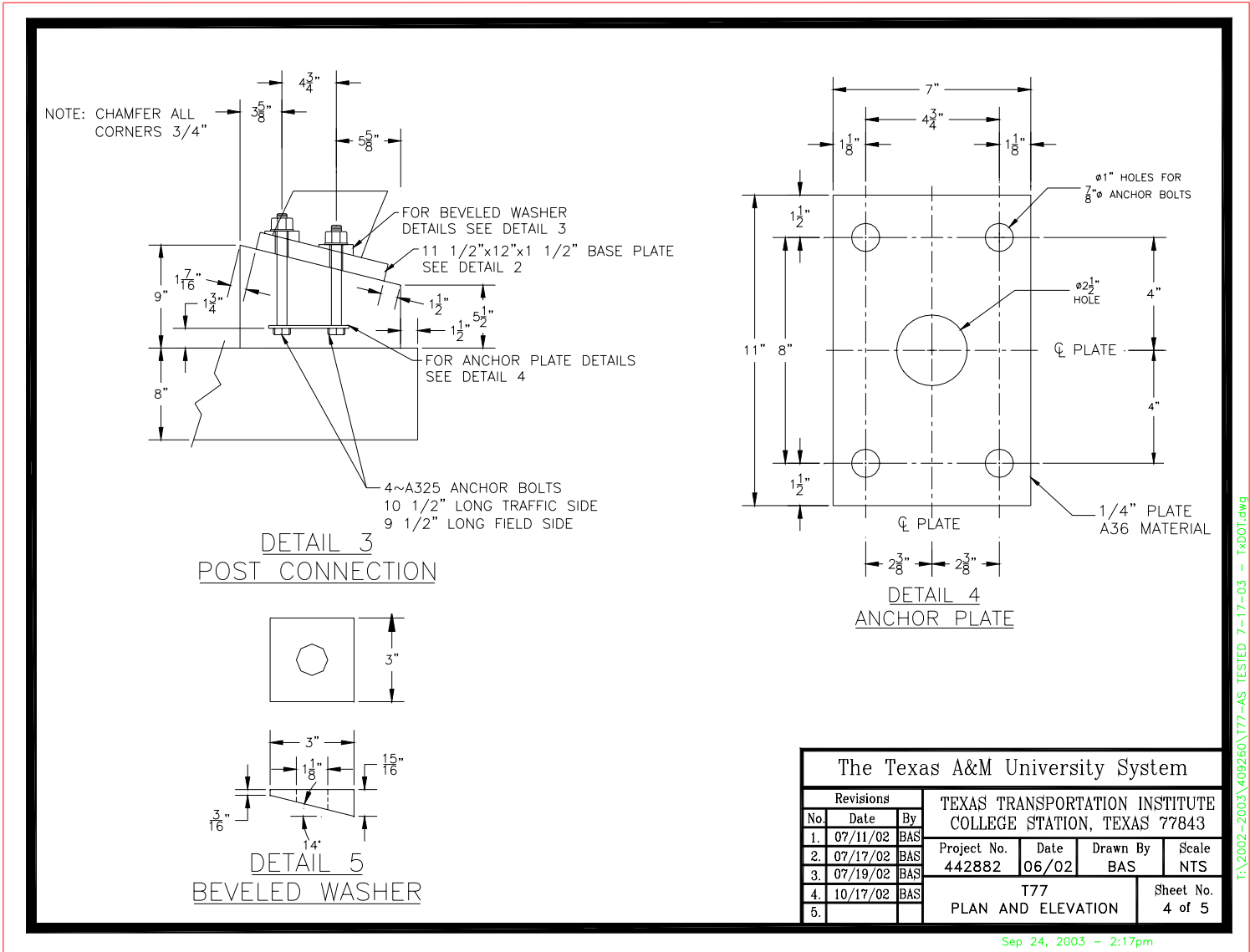
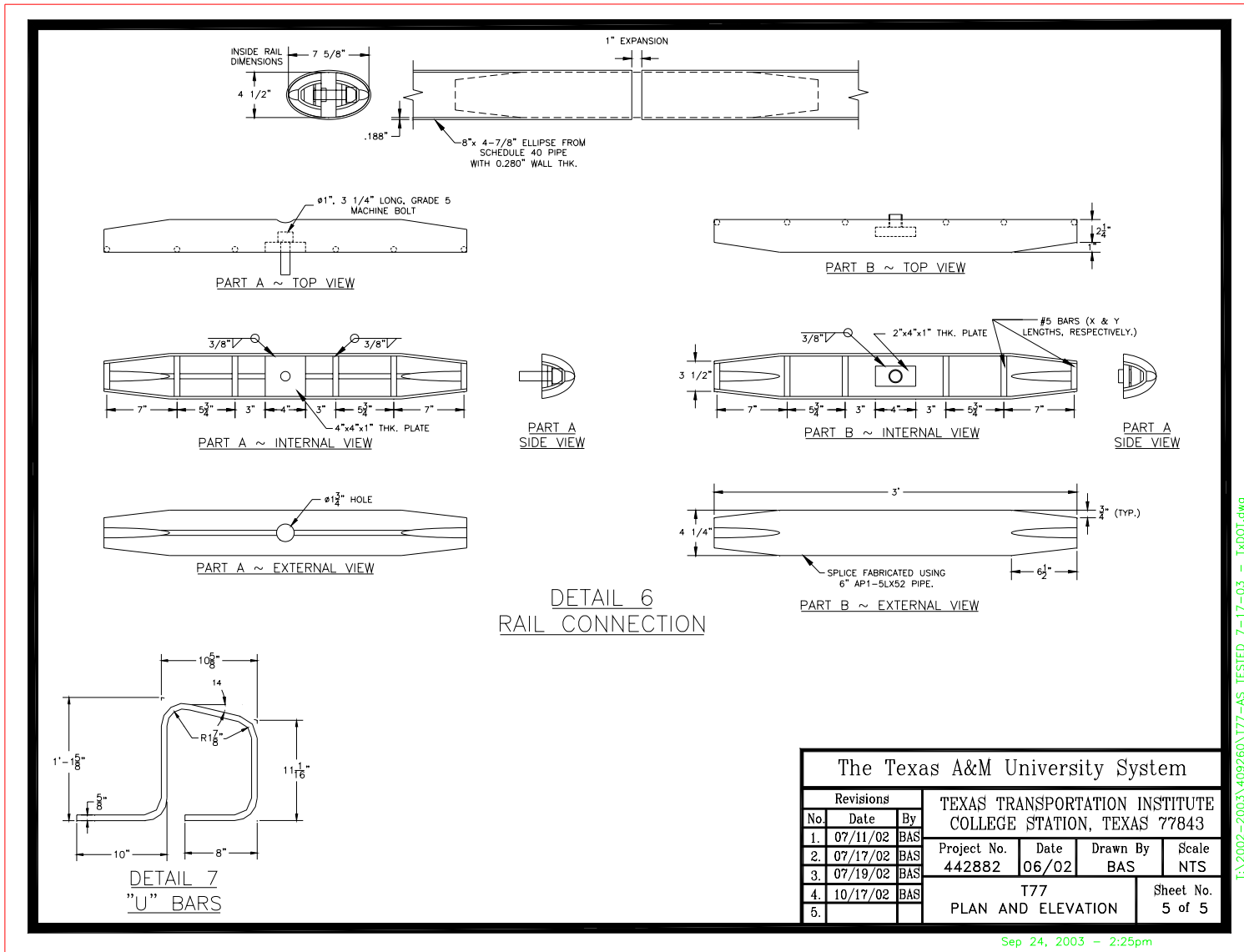

Figure 4. Post and Baseplate Connection Details of the Modified T77 Bridge Rail.



The Texas A&M University System			
TEXAS TRANSPORTATION INSTITUTE COLLEGE STATION, TEXAS 77843			
Revisions		Project No.	Date
No.	Date	By	Scale
1.	07/11/02	BAS	NTS
2.	07/17/02	BAS	
3.	07/19/02	BAS	
4.	10/17/02	BAS	
5.			
T77		Sheet No.	
PLAN AND ELEVATION		5 of 5	

Sep 24, 2003 - 2:25pm

I:\2002-2003\409260\T77-AS TESTED 7-17-03 - TxDOT.dwg

Figure 5. Rail Connection Details of the Modified T77 Bridge Rail.



Figure 6. Modified T77 Bridge Rail Before Test 448523-1.

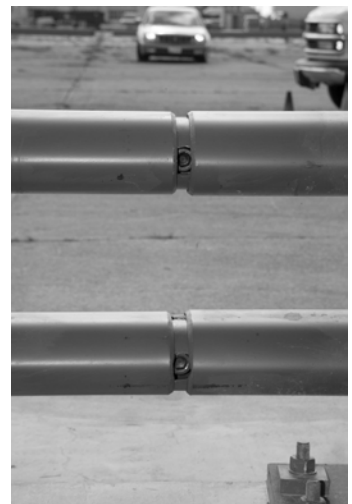
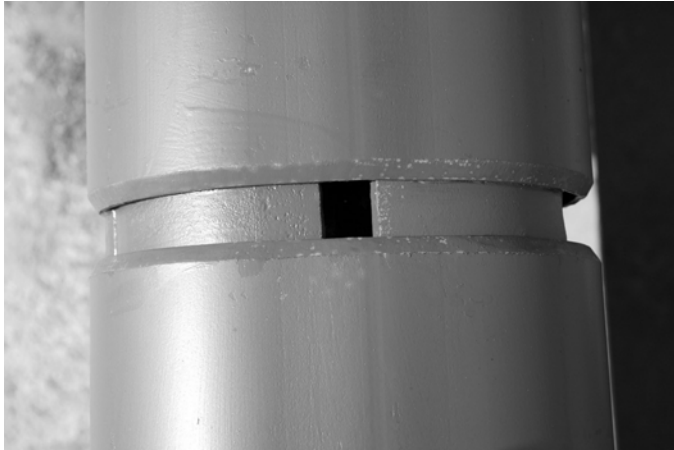

Figure 7. Modified T77 Bridge Rail Before Test 409260-1.

The crash test and data analysis procedures were in accordance with guidelines presented in *NCHRP Report 350*. Appendix A presents brief descriptions of these procedures.

EVALUATION CRITERIA

The crash test performed was evaluated in accordance with *NCHRP Report 350*. As stated in *NCHRP Report 350*, “Safety performance of a highway appurtenance cannot be measured directly but can be judged on the basis of three factors: structural adequacy, occupant risk, and vehicle trajectory after collision.” Accordingly, researchers used the safety evaluation criteria from Table 5.1 of *NCHRP Report 350* to evaluate the crash test reported herein.

CHAPTER 3. CRASH TEST RESULTS

TEST NO. 448523-1 (NCHRP Report 350 TEST NO. 3-11)

Test Vehicle

A 1999 Chevrolet Cheyenne 2500 pickup truck, shown in Figures 8 and 9, was used for the crash test. Test inertia weight of the vehicle was 4551 lb (2066 kg), and its gross static weight was 4551 lb (2066 kg). The height to the lower edge of the vehicle bumper was 16.3 inches (415 mm), and it was 25.0 inches (635 mm) to the upper edge of the bumper. Appendix B, Figure 22, give additional dimensions and information on the vehicle. The vehicle was directed into the installation using the cable reverse tow and guidance system and was released to be free-wheeling and unrestrained just prior to impact.

Soil and Weather Conditions

The test was performed on the morning of May 27, 2003. No rainfall was recorded during the 10 days prior to the test. Weather conditions at the time of testing were as follows: wind speed: 8 mph (13 km/h); wind direction: 100 degrees with respect to the vehicle (vehicle was traveling in a northwesterly direction); temperature: 75 °F (24 °C); relative humidity: 73 percent.

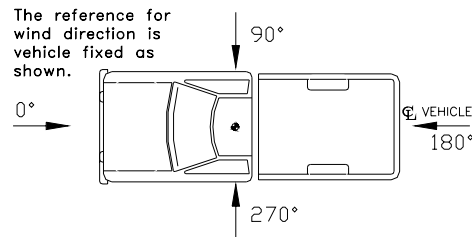

Test Description

The vehicle, traveling at 62.5 mph (100.6 km/h), impacted the T77 bridge rail 4.0 ft (1.2 m) upstream of post 7 at an impact angle of 24.6 degrees. Shortly after impact, the left front tire contacted the curb, and at 0.020 s, post 7 began to deflect toward the field side. The left front tire contacted the rail element at 0.022 s, and the tire blew out at 0.030 s. At 0.042 s, the front bumper contacted post 7, and at 0.050 s, the vehicle began to redirect. The left front wheel rim snagged on the lower splice at 0.062 s. The left rear tire contacted the curb at 0.203 s, and the tire blew out at 0.213 s. At 0.219 s, the vehicle was traveling parallel with the rail at a speed of 48.7 mph (78.4 km/h). The left front of the vehicle lost contact with the rail at 0.265 s. At 0.585 s, the vehicle lost contact with the bridge rail and was traveling at a speed of 46.4 mph (74.7 km/h) and an exit angle of 15.0 degrees. Brakes on the vehicle were applied at 3.65 s after impact. The vehicle subsequently yawed counterclockwise and came to rest 243.8 ft (74.3 m) downstream of impact and 62.5 ft (1.91 m) forward of the traffic face of the rail. Appendix C, Figures 24 and 25, show sequential photographs of the test period.



Figure 8. Vehicle/Installation Geometrics for Test 448523-1.



Figure 9. Vehicle Before Test 448523-1.

Damage to Test Installation

Figures 10 and 11 show damage to the T77 bridge rail. The lower rail element had a 0.8 inch (21 mm) deep indentation in the traffic face. Cracks radiated out of the front and rear anchor bolts of post 7 and extended toward and down the rear side of the curb and into the deck. The traffic face of the curb was also fractured below the baseplate of post 7. Total length of contact of the vehicle with the bridge rail was 16.7 ft (5.1 m). Maximum dynamic deflection of the rail element was 1.1 inches (28 mm), and maximum permanent deformation was 0.8 inch (21 mm).

Vehicle Damage

Figure 12 shows damage to the vehicle. Structural damage was imparted to the left upper and lower A-arms, left outer tie rod end, left upper ball joint, floor pan, and left frame rail. Also damaged were the front bumper, hood, grill, radiator, fan, left front quarter panel, left door, left rear exterior bed, left rear tire and wheel rim, and rear bumper. The tire and outer rim separated from the inner rim of the left front wheel. Part of the leading edge of the wheel rim was torn off and left embedded in the rail splice joint. The windshield sustained stress fractures, and the instrument panel was deformed. Maximum exterior crush to the vehicle was 21.3 inches (540 mm) on the side plane at the left front corner at bumper height. Maximum occupant compartment deformation was 6.9 inches (174 mm) in the lateral area of the kick panel on the left side. Photographs of the interior of the vehicle are shown in Figure 13. Exterior crush and occupant compartment deformations are given in Appendix B, Tables 3 and 4.

Occupant Risk Factors

Data from the triaxial accelerometer, located at the vehicle center of gravity, were digitized to compute occupant impact velocity and ridedown accelerations. Only the occupant impact velocity and ridedown accelerations in the longitudinal axis are required from these data for evaluation of criterion L of *NCHRP Report 350*. In the longitudinal direction, occupant impact velocity was 21.3 ft/s (6.5 m/s) at 0.099 s, maximum 0.010-s ridedown acceleration was -4.3 g's from 0.099 to 0.109 s, and the maximum 0.050-s average was -10.4 g's between 0.062 and 0.112 s. In the lateral direction, the occupant impact velocity was 24.6 ft/s (7.5 m/s) at 0.099 s, the highest 0.010-s occupant ridedown acceleration was 10.4 g's from 0.245 to 0.255 s, and the maximum 0.050-s average was 11.9 g's between 0.017 and 0.067 s. These data and other information pertinent to the test are presented in Figure 14. Vehicle angular displacements and accelerations versus time traces are shown in Appendix D, Figures 28 through 34.



Figure 10. After Impact Trajectory Path for Test 448523-1.

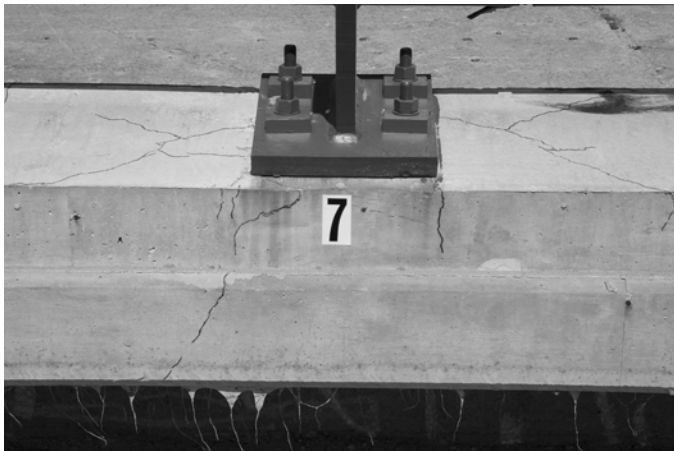
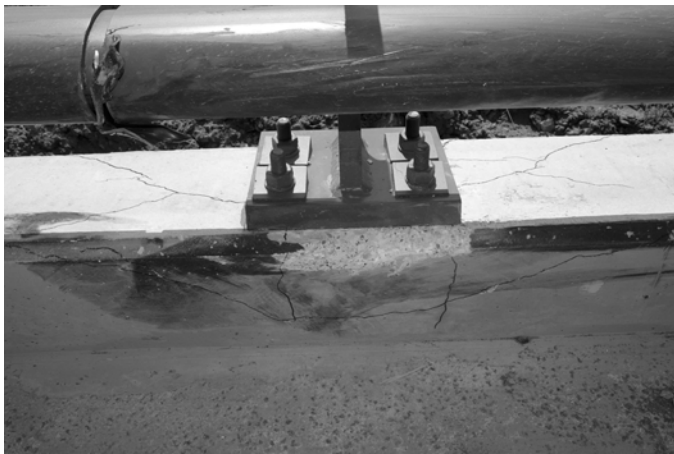

Figure 11. Installation After Test 448523-1.



Figure 12. Vehicle After Test 448523-1.



Before Test



After Test

Figure 13. Interior of Vehicle for Test 448523-1.

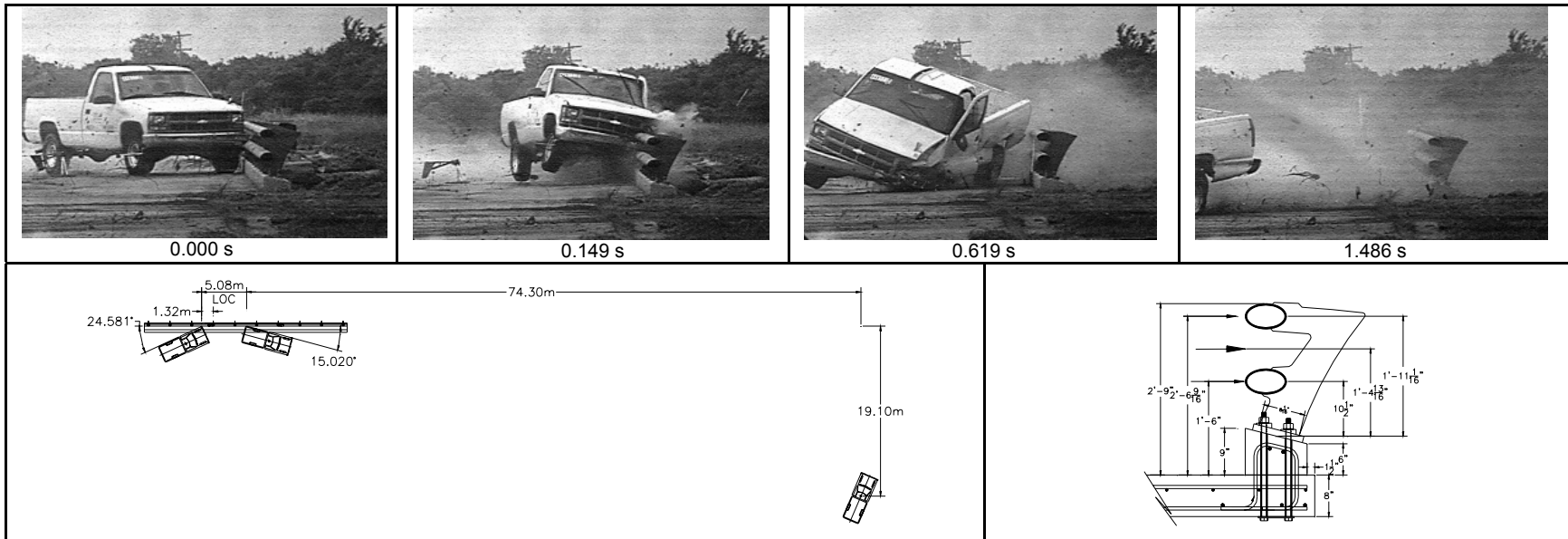

General Information		Impact Conditions		Test Article Deflections (in)	
Test Agency	Texas Transportation Institute	Speed (mi/h)	62.5 (100.6 km/h)	Dynamic	1.1 (28 mm)
Test No.	448523-1	Angle (deg)	24.6	Permanent	0.8 (21 mm)
Date	05/27/03	Exit Conditions		Working Width	24.9 (638 mm)
Test Article		Speed (mi/h)	46.4 (74.7 km/h)	Vehicle Damage	
Type	Bridge Rail	Angle (deg)	15.0	Exterior	
Name	Modified T77 Bridge Rail	Occupant Risk Values		VDS	
Installation Length (ft)	75 (22.7 m)	Impact Velocity (ft/s)		CDC	
Material or Key Elements	Steel Elliptical Rails And Steel '7'-Shaped Posts	x-direction	21.3 (6.5 m/s)	Maximum Exterior	
Soil Type and Condition	Concrete Footing, Dry	y-direction	24.6 (7.5 m/s)	Vehicle Crush (in)	
Test Vehicle		THIV (mi/h)	21.5 (34.7 km/h)	Interior	
Type	Production	Ridedown Accelerations (g's)		OCDI	
Designation	2000P	x-direction	-4.3	Max. Occ. Compartment	
Model	1999 Chevrolet Cheyenne 2500 Pickup	y-direction	10.4	Deformation (in)	
Mass (lb)		PHD (g's)	10.6	Post-Impact Behavior	
Curb	4692 (2131 kg)	ASI	1.56	(during 1.0 s after impact)	
Test Inertial	4551 (2066 kg)	Max. 0.050-s Average (g's)		Max. Yaw Angle (deg)	
Dummy	N/A	x-direction	-10.4	Max. Pitch Angle (deg)	
Gross Static	4551 (2066 kg)	y-direction	11.9	Max. Roll Angle (deg)	
		z-direction	6.6		

Figure 14. Summary of Results for Test 448523-1, NCHRP Report 350 Test 3-11.

Assessment of Test Results

An assessment of the test based on the applicable *NCHRP Report 350* safety evaluation criteria is provided below.

Structural Adequacy

- A. *Test article should contain and redirect the vehicle; the vehicle should not penetrate, underride, or override the installation although controlled lateral deflection of the test article is acceptable.*

Results: The T77 bridge rail contained and redirected the 2000P pickup truck. The 2000P pickup truck did not penetrate, underride, or override the installation. Maximum dynamic deflection during the test was 0.8 inch (21 mm). (PASS)

Occupant Risk

- D. *Detached elements, fragments, or other debris from the test article should not penetrate or show potential for penetrating the occupant compartment, or present an undue hazard to other traffic, pedestrians, or personnel in a work zone. Deformation of, or intrusions into, the occupant compartment that could cause serious injuries should not be permitted.*

Results: No detached elements, fragments, or other debris were present to penetrate or to show potential for penetrating the occupant compartment, or to present undue hazard to others in the area. Maximum occupant compartment deformation was 6.9 inches (174 mm) in the left kick panel laterally across the cab. (FAIL)

- F. *The vehicle should remain upright during and after collision although moderate roll, pitching, and yawing are acceptable.*

Results: The vehicle remained upright during and after the collision event. (PASS)

Vehicle Trajectory

- K. *After collision, it is preferable that the vehicle's trajectory not intrude into adjacent traffic lanes.*

Results: The vehicle yawed counterclockwise and came to rest 243.8 ft (74.3 m) downstream of impact and 62.5 ft (1.9 m) forward of the traffic face of the rail after the brakes were set. (FAIL)

- L. *The occupant impact velocity in the longitudinal direction should not exceed 12 m/s and the occupant ridedown acceleration in the longitudinal direction should not exceed 20 g's.*

- 3. Device Damage
 - a. None
 - b. Superficial
 - c. Substantial, but can be straightened
 - d. Substantial, replacement parts needed for repair
 - e. Cannot be repaired

TEST NO. 409260-1 (NCHRP Report 350 TEST NO. 3-11)

Test Vehicle

A 2000 Chevrolet Cheyenne 2500 pickup truck, shown in Figures 15 and 16, was used for the crash test. Test inertia weight of the vehicle was 4515 lb (2050 kg), and its gross static weight was 4515 lb (2050 kg). The height to the lower edge of the vehicle bumper was 16.3 inches (415 mm), and it was 25.0 inches (635 mm) to the upper edge of the bumper. Additional dimensions and information on the vehicle are given in Appendix B, Figure 23. The vehicle was directed into the installation using the cable reverse tow and guidance system and was released to be free-wheeling and unrestrained just prior to impact.

Soil and Weather Conditions

The test was performed on the morning of July 17, 2003. Rainfall of 0.13 inch (3 mm) and 0.14 inch (4 mm) was recorded six and 10 days prior to the test, respectively. Weather conditions at the time of testing were as follows: wind speed: 3 mi/h (2 km/h); wind direction: 350 degrees with respect to the vehicle (vehicle was traveling in a northwesterly direction); temperature: 88 °F (31 °C); relative humidity: 70 percent.

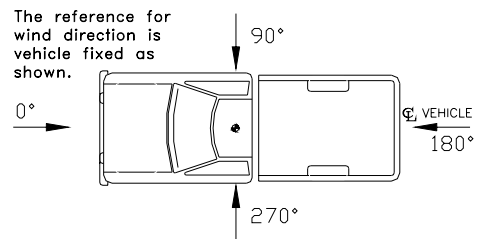

Test Description

The vehicle, traveling at 62.1 mph (99.9 km/h), impacted the T77 bridge rail 4.2 ft (1.3 m) upstream of post 4 at an impact angle of 25.1 degrees. Shortly after impact, the right front tire contacted the curb, and at 0.012 s, the front bumper protruded between the upper and lower rail elements. Post 4 began to deflect toward the field side at 0.017 s, and the right front tire blew out at 0.035 s. At 0.040 s, the front bumper contacted post 4, and at 0.047 s, the vehicle began to redirect. At 0.184 s, the vehicle was traveling parallel with the rail at a speed of 55.5 mph (89.3 km/h). The rear of the vehicle contacted the rail at 0.182 s, and the right front of the vehicle lost contact with the rail at 0.197 s. At 0.299 s, the vehicle lost contact with the bridge rail and was traveling at a speed of 55.1 mph (88.6 km/h) and an exit angle of 5.2 degrees. Brakes on the vehicle were applied 1.2 s after impact. The vehicle subsequently yawed clockwise and came to rest 217.5 ft (66.3 m) downstream of impact and 25.0 ft (7.6 m) forward of the traffic face of the rail. Appendix C, Figures 26 and 27, show sequential photographs of the test period.



Figure 15. Vehicle/Installation Geometrics for Test 409260-1.



Figure 16. Vehicle Before Test 409260-1.

Damage to Test Installation

Damage to the T77 bridge rail is shown in Figures 17 and 18. Cracks radiated out of the front and rear anchor bolts of post 3 and 4 and extended toward and down the rear side of the curb and into the deck. The traffic face of the curb was also fractured below the baseplate of post 4. Total length of contact of the vehicle with the bridge rail was 12.4 ft (3.8 m). Maximum dynamic deflection of the rail element was not attainable and maximum permanent deformation was 0.7 inch (18 mm).

Vehicle Damage

Damage to the vehicle is shown in Figure 19. Structural damage was imparted to the right upper and lower A-arms, floor pan, and right frame rail. Also damaged were the front bumper, hood, grill, radiator, fan, right front quarter panel, right front tire and wheel rim, right door, right rear exterior bed, right rear tire and wheel rim, and rear bumper. Maximum exterior crush to the vehicle was 17.7 inches (450 mm) on the frontal plane at the right front corner at bumper height. Maximum occupant compartment deformation was 3.0 inches (76 mm) in the center front floor pan area over the transmission tunnel and in the lateral area of the kick panel on the right side. Photographs of the interior of the vehicle are shown in Figure 20. Exterior crush and occupant compartment deformations are given in Appendix B, Tables 5 and 6.

Occupant Risk Factors

Data from the triaxial accelerometer, located at the vehicle center of gravity, were digitized to compute occupant impact velocity and ridedown accelerations. Only the occupant impact velocity and ridedown accelerations in the longitudinal axis are required from these data for evaluation of criterion L of *NCHRP Report 350*. In the longitudinal direction, occupant impact velocity was 18.0 ft/s (5.5 m/s) at 0.098 s, maximum 0.010-s ridedown acceleration was -3.7 g's from 0.208 to 0.218 s, and the maximum 0.050-s average was -8.4 g's between 0.035 and 0.085 s. In the lateral direction, the occupant impact velocity was 23.3 ft/s (7.1 m/s) at 0.098 s, the highest 0.010-s occupant ridedown acceleration was -9.2 g's from 0.221 to 0.231 s, and the maximum 0.050-s average was -10.4 g's between 0.045 and 0.095 s. These data and other information pertinent to the test are presented in Figure 21. Appendix D, Figures 35 through 41, show vehicle angular displacements and acceleration versus time traces.



Figure 17. After Impact Trajectory Path for Test 409260-1.



Figure 18. Installation After Test 409260-1.



Figure 18. Installation After Test 409260-1 (Continued).



Figure 19. Vehicle After Test 409260-1.



Before Test

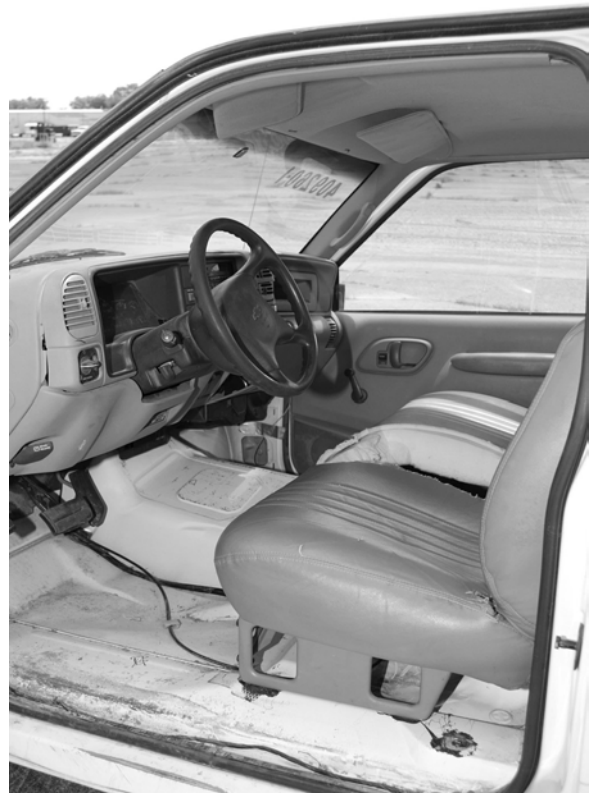

After Test



Figure 20. Interior of Vehicle for Test 409260-1.

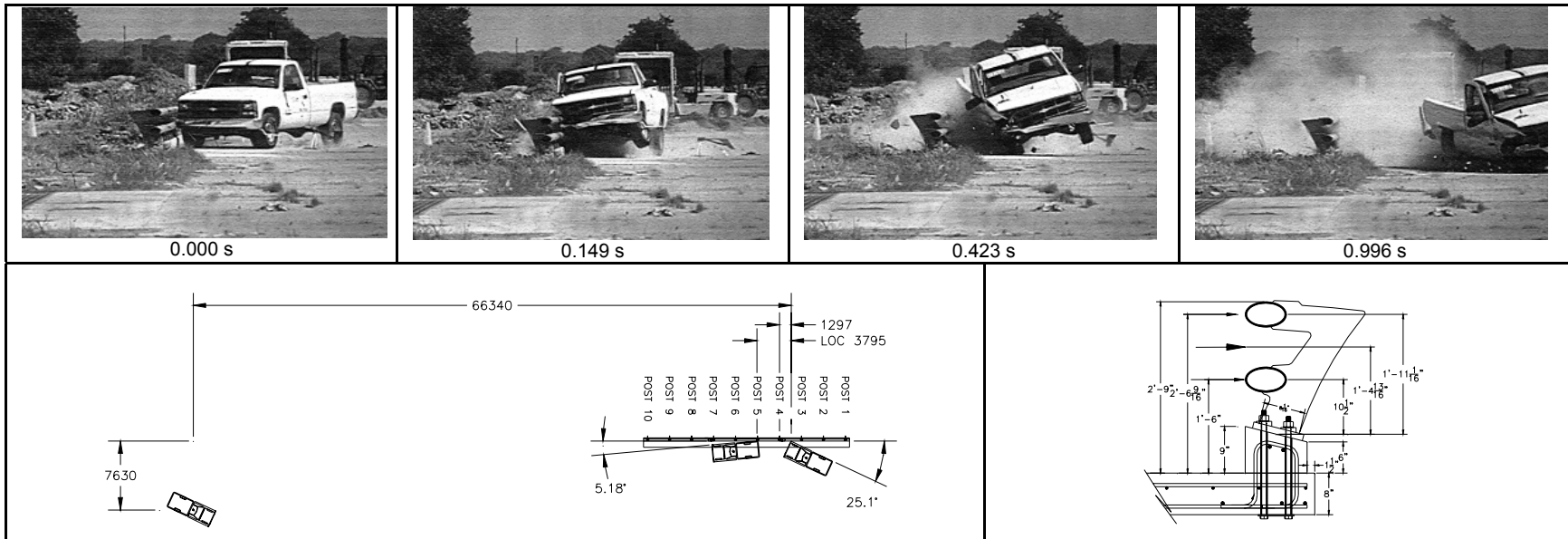

General Information		Impact Conditions		Test Article Deflections (in)	
Test Agency	Texas Transportation Institute	Speed (mi/h)	62.1 (99.9 km/h)	Dynamic	Not attainable
Test No.	409260-1	Angle (deg)	25.1	Permanent	0.7 (18 mm)
Date	07/17/03	Exit Conditions		Working Width	Not attainable
Test Article		Speed (mi/h)	55.1 (88.6 km/h)	Vehicle Damage	
Type	Bridge Rail	Angle (deg)	5.2	Exterior	
Name	Modified T77 Bridge Rail	Occupant Risk Values		VDS	01FR2
Installation Length (ft)	75 (22.7 m)	Impact Velocity (ft/s)		CDC	01FREW2
Material or Key Elements	Steel Elliptical Rails And Steel '7'-Shaped Posts	x-direction	18.0 (5.5 m/s)	Maximum Exterior	
Soil Type and Condition		y-direction	23.3 (7.1 m/s)	Vehicle Crush (in)	17.7 (450 mm)
Test Vehicle		THIV (mi/h)	19.5 (31.4 km/h)	Interior	
Type	Production	Ridedown Accelerations (g's)		OCDI	RF0103000
Designation	2000P	x-direction	-3.7	Max. Occ. Compartment	
Model	2000 Chevrolet Cheyenne 2500 Pickup	y-direction	-9.2	Deformation (in)	3.0 (76 mm)
Mass (lb)		PHD (g's)	9.3	Post-Impact Behavior	
Curb	4752 (2158 kg)	ASI	1.43	(during 1.0 s after impact)	
Test Inertial	4515 (2050 kg)	Max. 0.050-s Average (g's)		Max. Yaw Angle (deg)	-36.6
Dummy	N/A	x-direction	-8.4	Max. Pitch Angle (deg)	-8.8
Gross Static	4515 (2050 kg)	y-direction	-10.4	Max. Roll Angle (deg)	17.1
		z-direction	-5.4		

Figure 21. Summary of Results for Test 409260-1, NCHRP Report 350 Test 3-11.

Assessment of Test Results

An assessment of the test based on the applicable NCHRP Report 350 safety evaluation criteria is provided below.

Structural Adequacy

- A. *Test article should contain and redirect the vehicle; the vehicle should not penetrate, underride, or override the installation although controlled lateral deflection of the test article is acceptable.*

Results: The T77 bridge rail contained and redirected the 2000P pickup truck. The 2000P pickup truck did not penetrate, underride, or override the installation. Maximum permanent deformation after the test was 0.7 inch (18 mm). (PASS)

Occupant Risk

- D. *Detached elements, fragments, or other debris from the test article should not penetrate or show potential for penetrating the occupant compartment, or present an undue hazard to other traffic, pedestrians, or personnel in a work zone. Deformation of, or intrusions into, the occupant compartment that could cause serious injuries should not be permitted.*

Results: No detached elements, fragments, or other debris were present to penetrate or to show potential for penetrating the occupant compartment, or to present undue hazard to others in the area. Maximum occupant compartment deformation was 3.0 inches (76 mm) in the center front floor pan area over the transmission tunnel and in the left kick panel laterally across the cab. (PASS)

- F. *The vehicle should remain upright during and after collision although moderate roll, pitching, and yawing are acceptable.*

Results: The vehicle remained upright during and after the collision event. (PASS)

Vehicle Trajectory

- K. *After collision, it is preferable that the vehicle's trajectory not intrude into adjacent traffic lanes.*

Results: The vehicle yawed clockwise and came to rest 217.5 ft (66.3 m) downstream of impact and 25.0 ft (7.6 m) forward of the traffic face of the rail after the brakes were set. (FAIL)

- L. *The occupant impact velocity in the longitudinal direction should not exceed 12 m/s and the occupant ridedown acceleration in the longitudinal direction should not exceed 20 g's.*

Results: Longitudinal occupant impact velocity was 18.0 ft/s (5.5 m/s), and longitudinal ridedown acceleration was -3.7 g's. (PASS)

M. The exit angle from the test article preferably should be less than 60 percent of the test impact angle, measured at time of vehicle loss of contact with the test device.

Results: Exit angle at loss of contact was 5.2 degrees, which was 21 percent of the impact angle. (PASS)

The following supplemental evaluation factors and terminology, as presented in the FHWA memo entitled "Action: Identifying Acceptable Highway Safety Features," were used for visual assessment of test results:

Passenger Compartment Intrusion

- 1. Windshield Intrusion
 - a. No windshield contact
 - b. Windshield contact, no damage
 - c. Windshield contact, no intrusion
 - d. Device embedded in windshield, no significant intrusion
 - e. Complete intrusion into passenger compartment
 - f. Partial intrusion into passenger compartment
- 2. Body Panel Intrusion yes or no

Loss of Vehicle Control

- 1. Physical loss of control
- 2. Loss of windshield visibility
- 3. Perceived threat to other vehicles
- 4. Debris on pavement

Physical Threat to Workers or Other Vehicles

- 1. Harmful debris that could injure workers or others in the area
 - 2. Harmful debris that could injure occupants in other vehicles
- No debris was present.

Vehicle and Device Condition

- 1. Vehicle Damage
 - a. None
 - b. Minor scrapes, scratches, or dents
 - c. Significant cosmetic dents
 - d. Major dents to grill and body panels
 - e. Major structural damage
- 2. Windshield Damage
 - a. None
 - b. Minor chip or crack
 - c. Broken, no interference with visibility
 - d. Broken or shattered, visibility restricted but remained intact
 - e. Shattered, remained intact but partially dislodged
 - f. Large portion removed
 - g. Completely removed

- 3. Device Damage
 - a. None
 - b. Superficial
 - c. Substantial, but can be straightened
 - d. Substantial, replacement parts needed for repair
 - e. Cannot be repaired

CHAPTER 4. SUMMARY AND CONCLUSIONS

SUMMARY OF TEST RESULTS

Test 448523-1

The T77 bridge rail contained and redirected the 2000P pickup truck. The 2000P pickup truck did not penetrate, underride, or override the installation. Maximum dynamic deflection during the test was 0.8 inches (21 mm). No detached elements, fragments, or other debris were present to penetrate or to show potential for penetrating the occupant compartment, or to present undue hazard to others in the area. Maximum occupant compartment deformation was 6.9 inch (174 mm) in the left kick panel laterally across the cab. The vehicle remained upright during and after the collision event. The brakes were set, and the vehicle yawed counterclockwise and came to rest 243.8 ft (74.3 m) downstream of impact and 62.5 ft (1.9 m) forward of the traffic face of the rail. Longitudinal occupant impact velocity was 21.3 ft/s (6.5 m/s), and longitudinal ridedown acceleration was -4.3 g's. Exit angle at loss of contact was 15.0 degrees, which was 61 percent of the impact angle.

Test 409260-1

The T77 bridge rail contained and redirected the 2000P pickup truck. The 2000P pickup truck did not penetrate, underride, or override the installation. Maximum permanent deformation after the test was 0.7 inch (18 mm). No detached elements, fragments, or other debris were present to penetrate or to show potential for penetrating the occupant compartment, or to present undue hazard to others in the area. Maximum occupant compartment deformation was 3.0 inches (76 mm) in the center front floor pan area over the transmission tunnel and in the left kick panel laterally across the cab. The vehicle remained upright during and after the collision event. The brakes were set, and the vehicle yawed clockwise and came to rest 217.5 ft (66.3 m) downstream of impact and 25.0 ft (7.6 m) forward of the traffic face of the rail. Longitudinal occupant impact velocity was 18.0 ft/s (5.5 m/s), and longitudinal ridedown acceleration was -3.7g's. Exit angle at loss of contact was 5.2 degrees, which was 21 percent of the impact angle.

CONCLUSIONS

Due to excessive occupant compartment deformation in test 448523-1, the T77 bridge rail did not meet the occupant risk criteria for *NCHRP Report 350* test 3-11, as shown in Table 1. However, after additional design modifications and repeating test *NCHRP Report 350* test 3-11, the T77 bridge rail performed acceptably in test 409260-1, as shown in Table 2.

Table 1. Performance Evaluation Summary for Test 448523-1, NCHRP Report 350 Test 3-11.

Test Agency: Texas Transportation Institute	Test No.: 448523-1	Test Date: 05/27/2003
NCHRP Report 350 Test 3-11 Evaluation Criteria	Test Results	Assessment
<u>Structural Adequacy</u>		
A. <i>Test article should contain and redirect the vehicle; the vehicle should not penetrate, underride, or override the installation although controlled lateral deflection of the test article is acceptable.</i>	The T77 bridge rail contained and redirected the 2000P pickup truck. The 2000P pickup truck did not penetrate, underride, or override the installation. Maximum dynamic deflection during the test was 1.1 inch (28 mm).	Pass
<u>Occupant Risk</u>		
D. <i>Detached elements, fragments or other debris from the test article should not penetrate or show potential for penetrating the occupant compartment, or present an undue hazard to other traffic, pedestrians, or personnel in a work zone. Deformations of, or intrusions into, the occupant compartment that could cause serious injuries should not be permitted.</i>	No detached elements, fragments, or other debris were present to penetrate or to show potential for penetrating the occupant compartment, or to present undue hazard to others in the area. Maximum occupant compartment deformation was 6.9 inch (174 mm) in the left kick panel area laterally across the cab.	Fail
F. <i>The vehicle should remain upright during and after collision although moderate roll, pitching, and yawing are acceptable.</i>	The vehicle remained upright during and after the collision event.	Pass
<u>Vehicle Trajectory</u>		
K. <i>After collision it is preferable that the vehicle's trajectory not intrude into adjacent traffic lanes.</i>	The vehicle came to rest upright 172.6 ft (52.6 m) downstream of impact and 6.2 ft (1.9 m) forward of the traffic face of the rail.	Pass*
L. <i>The occupant impact velocity in the longitudinal direction should not exceed 12 m/s and the occupant ridedown acceleration in the longitudinal direction should not exceed 20 g's.</i>	Longitudinal occupant impact velocity was 21.3 ft/s (6.5 m/s), and longitudinal ridedown acceleration was -4.3 g's.	Pass
M. <i>The exit angle from the test article preferably should be less than 60 percent of test impact angle, measured at time of vehicle loss of contact with test device.</i>	Exit angle at loss of contact was 15.0 degrees, which was 61 percent of the impact angle.	Fail *

*Criterion K and M are preferable, not required.

Table 2. Performance Evaluation Summary for Test 409260-1, NCHRP Report 350 Test 3-11.

Test Agency: Texas Transportation Institute	Test No.: 409260-1	Test Date: 07/17/2003
NCHRP Report 350 Test 3-11 Evaluation Criteria	Test Results	Assessment
<u>Structural Adequacy</u>		
A. <i>Test article should contain and redirect the vehicle; the vehicle should not penetrate, underride, or override the installation although controlled lateral deflection of the test article is acceptable.</i>	The T77 bridge rail contained and redirected the 2000P pickup truck. The 2000P pickup truck did not penetrate, underride, or override the installation. Maximum dynamic deflection during the test was 0.7 inch (18 mm).	Pass
<u>Occupant Risk</u>		
D. <i>Detached elements, fragments or other debris from the test article should not penetrate or show potential for penetrating the occupant compartment, or present an undue hazard to other traffic, pedestrians, or personnel in a work zone. Deformations of, or intrusions into, the occupant compartment that could cause serious injuries should not be permitted.</i>	No detached elements, fragments, or other debris were present to penetrate or to show potential for penetrating the occupant compartment, or to present undue hazard to others in the area. Maximum occupant compartment deformation was 3.0 inch (76 mm) in the center front floor pan area and in the right kick panel area laterally across the cab.	Pass
F. <i>The vehicle should remain upright during and after collision although moderate roll, pitching, and yawing are acceptable.</i>	The vehicle remained upright during and after the collision event.	Pass
<u>Vehicle Trajectory</u>		
K. <i>After collision it is preferable that the vehicle's trajectory not intrude into adjacent traffic lanes.</i>	The vehicle came to rest upright 217.5 ft (66.3 m) downstream of impact and 25.0 ft (7.6 m) forward of the traffic face of the rail.	Fail*
L. <i>The occupant impact velocity in the longitudinal direction should not exceed 12 m/s and the occupant ridedown acceleration in the longitudinal direction should not exceed 20 g's.</i>	Longitudinal occupant impact velocity was 18.0 ft/s (5.5 m/s), and longitudinal ridedown acceleration was -3.7 g's.	Pass
M. <i>The exit angle from the test article preferably should be less than 60 percent of test impact angle, measured at time of vehicle loss of contact with test device.</i>	Exit angle at loss of contact was 5.2 degrees, which was 21 percent of the impact angle.	Pass *

*Criterion K and M are preferable, not required.

CHAPTER 5. IMPLEMENTATION STATEMENT

The T77 bridge rail has been crash tested and successfully meets the safety performance evaluation criteria presented in *NCHRP Report 350* for Test Level 3 (62.2 mph [100 km/h]) longitudinal barriers. The T77 bridge rail is ready for implementation on Texas roadways and the National Highway System.

REFERENCES

1. H.E. Ross, Jr., D.L. Sicking, R.A. Zimmer and J.D. Michie, *Recommended Procedures for the Safety Performance Evaluation of Highway Features*, National Cooperative Highway Research Program Report 350, Transportation Research Board, National Research Council, Washington, D.C., 1993.
2. D. Lance Bullard, Jr., William Williams, Wanda L. Menges, and Rebecca R. Haug, *Design and Evaluation of the TxDOT F411 and T77 Aesthetic Bridge Rails*, Research Report 4288-1, Texas Transportation Institute, Texas A&M University System, College Station, TX, October 2002.

APPENDIX A. CRASH TEST PROCEDURES AND DATA ANALYSIS

The crash test and data analysis procedures were in accordance with guidelines presented in *NCHRP Report 350*. Brief descriptions of these procedures are presented as follows.

ELECTRONIC INSTRUMENTATION AND DATA PROCESSING

The test vehicle was instrumented with three solid-state angular rate transducers to measure roll, pitch, and yaw rates; a triaxial accelerometer near the vehicle center of gravity (c.g.) to measure longitudinal, lateral, and vertical acceleration levels; and a backup biaxial accelerometer in the rear of the vehicle to measure longitudinal and lateral acceleration levels. These accelerometers were Endevco Model 2262CA, piezoresistive accelerometers with a $\pm 100g$ range.

The accelerometers are strain gage type with a linear millivolt output proportional to acceleration. Angular rate transducers are solid state, gas flow units designed for high-“g” service. Signal conditioners and amplifiers in the test vehicle increase the low-level signals to a ± 2.5 volt maximum level. The signal conditioners also provide the capability of an R-cal (resistive calibration) or shunt calibration for the accelerometers and a precision voltage calibration for the rate transducers. The electronic signals from the accelerometers and rate transducers are transmitted to a base station by means of a 15-channel, constant bandwidth, Inter-Range Instrumentation Group (IRIG), FM/FM telemetry link for recording on magnetic tape and for display on a real-time strip chart. Calibration signals, from the test vehicle, are recorded before the test and immediately afterwards. A crystal-controlled time reference signal is simultaneously recorded with the data. Wooden dowels actuate pressure-sensitive switches on the bumper of the impacting vehicle prior to impact by wooden dowels to indicate the elapsed time over a known distance to provide a measurement of impact velocity. The initial contact also produces an “event” mark on the data record to establish the instant of contact with the installation.

The multiplex of data channels, transmitted on one radio frequency, is received and demultiplexed onto separate tracks of a 28-track, IRIG tape recorder. After the test, the data are played back from the tape machine and digitized. A proprietary software program (WinDigit) converts the analog data from each transducer into engineering units using the R-cal and pre-zero values at 10,000 samples per second, per channel. WinDigit also provides SAE J211 class 180 phaseless digital filtering and vehicle impact velocity.

All accelerometers are calibrated annually according to SAE J211 4.6.1 by means of an Endevco 2901, precision primary vibration standard. This device and its support instruments are returned to the factory annually for a National Institute of Standards Technology (NIST) traceable calibration. The subsystems of each data channel are also evaluated annually, using instruments with current NIST traceability, and the results are factored into the accuracy of the total data channel, per SAE J211. Calibrations and evaluations are made any time data are suspect.

The Test Risk Assessment Program (TRAP) uses the data from WinDigit to compute occupant/compartment impact velocities, time of occupant/compartment impact after vehicle

impact, and the highest 10-ms average ridedown acceleration. WinDigit calculates change in vehicle velocity at the end of a given impulse period. In addition, maximum average accelerations over 50-ms intervals in each of the three directions are computed. For reporting purposes, the data from the vehicle-mounted accelerometers are filtered with a 60-Hz digital filter, and acceleration versus time curves for the longitudinal, lateral, and vertical directions are plotted using TRAP.

TRAP uses the data from the yaw, pitch, and roll rate transducers to compute angular displacement in degrees at 0.0001-s intervals and then plots yaw, pitch, and roll versus time. These displacements are in reference to the vehicle-fixed coordinate system with the initial position and orientation of the vehicle-fixed coordinate systems being initial impact.

ANTHROPOMORPHIC DUMMY INSTRUMENTATION

Use of a dummy in the 2000P vehicle is optional according to *NCHRP Report 350*, and there was no dummy used in these tests.

PHOTOGRAPHIC INSTRUMENTATION AND DATA PROCESSING

Photographic coverage of the test included three high-speed cameras: one overhead with a field of view perpendicular to the ground and directly over the impact point; one placed behind the installation at an angle; and a third placed to have a field of view parallel to and aligned with the installation at the downstream end. A flash bulb activated by pressure-sensitive tape switches was positioned on the impacting vehicle to indicate the instant of contact with the installation and was visible from each camera. The films from these high-speed cameras were analyzed on a computer-linked Motion Analyzer to observe phenomena occurring during the collision and to obtain time-event, displacement, and angular data. A BetaCam, a VHS-format video camera and recorder, and still cameras recorded and documented conditions of the test vehicle and installation before and after the test.

TEST VEHICLE PROPULSION AND GUIDANCE

The test vehicle was towed into the test installation using a steel cable guidance and reverse tow system. A steel cable for guiding the test vehicle was tensioned along the path, anchored at each end, and threaded through an attachment to the front wheel of the test vehicle. An additional steel cable was connected to the test vehicle, passed around a pulley near the impact point, through a pulley on the tow vehicle, and then anchored to the ground such that the tow vehicle moved away from the test site. A two-to-one speed ratio between the test and tow vehicle existed with this system. Just prior to impact with the installation, the test vehicle was released to be free-wheeling and unrestrained. The vehicle remained free-wheeling, i.e., no steering or braking inputs, until the vehicle cleared the immediate area of the test site, at which time brakes on the vehicle were activated to bring it to a safe and controlled stop.

APPENDIX B. TEST VEHICLE PROPERTIES AND INFORMATION

DATE: 05/27/03 TEST NO.: 448523-1 VIN NO.: 1GCGC24R2XR702823
 YEAR: 1999 MAKE: Chevrolet MODEL: Cheyenne 2500
 TIRE INFLATION PRESSURE: _____ ODOMETER: 189951 TIRE SIZE: 245 75R16

MASS DISTRIBUTION (kg) LF 616 RF 589 LR 412 RR 449

DESCRIBE ANY DAMAGE TO VEHICLE PRIOR TO TEST:

● Denotes accelerometer location.

NOTES: _____

ENGINE TYPE: V-8
 ENGINE CID: 5.7 L
 TRANSMISSION TYPE:
 _____ AUTO
 MANUAL

OPTIONAL EQUIPMENT:
8 LUGS

DUMMY DATA:
 TYPE: _____
 MASS: _____
 SEAT POSITION: _____

GEOMETRY - (mm)

A	<u>1880</u>	E	<u>1310</u>	J	<u>1038</u>	N	<u>1590</u>	R	<u>750</u>
B	<u>810</u>	F	<u>5470</u>	K	<u>635</u>	O	<u>1610</u>	S	<u>900</u>
C	<u>3350</u>	G	<u>1396.1</u>	L	<u>70</u>	P	<u>725</u>	T	<u>1460</u>
D	<u>1820</u>	H	_____	M	<u>415</u>	Q	<u>440</u>	U	<u>3360</u>

MASS - (kg)	CURB	TEST INERTIAL	GROSS STATIC
M ₁	<u>1247</u>	<u>1205</u>	_____
M ₂	<u>884</u>	<u>861</u>	_____
M _T	<u>2131</u>	<u>2066</u>	_____

Figure 22. Vehicle Properties for Test 448523-1.

Table 3. Exterior Crush Measurements for Test 448523-1.

VEHICLE CRUSH MEASUREMENT SHEET¹

Complete When Applicable	
End Damage	Side Damage
Undeformed end width _____ Corner shift: A1 _____ A2 _____ End shift at frame (CDC) (check one) < 4 inches _____ ≥ 4 inches _____	Bowing: B1 _____ X1 _____ B2 _____ X2 _____ Bowing constant $\frac{X1 + X2}{2} = \underline{\hspace{2cm}}$

Note: Measure C₁ to C₆ from Driver to Passenger side in Front or Rear impacts – Rear to Front in Side Impacts.

Specific Impact Number	Plane* of C-Measurements	Direct Damage		Field L**	C ₁	C ₂	C ₃	C ₄	C ₅	C ₆	±D
		Width** (CDC)	Max*** Crush								
1	At front bumper	850	470	800	470	340	260	210	150	60	-400
2	At front bumper	850	540	1400	30	130	200	N/A	450	540	+1400

¹Table taken from National Accident Sampling System (NASS).

*Identify the plane at which the C-measurements are taken (e.g., at bumper, above bumper, at sill, above sill, at beltline, etc.) or label adjustments (e.g., free space).

Free space value is defined as the distance between the baseline and the original body contour taken at the individual C locations. This may include the following: bumper lead, bumper taper, side protrusion, side taper, etc. Record the value for each C-measurement and maximum crush.

**Measure and document on the vehicle diagram the beginning or end of the direct damage width and field L (e.g., side damage with respect to undamaged axle).

***Measure and document on the vehicle diagram the location of the maximum crush.

Note: Use as many lines/columns as necessary to describe each damage profile.

Table 4. Occupant Compartment Measurements for Test 448523-1.

Truck

Occupant Compartment Deformation

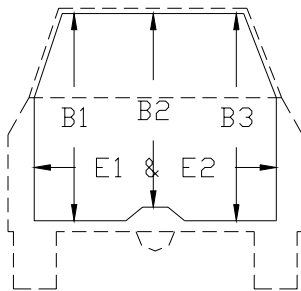
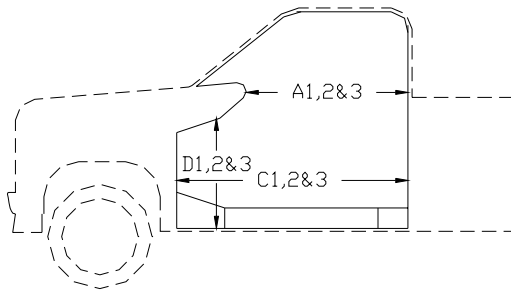
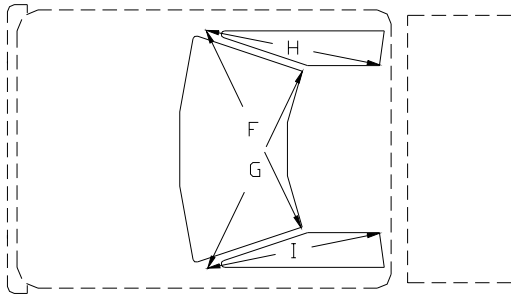

	BEFORE	AFTER
A1	870	825
A2	933	948
A3	936	955
B1	1080	1012
B2	1007	947
B3	1075	1065
C1	1370	1207
C2		
C3	1371	1371
D1	325	208
D2	155	160
D3	308	300
E1	1588	1575
E2	1592	1608
F	1460	1455
G	1460	1440
H	1250	1220
I	1250	1250
J	1522	1348

DATE: 07/17/03 TEST NO.: 409260-1 VIN NO.: 1GCGC24R5YR192100
 YEAR: 2000 MAKE: Chevrolet MODEL: Cheyenne 2500
 TIRE INFLATION PRESSURE: _____ ODOMETER: 167689 TIRE SIZE: 245 70R16

MASS DISTRIBUTION (kg) LF 593 RF 582 LR 436 RR 439

DESCRIBE ANY DAMAGE TO VEHICLE PRIOR TO TEST:

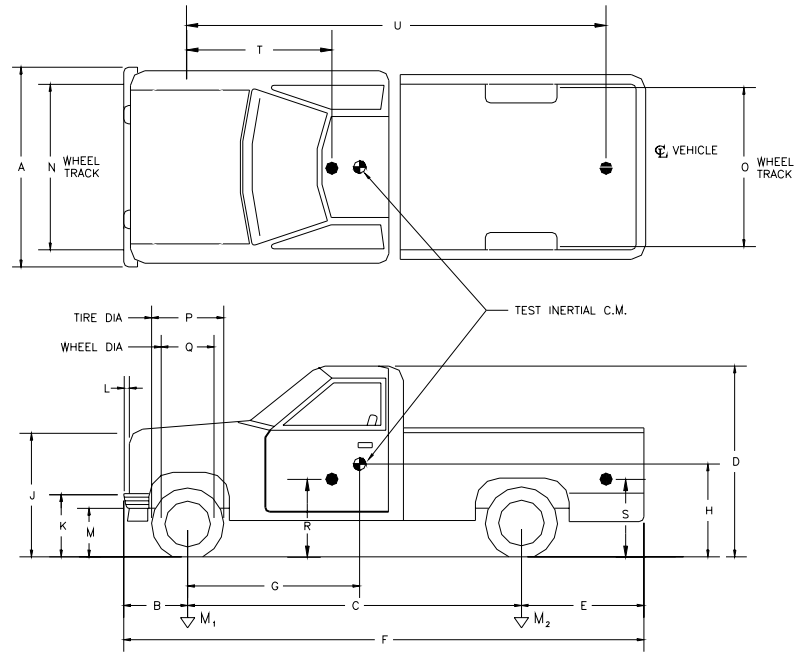

● Denotes accelerometer location.

NOTES: _____

ENGINE TYPE: V-8
 ENGINE CID: 5.7 L

TRANSMISSION TYPE:
 AUTO
 MANUAL

OPTIONAL EQUIPMENT:
8 LUGS

DUMMY DATA:
 TYPE: _____
 MASS: _____
 SEAT POSITION: _____

GEOMETRY - (mm)

A	<u>1880</u>	E	<u>1310</u>	J	<u>1038</u>	N	<u>1590</u>	R	<u>750</u>
B	<u>810</u>	F	<u>5470</u>	K	<u>635</u>	O	<u>1610</u>	S	<u>900</u>
C	<u>3350</u>	G	<u>1429.9</u>	L	<u>70</u>	P	<u>725</u>	T	<u>1460</u>
D	<u>1820</u>	H	_____	M	<u>415</u>	Q	<u>440</u>	U	<u>3360</u>

MASS - (kg)	CURB	TEST INERTIAL	GROSS STATIC
M ₁	<u>1222</u>	<u>1175</u>	_____
M ₂	<u>936</u>	<u>875</u>	_____
M _T	<u>2158</u>	<u>2050</u>	_____

Figure 23. Vehicle Properties for Test 409260-1.

Table 5. Exterior Crush Measurements for Test 409260-1.

VEHICLE CRUSH MEASUREMENT SHEET¹

Complete When Applicable	
End Damage	Side Damage
Undeformed end width _____ Corner shift: A1 _____ A2 _____ End shift at frame (CDC) (check one) < 4 inches _____ ≥ 4 inches _____	Bowing: B1 _____ X1 _____ B2 _____ X2 _____ Bowing constant $\frac{X1 + X2}{2} = \underline{\hspace{2cm}}$

Note: Measure C₁ to C₆ from Driver to Passenger side in Front or Rear impacts – Rear to Front in Side Impacts.

Specific Impact Number	Plane* of C-Measurements	Direct Damage		Field L**	C ₁	C ₂	C ₃	C ₄	C ₅	C ₆	±D
		Width** (CDC)	Max*** Crush								
1	At front bumper	900	450	1200	60	100	170	230	330	450	+390
2	Above front bumper	900	400	1400	50	140	Wheel Well		350	400	+1700

¹Table taken from National Accident Sampling System (NASS).

*Identify the plane at which the C-measurements are taken (e.g., at bumper, above bumper, at sill, above sill, at beltline, etc.) or label adjustments (e.g., free space).

Free space value is defined as the distance between the baseline and the original body contour taken at the individual C locations. This may include the following: bumper lead, bumper taper, side protrusion, side taper, etc. Record the value for each C-measurement and maximum crush.

**Measure and document on the vehicle diagram the beginning or end of the direct damage width and field L (e.g., side damage with respect to undamaged axle).

***Measure and document on the vehicle diagram the location of the maximum crush.

Note: Use as many lines/columns as necessary to describe each damage profile.

Table 6. Occupant Compartment Measurements for Test 409260-1.

T r u c k

O c c u p a n t C o m p a r t m e n t D e f o r m a t i o n

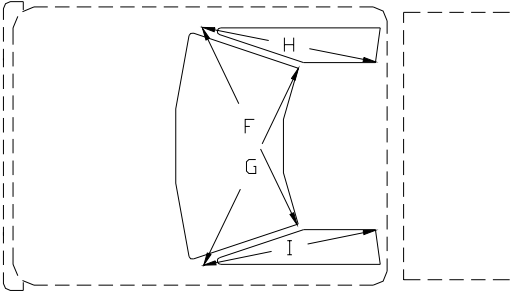
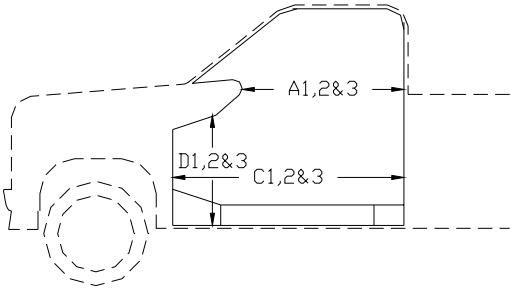
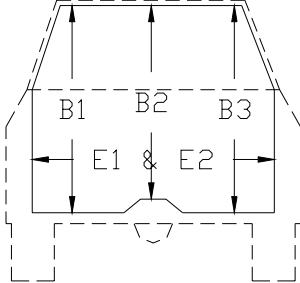
	BEFORE	AFTER
	<p>A1</p> <hr/> <p>A2</p> <hr/> <p>A3</p> <hr/> <p>B1</p> <hr/> <p>B2</p> <hr/> <p>B3</p> <hr/> <p>C1</p> <hr/> <p>C2</p> <hr/> <p>C3</p> <hr/> <p>D1</p> <hr/> <p>D2</p> <hr/> <p>D3</p> <hr/> <p>E1</p> <hr/> <p>E2</p> <hr/> <p>F</p> <hr/> <p>G</p> <hr/> <p>H</p> <hr/> <p>I</p> <hr/> <p>J</p> <hr/>	<p>860</p> <hr/> <p>920</p> <hr/> <p>931</p> <hr/> <p>1072</p> <hr/> <p>946</p> <hr/> <p>1069</p> <hr/> <p>1373</p> <hr/> <p>1373</p> <hr/> <p>1371</p> <hr/> <p>327</p> <hr/> <p>150</p> <hr/> <p>305</p> <hr/> <p>1585</p> <hr/> <p>1589</p> <hr/> <p>1465</p> <hr/> <p>1465</p> <hr/> <p>1260</p> <hr/> <p>1255</p> <hr/> <p>1521</p> <hr/>
		
		

APPENDIX C. SEQUENTIAL PHOTOGRAPHS



0.000 s



0.050 s



0.149 s



0.371 s



Figure 24. Sequential Photographs for Test 448523-1 (Overhead and Frontal Views).

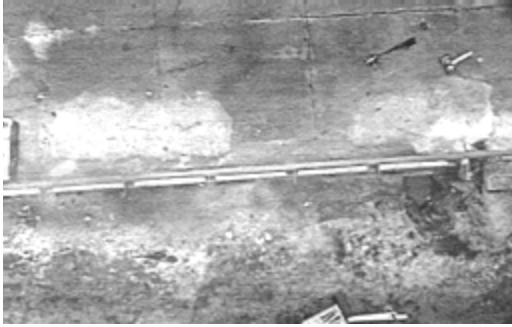

0.619 s

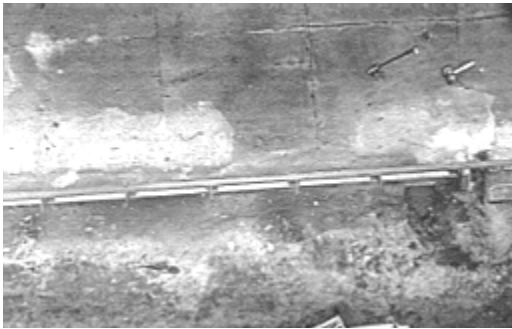

0.991 s



1.486 s

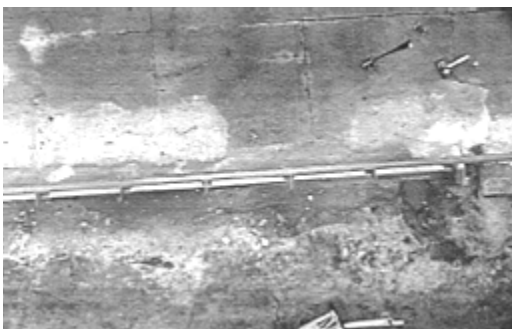

1.981 s



**Figure 24. Sequential Photographs for Test 448523-1
(Overhead and Frontal Views) (Continued).**

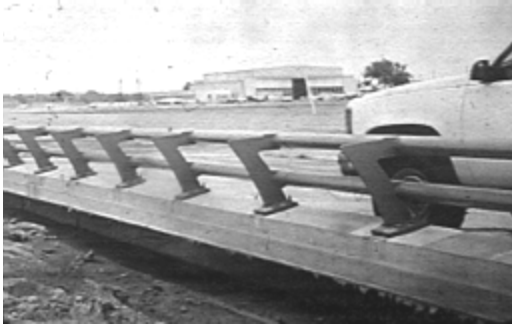

0.000 s

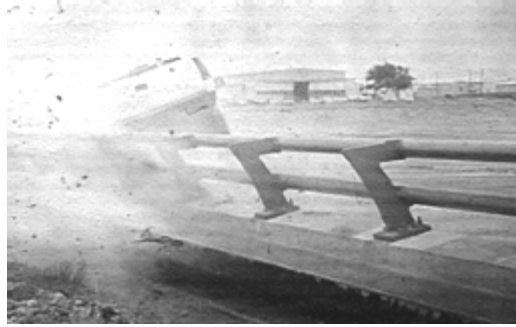

0.619 s

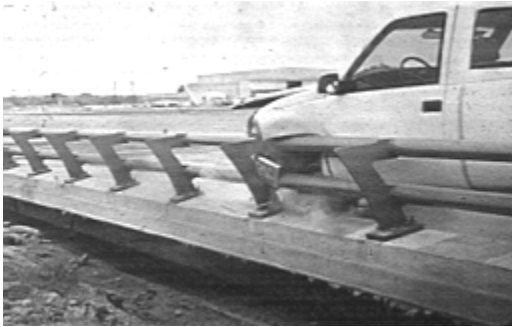

0.050 s

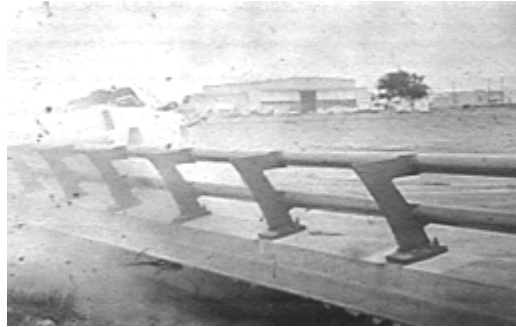

0.991 s



0.149 s



1.486 s



0.371 s

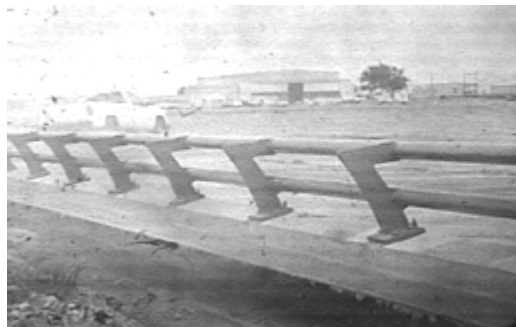

1.981 s

Figure 25. Sequential Photographs for Test 448523-1 (Rear View).



0.000 s



0.075 s

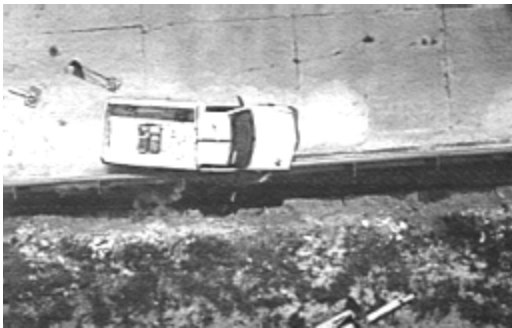

0.149 s



0.249 s



Figure 26. Sequential Photographs for Test 409260-1 (Overhead and Frontal Views).

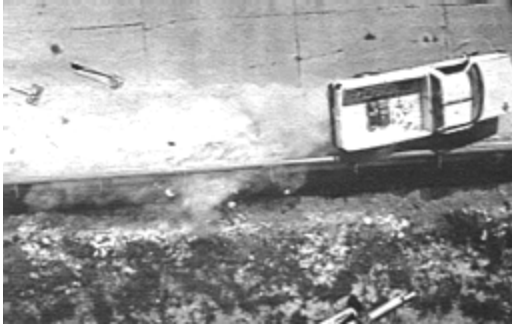

0.423 s

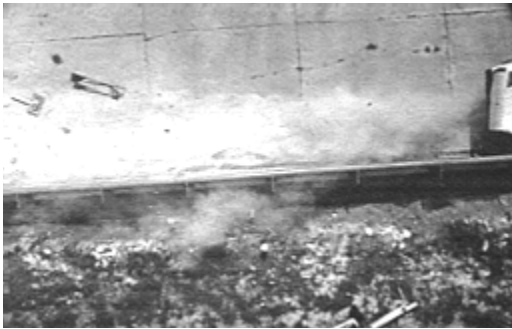

0.623 s

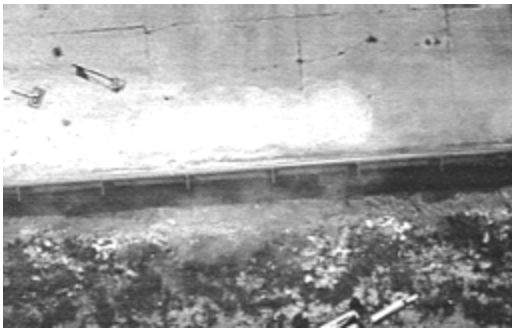

0.996 s

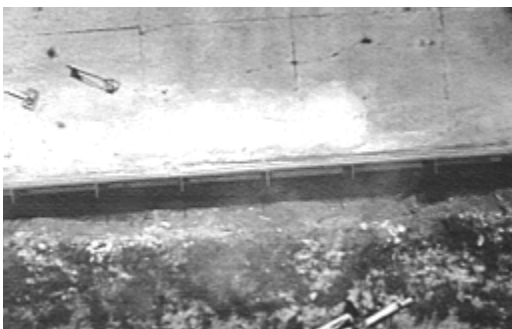

1.619 s



**Figure 26. Sequential Photographs for Test 409260-1
(Overhead and Frontal Views) (Continued).**



0.000 s



0.075 s



0.149 s



0.249 s

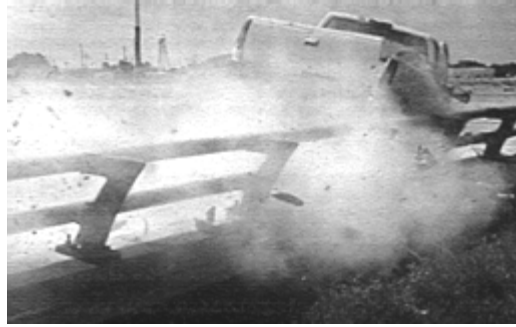

0.423 s

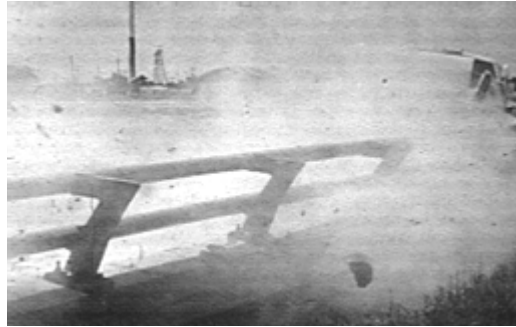

0.623 s



0.996 s



1.619 s

Figure 27. Sequential Photographs for Test 409260-1 (Rear View).

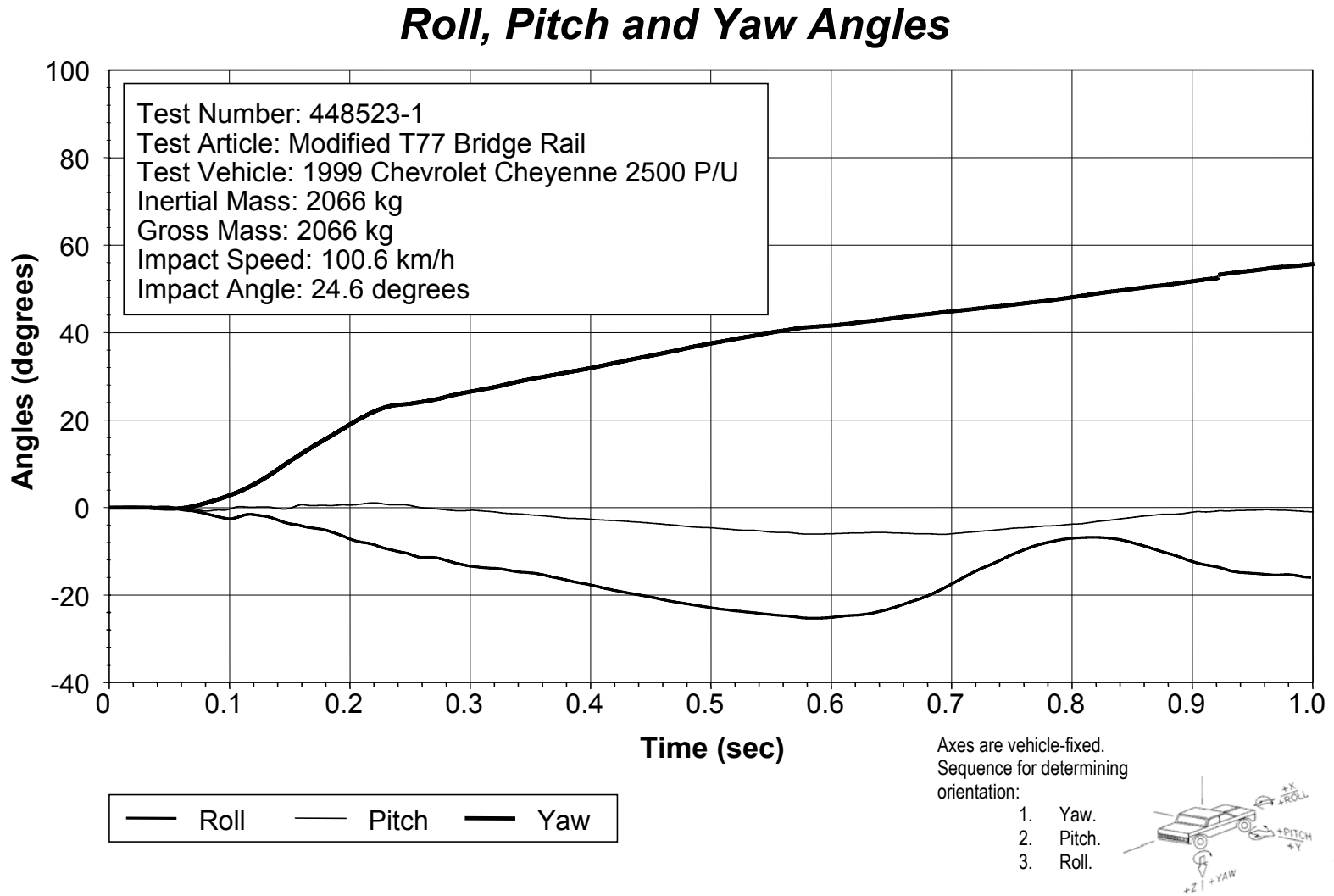
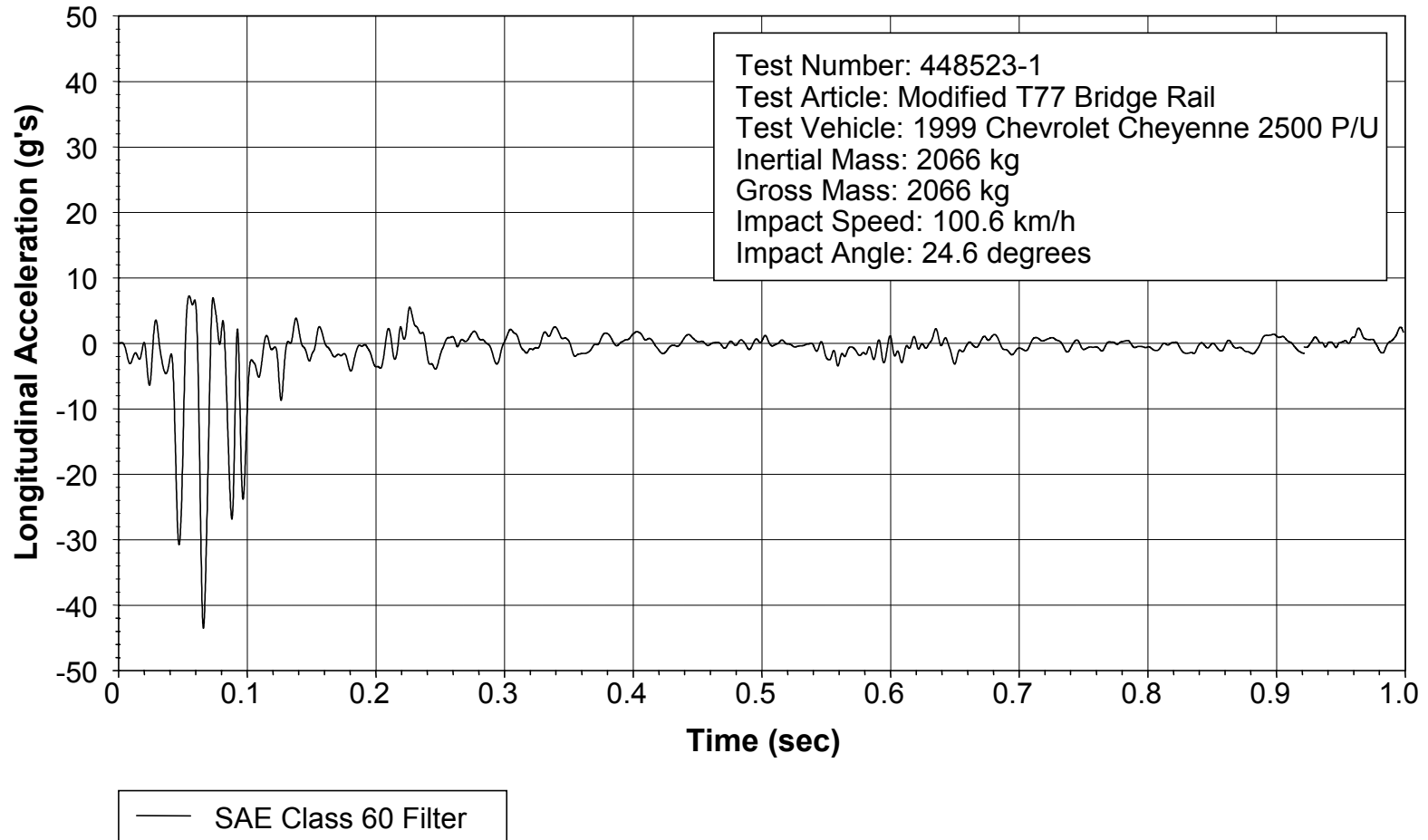

Figure 28. Vehicular Angular Displacements for Test 448523-1.

X Acceleration at CG



**Figure 29. Vehicle Longitudinal Accelerometer Trace for Test 448523-1
(Accelerometer Located at Center of Gravity).**

Y Acceleration at CG

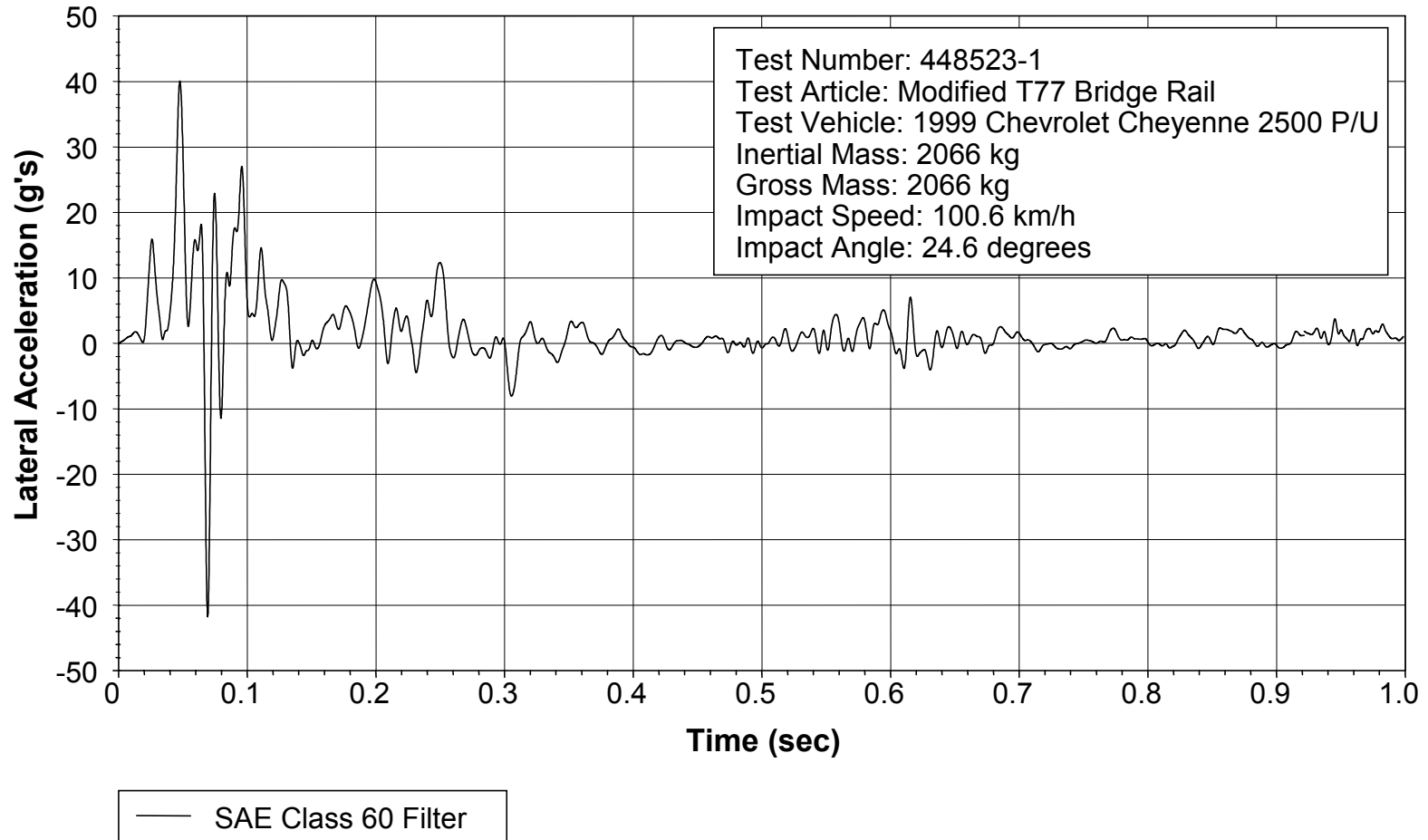

Figure 30. Vehicle Lateral Accelerometer Trace for Test 448523-1 (Accelerometer Located at Center of Gravity).

Z Acceleration at CG

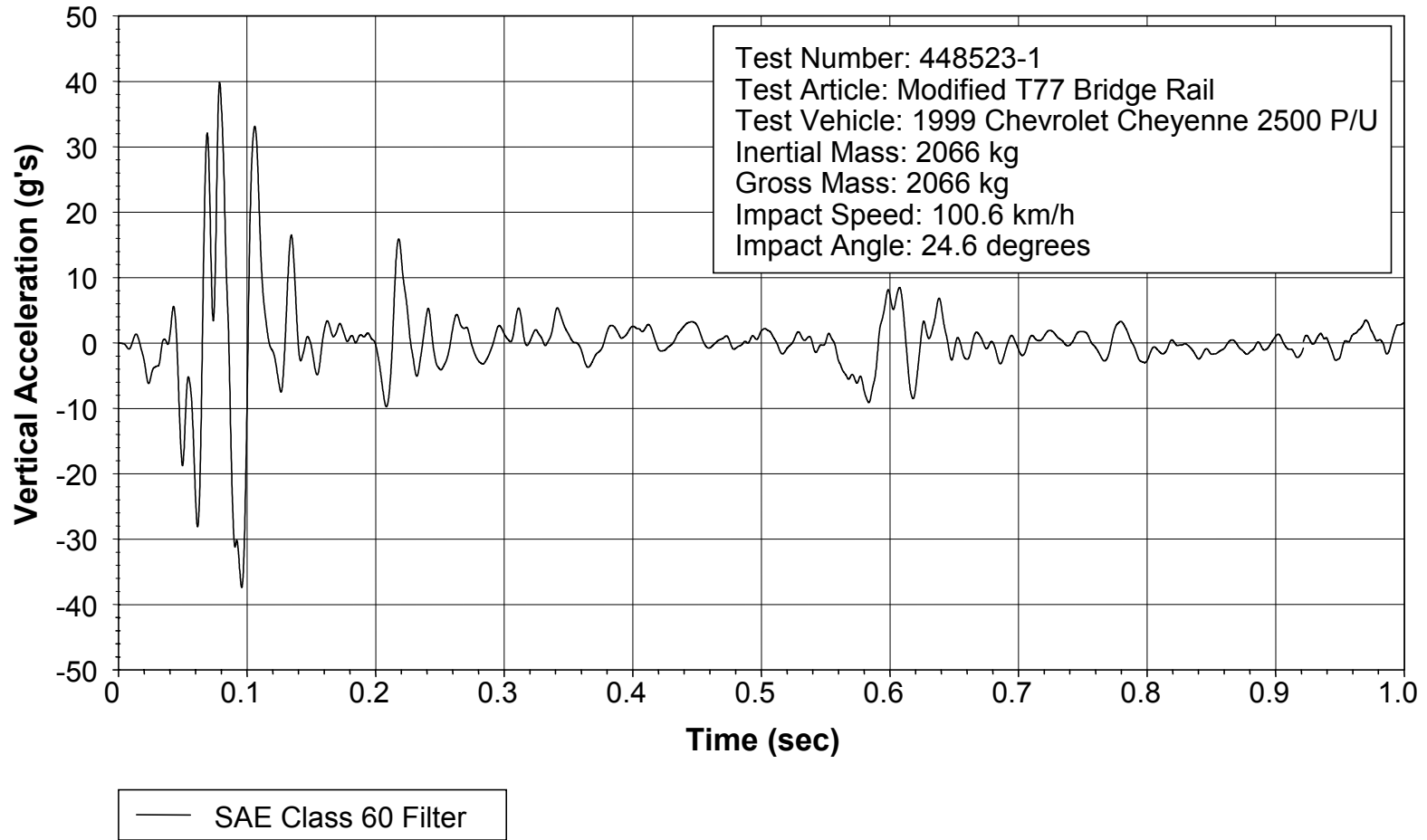
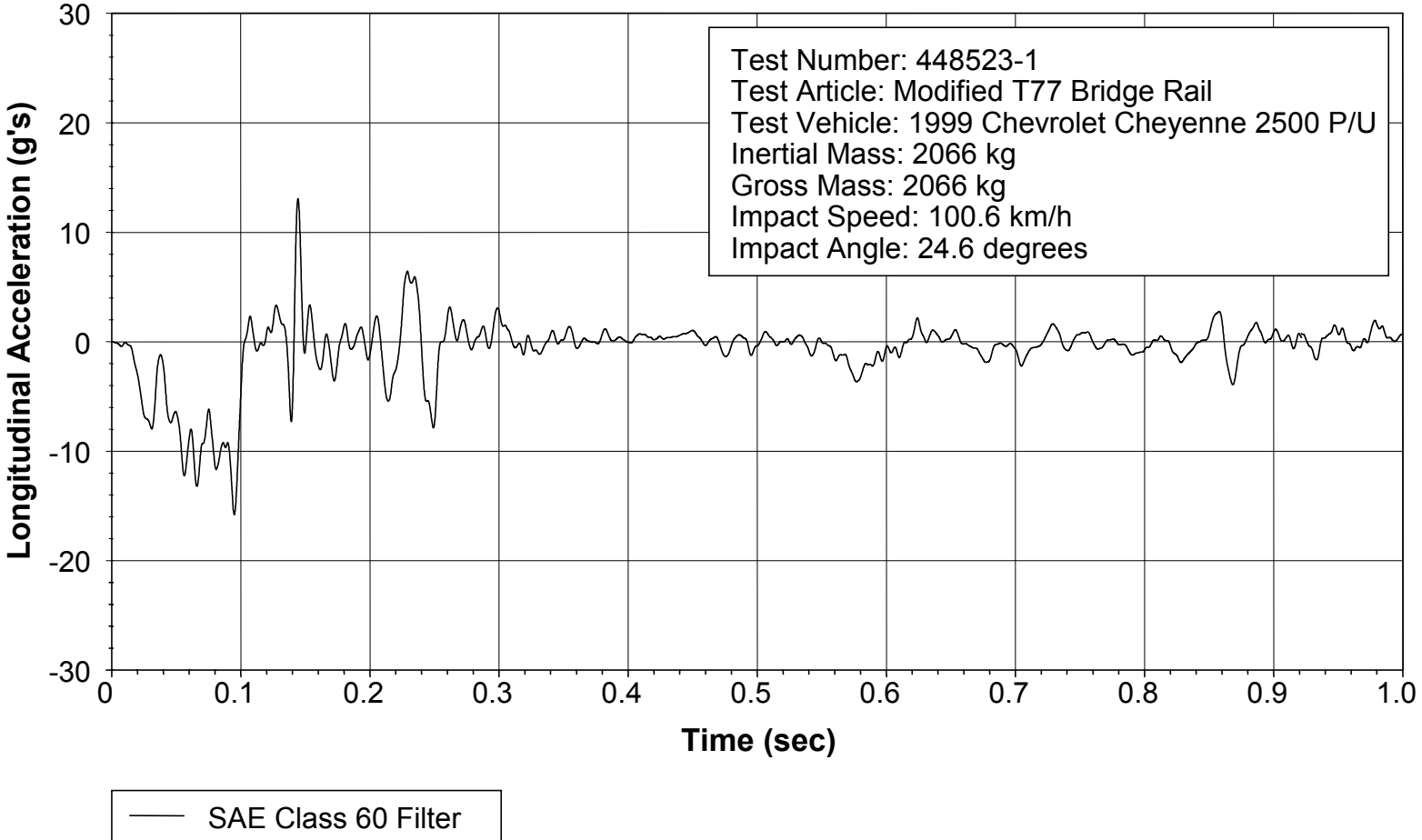

Figure 31. Vehicle Vertical Accelerometer Trace for Test 448523-1 (Accelerometer Located at Center of Gravity).

X Acceleration Over Rear Axle



67

Figure 32. Vehicle Longitudinal Accelerometer Trace for Test 448523-1 (Accelerometer Located Over Rear Axle).

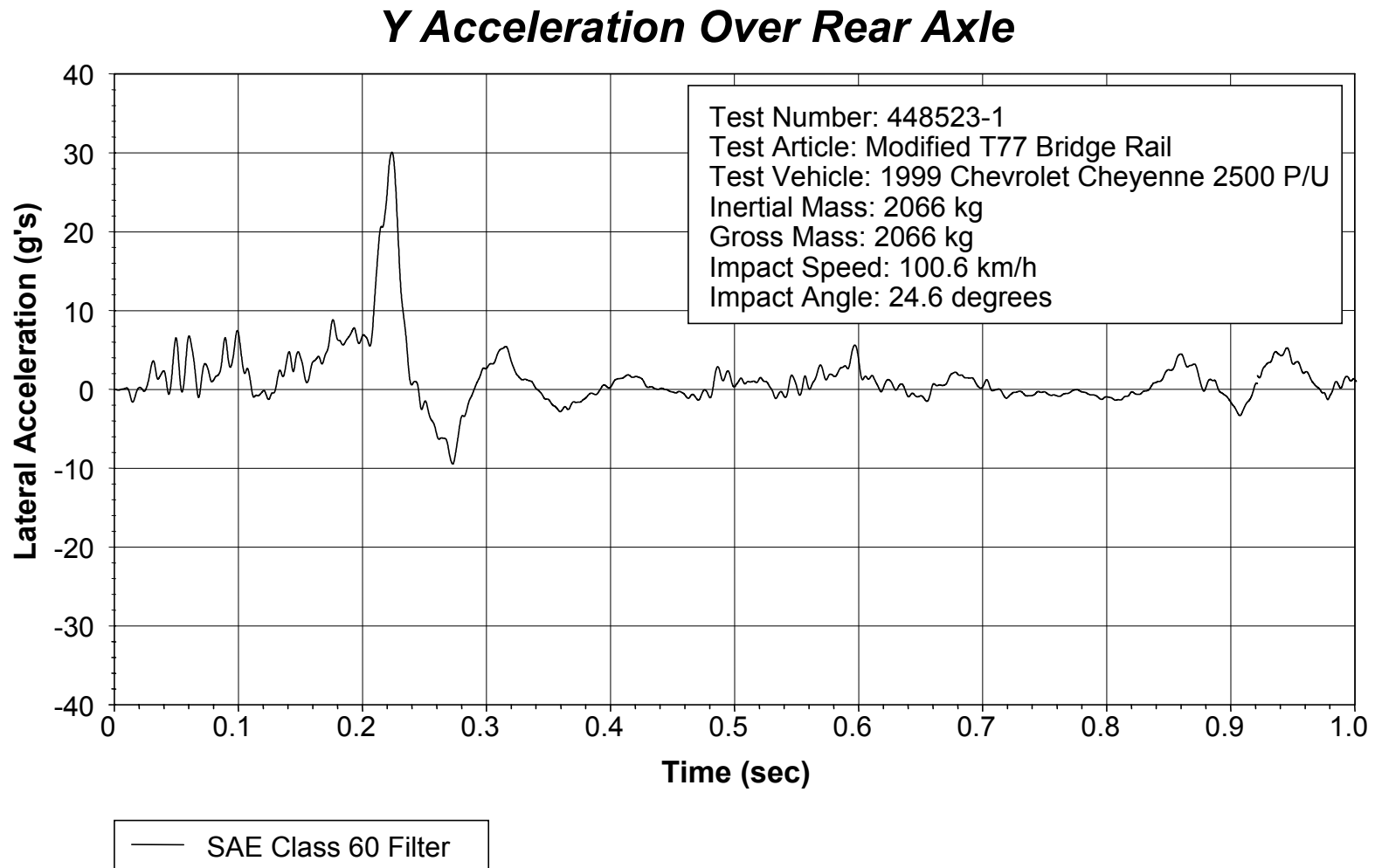

**Figure 33. Vehicle Lateral Accelerometer Trace for Test 448523-1
(Accelerometer Located Over Rear Axle).**

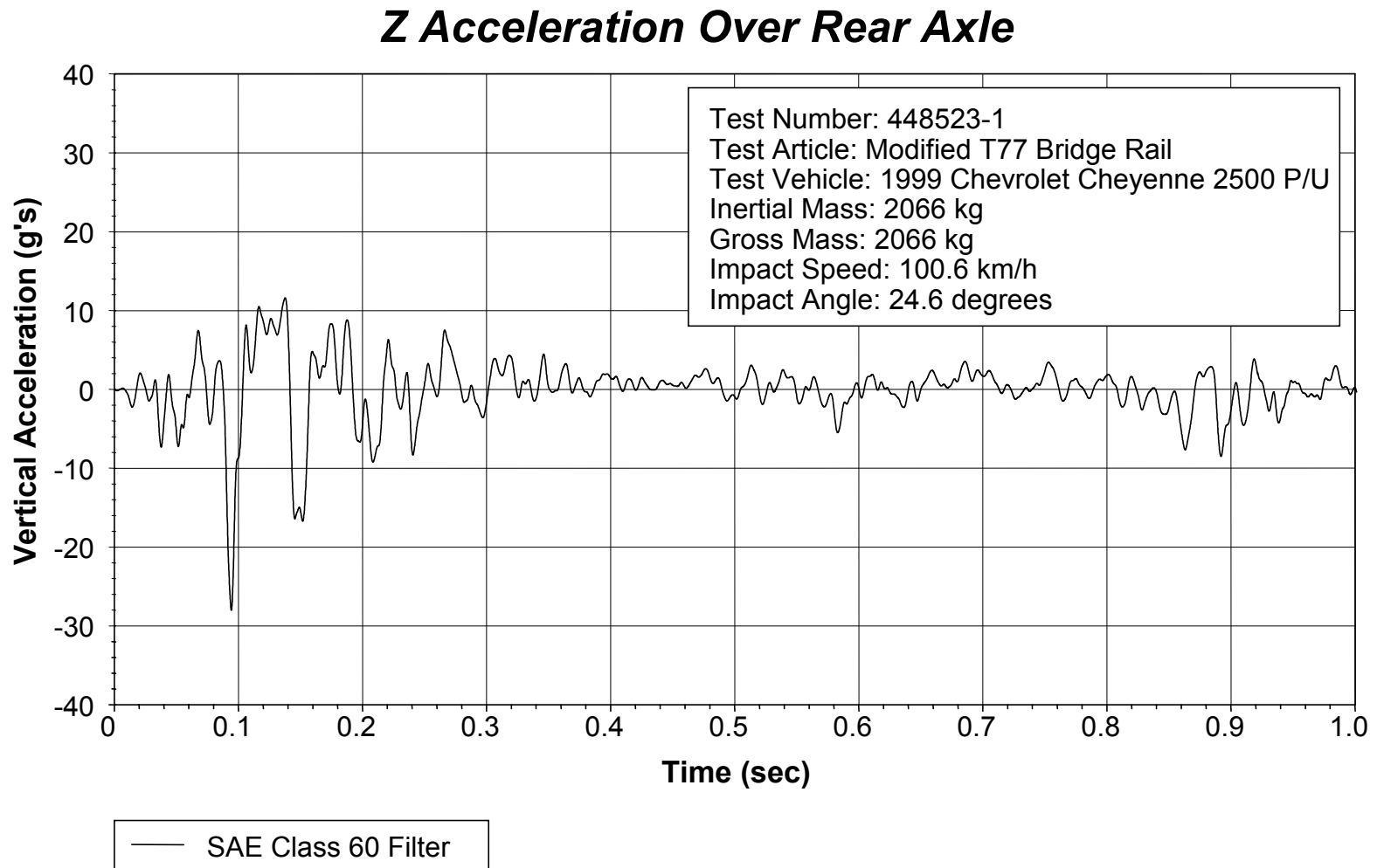

**Figure 34. Vehicle Vertical Accelerometer Trace for Test 448523-1
(Accelerometer Located Over Rear Axle).**

Roll, Pitch and Yaw Angles

Test Number: 409260-1
 Test Article: Modified T77 Bridge Rail
 Test Vehicle: 2000 Chevrolet Cheyenne 2500 P/U
 Inertial Mass: 2050 kg
 Gross Mass: 2050 kg
 Impact Speed: 99.9 km/h
 Impact Angle: 25.1 degrees

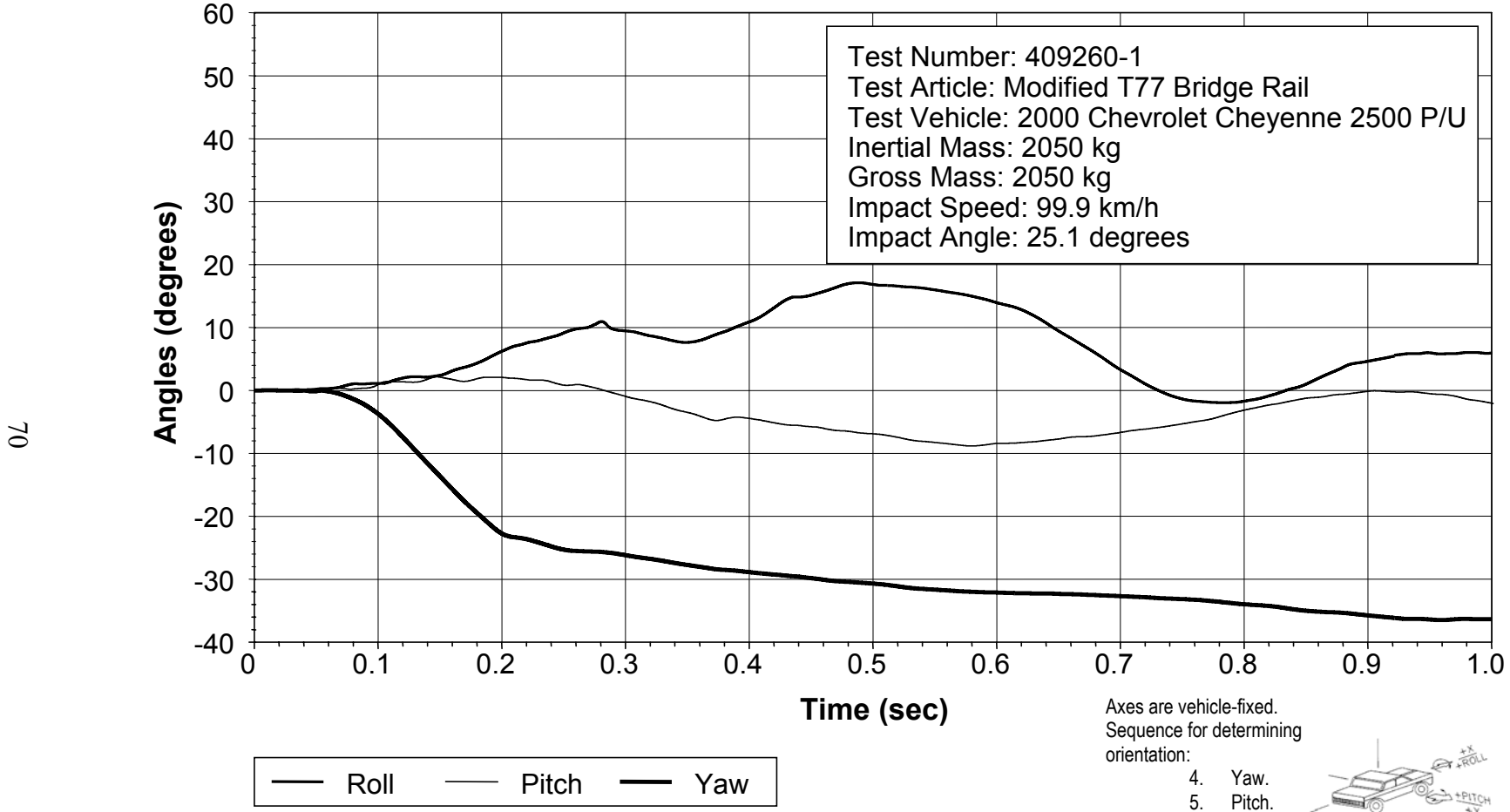

Axes are vehicle-fixed.
 Sequence for determining orientation:

4. Yaw.
5. Pitch.
6. Roll.

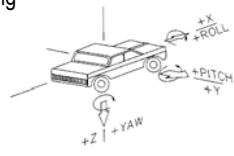
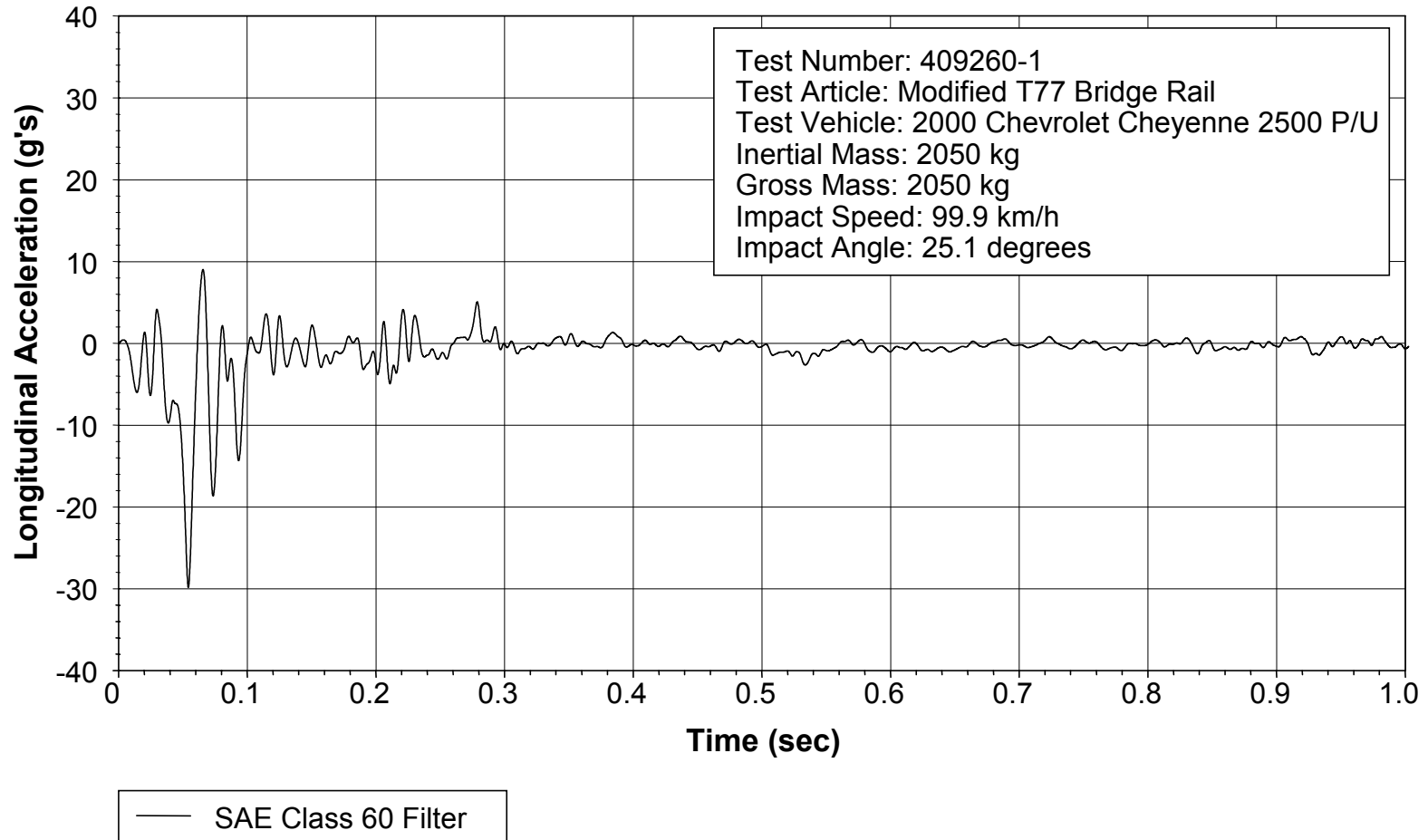

Figure 35. Vehicular Angular Displacements for Test 409260-1.

X Acceleration at CG



**Figure 36. Vehicle Longitudinal Accelerometer Trace for Test 409260-1
(Accelerometer Located at Center of Gravity).**

Y Acceleration at CG

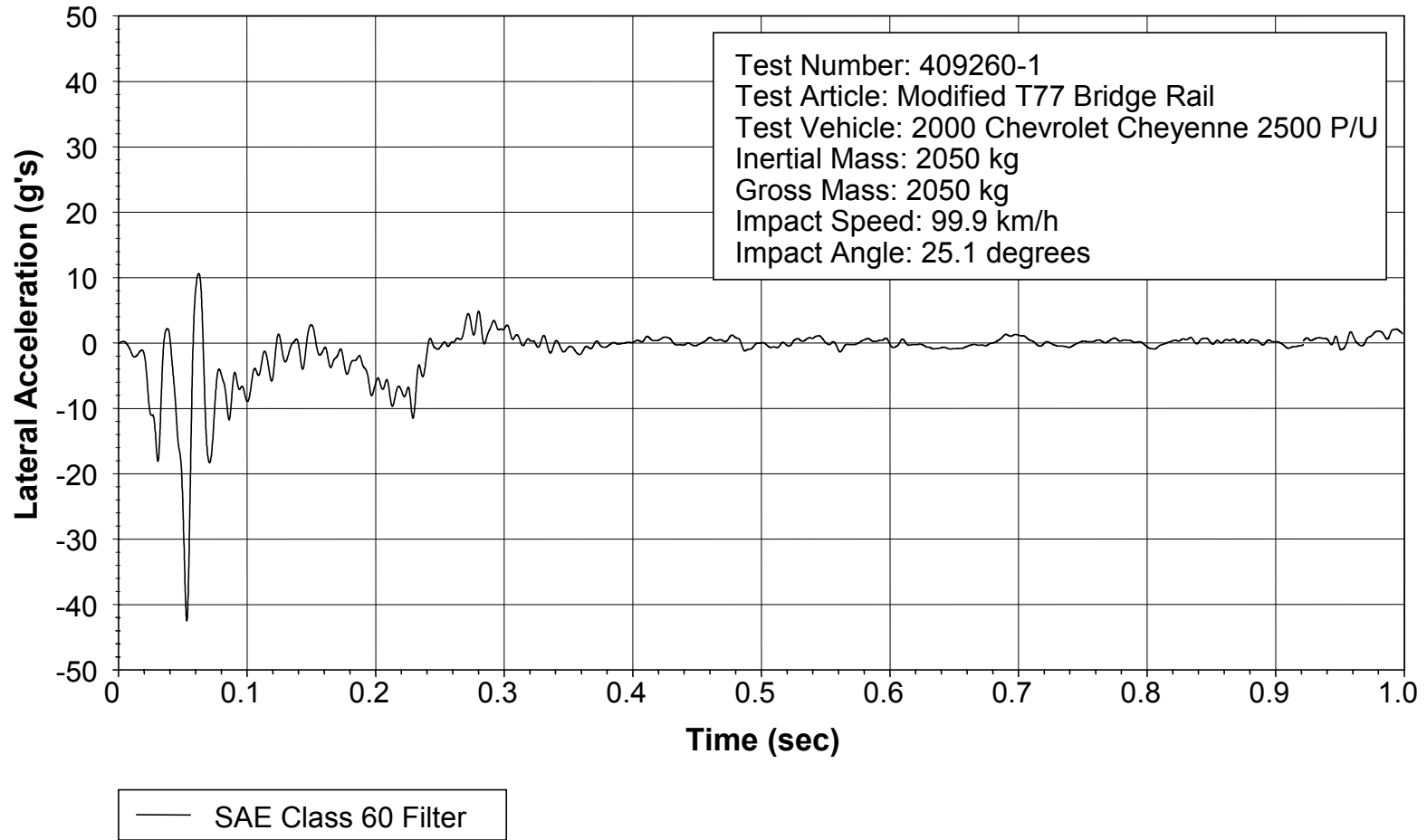

Figure 37. Vehicle Lateral Accelerometer Trace for Test 409260-1 (Accelerometer Located at Center of Gravity).

Z Acceleration at CG

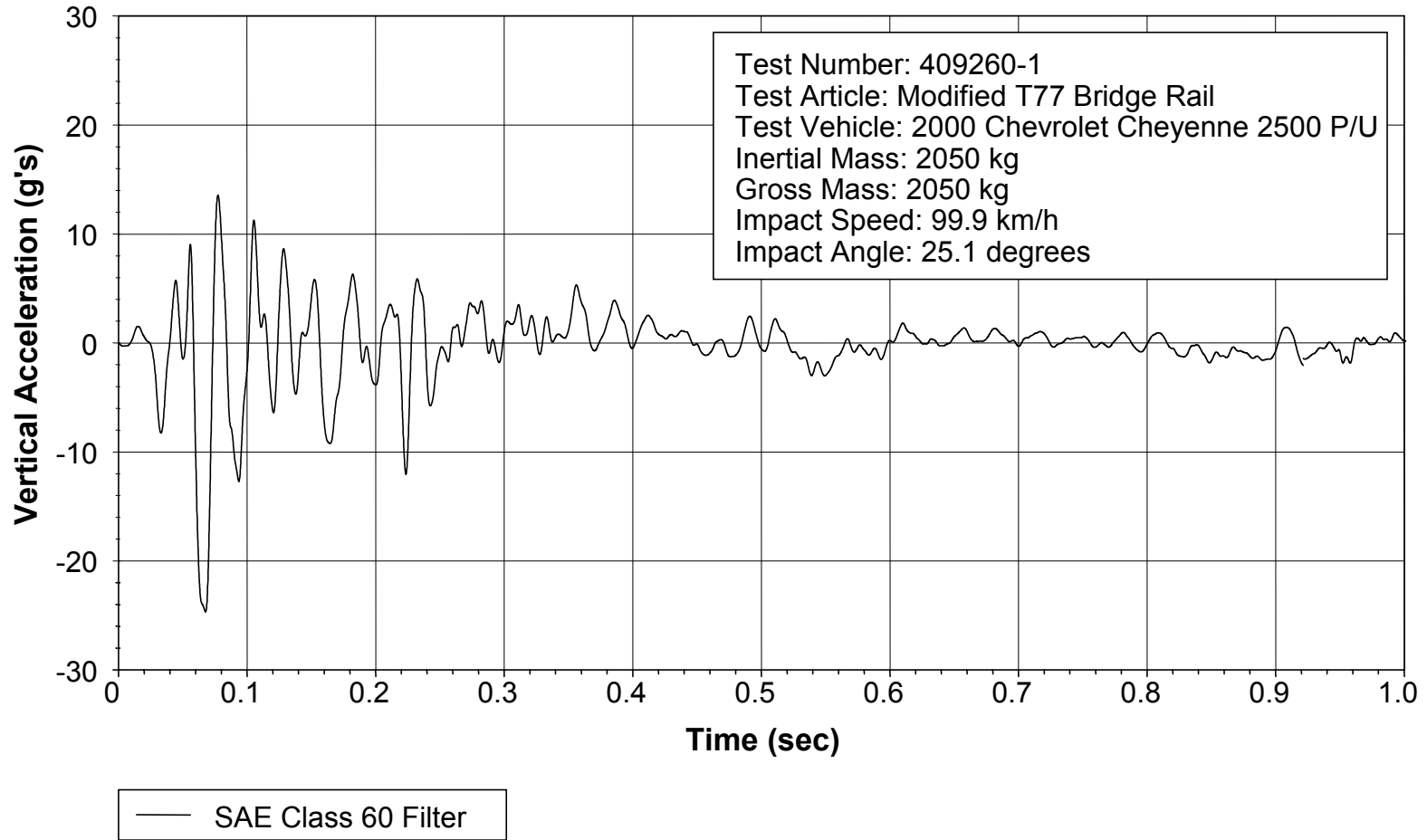
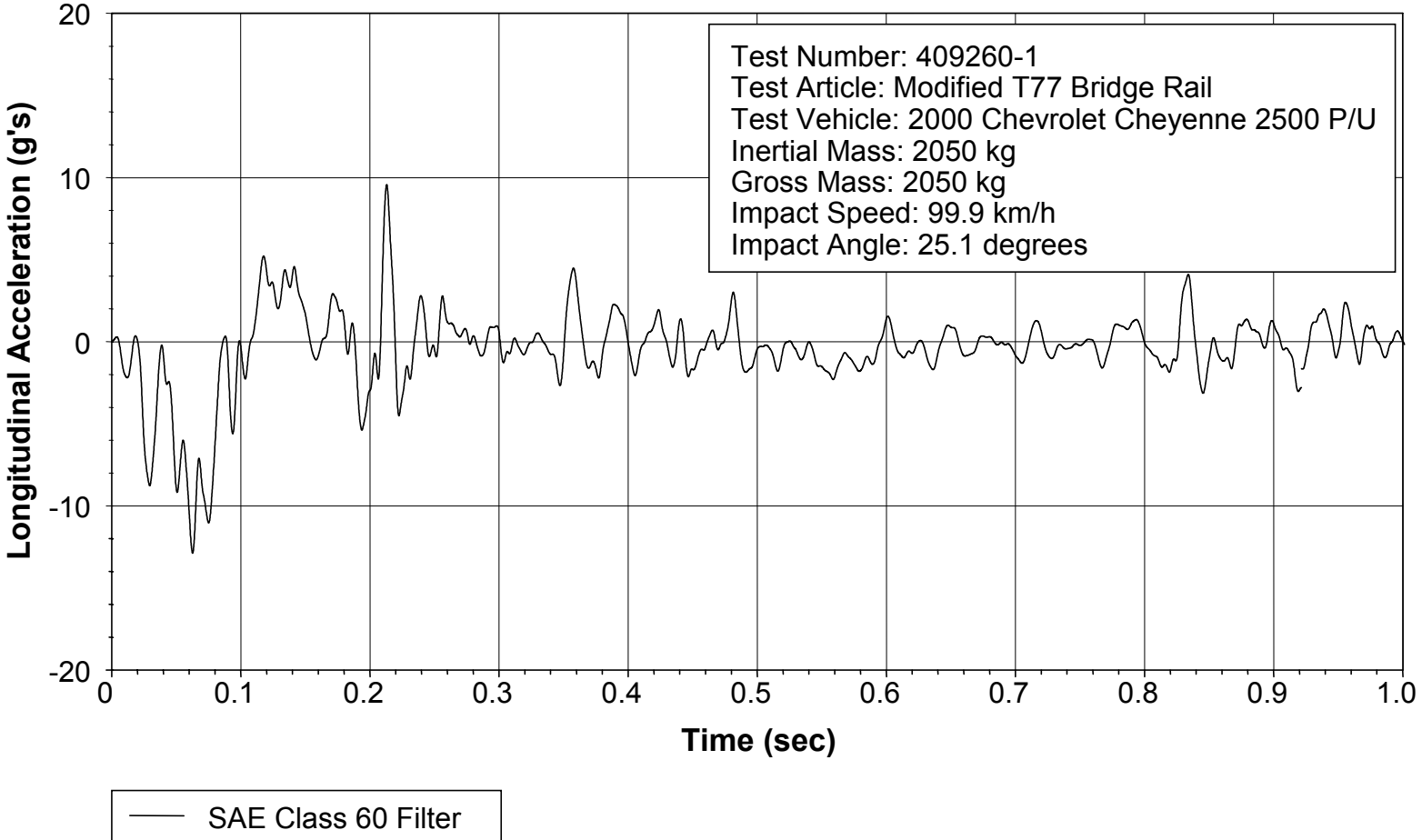

Figure 38. Vehicle Vertical Accelerometer Trace for Test 409260-1
(Accelerometer Located at Center of Gravity).

X Acceleration Over Rear Axle



74

Figure 39. Vehicle Longitudinal Accelerometer Trace for Test 409260-1 (Accelerometer Located Over Rear Axle).

Y Acceleration Over Rear Axle

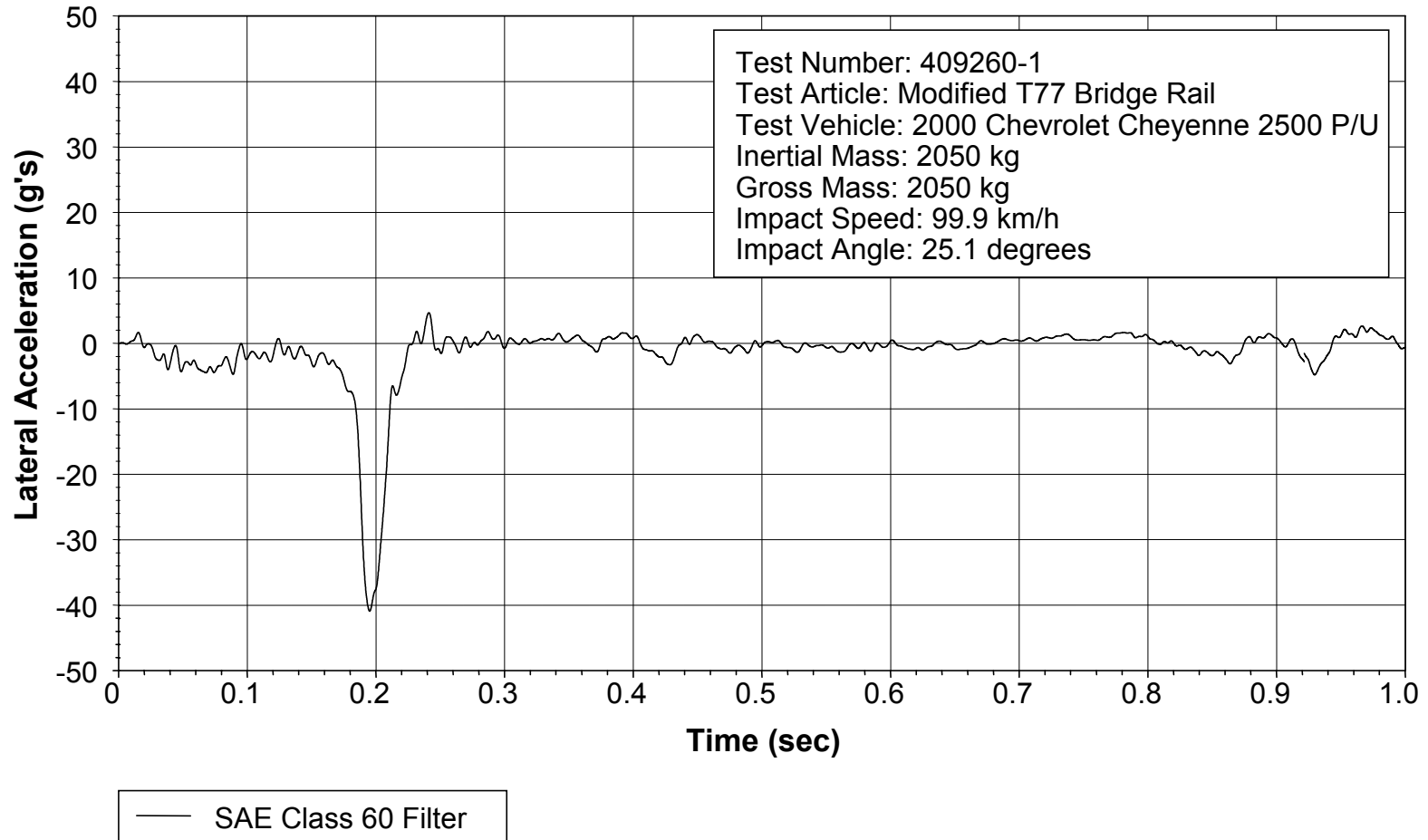

**Figure 40. Vehicle Lateral Accelerometer Trace for Test 409260-1
(Accelerometer Located Over Rear Axle).**

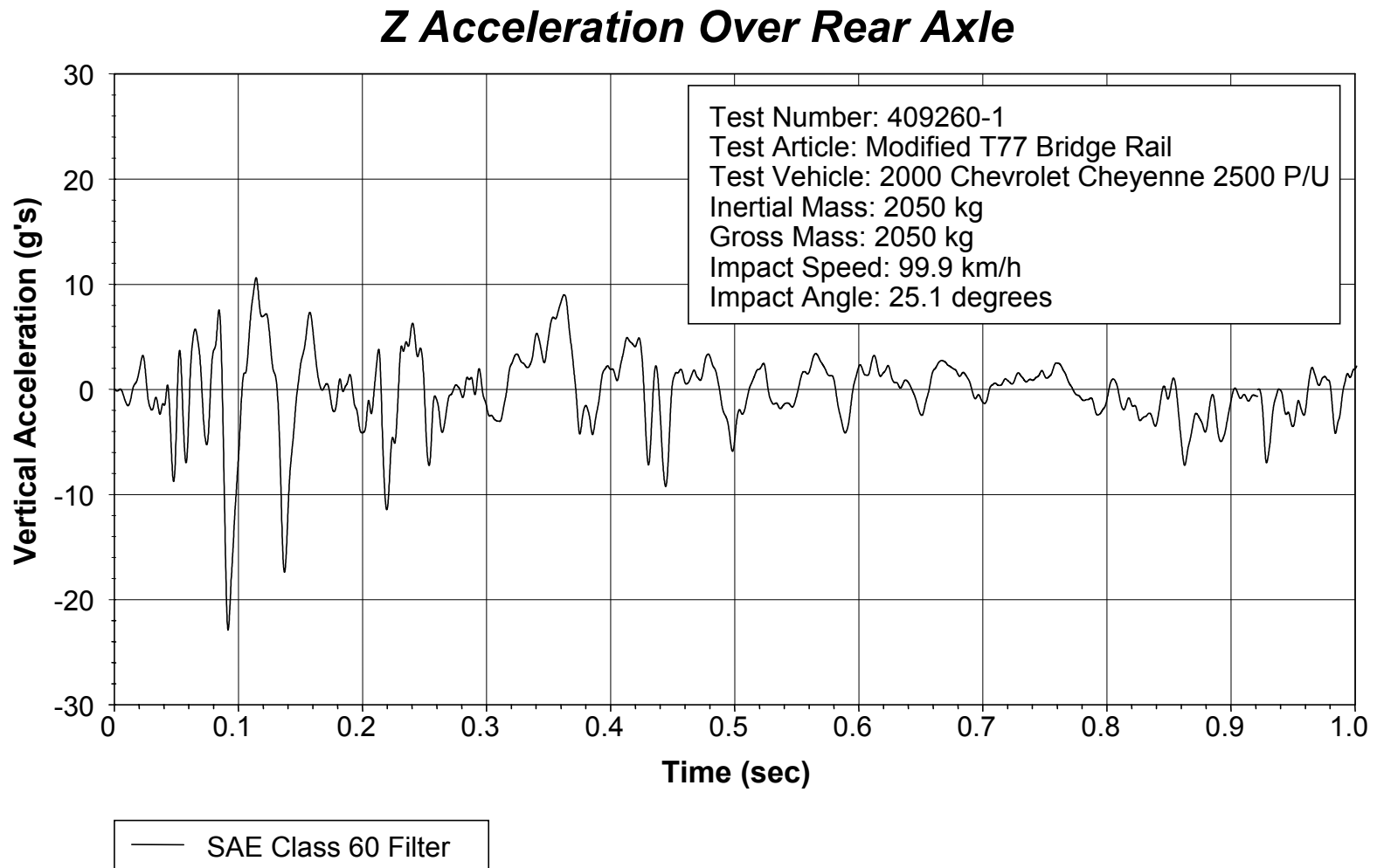

**Figure 41. Vehicle Vertical Accelerometer Trace for Test 409260-1
(Accelerometer Located Over Rear Axle).**