

ELEVATION

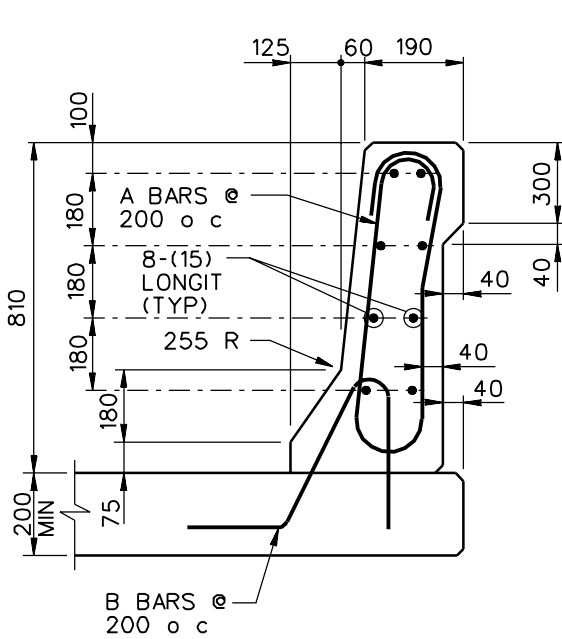

SBC04b

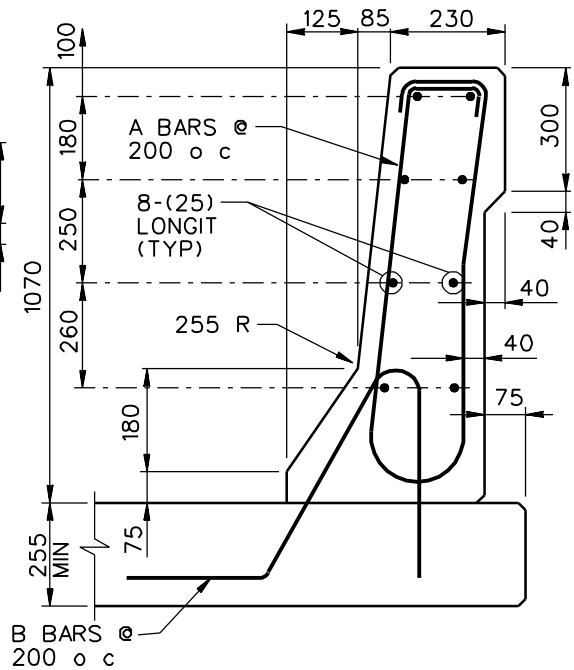

SBC04c

1994

F SHAPE CONCRETE BRIDGE RAILINGS

SBC04b-c

SHEET NO.

REF. NO.

1 of 4

| SYSTEM | A | B | C | D | E | F | G | H | I |
|--------|-----|----|----|----|-----|-----|----|-----|-----|
| SBC04b | 620 | 60 | 25 | 0 | 380 | 275 | 50 | 340 | 262 |
| SBC04c | 850 | 65 | 90 | 25 | 620 | 285 | 75 | 370 | 320 |

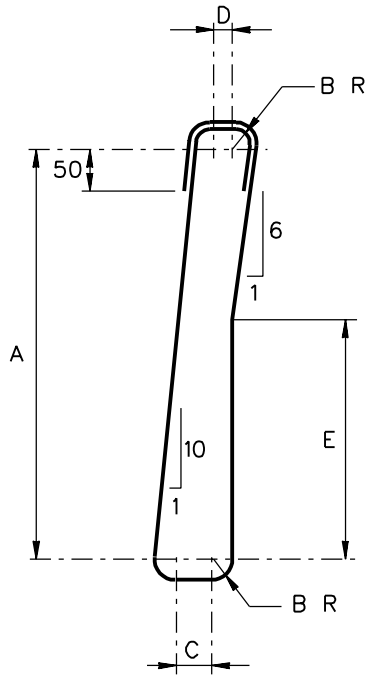

BAR A (15)

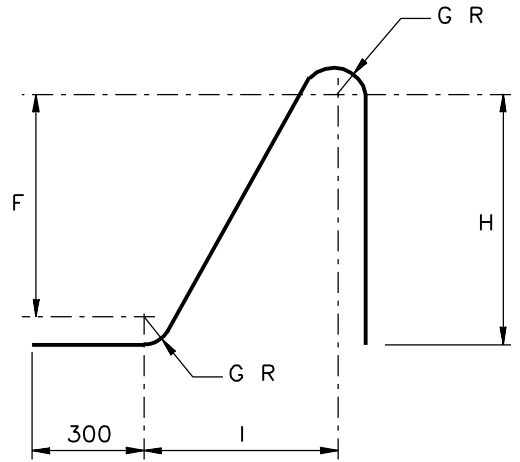

BAR B (15)

1994

F-SHAPE CONCRETE BRIDGE RAILINGS

SBC04b-c

| | |
|-----------|----------|
| SHEET NO. | REF. NO. |
|-----------|----------|

3 of 4