

STANDARD LENGTH IS 116 1/2" [2960 mm]
DESIGN SPEED IS 44 mph [70 km/h]

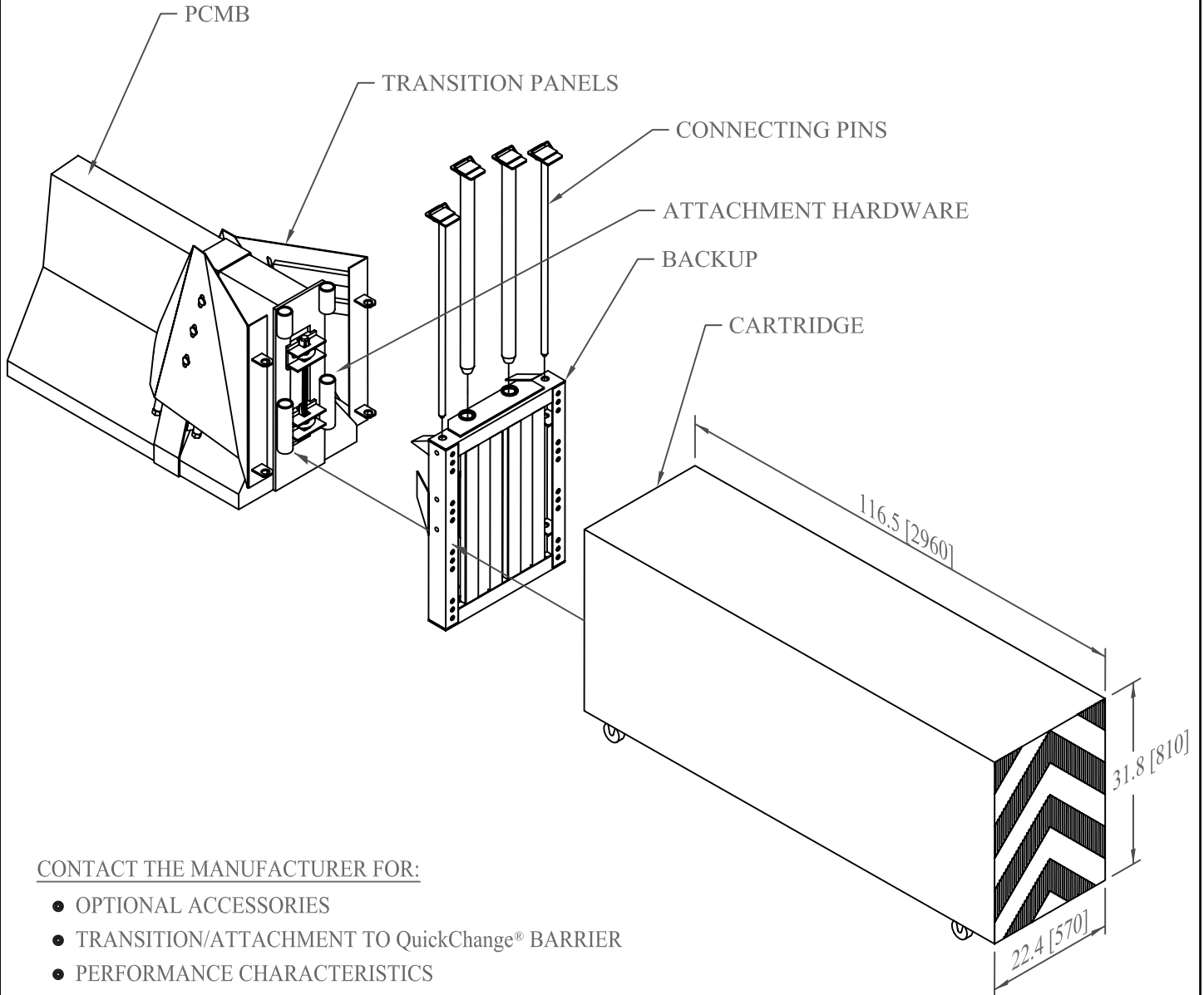

CONTACT THE MANUFACTURER FOR:

- OPTIONAL ACCESSORIES
- TRANSITION/ATTACHMENT TO QuickChange® BARRIER
- PERFORMANCE CHARACTERISTICS

N-E-A-T® SYSTEM

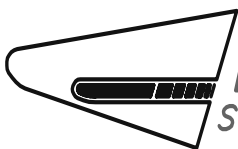

**ENERGY ABSORPTION
SYSTEMS, INC.**

SHEET NO.

DATE:

1 of 2

4/19/05

INTENDED USE

The N-E-A-T System is an end treatment solution for temporary barrier ends in work zones, secondary roads and many municipal applications. This **N**on-redirective **E**nergy **A**bsorbing **T**erminal provides impact protection for speeds up to 43.5 mph [70 km/h]. It meets NCHRP 350 Test Level 2 criteria for non-redirective crash cushions.

The N-E-A-T System cartridge is lightweight, weighing less than 298 lb [135 kg]. It is compact as well, measuring less than 10 ft [3.0 m] in length. The system can be installed in less than 15 minutes without the use of special tools or heavy equipment. It can be attached to the ends of Jersey-shaped portable concrete barrier and the moveable Quickchange® Barrier. See sheets SWC01 and SWC04 for barrier details.

The N-E-A-T System consists of a unique configuration of aluminum cells encased in an aluminum shell that withstands harsh weather and environmental conditions. The basic components of the system are:

- 1) A one piece aluminum cartridge
- 2) Steel backup and attachment hardware
- 3) Steel transition panels

The system's unique design allows for easy attachment to the end of concrete barrier utilizing the barrier's existing pin and loop connection. The nose of the system is equipped with a chevron sign which is reversible for unidirectional or bidirectional traffic. The cartridge features integrated caster wheels to aid in repositioning and resetting.

- Length = 9' 8 1/2" [2.96 m]
- Width = 22 1/2" [570 mm]
- Height = 32" [810 mm]
- Weight = 297 lb [135 kg]

APPROVALS:

http://safety.fhwa.dot.gov/roadway_dept/road_hardware/barriers/pdf/cc-25.pdf

Contact Information

Corporate Offices:
35 East Wacker Dr., 11th Floor
Chicago, IL 60601-2076
Telephone: (312) 467-6750
FAX: (312) 467-1356
<http://www.energyabsorption.com/>

N-E-A-T® SYSTEM

SCI10

SHEET NO.

DATE

2 of 2

4/19/05

