

TL-4 4 Cable MASH Test and Post Spacing Chart

MASH TEST	Line Post Spacing*
3-10	7'-0"
3-11	7'-0"
3-11	21'-0"
4-12**	21'-0"

*±6" post spacing tolerance
 **All tests are impacted near the midpoint of the installation at a 25° angle, except the 4-12 test, which is impacted at 15°.

Cable Tension Chart*

-10 °F	8600
0 °F	8200
10 °F	7800
20 °F	7400
30 °F	7000
40 °F	6600
50 °F	6200
60 °F	5800
70 °F	5400
80 °F	5000
90 °F	4600
100 °F	4200
110 °F	3800

*Allowable Deviation from Chart +/- 10%

Cable Release & Anchor Post

Terminal Post (Welded Rebar Socket)

Terminal Post (Welded Rebar Socket)

Line Post (Welded Rebar Socket)

MASH 4 Cable Tests PROPRIETARY TO GIBRALTAR



TL-4 4 Cable System Layout

Gibraltar Cable Barrier Systems

Scale: **NTS** Date: **12-19-18**

Layout: **ANSI B** Drafter: **JP**

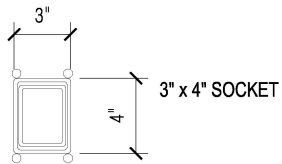
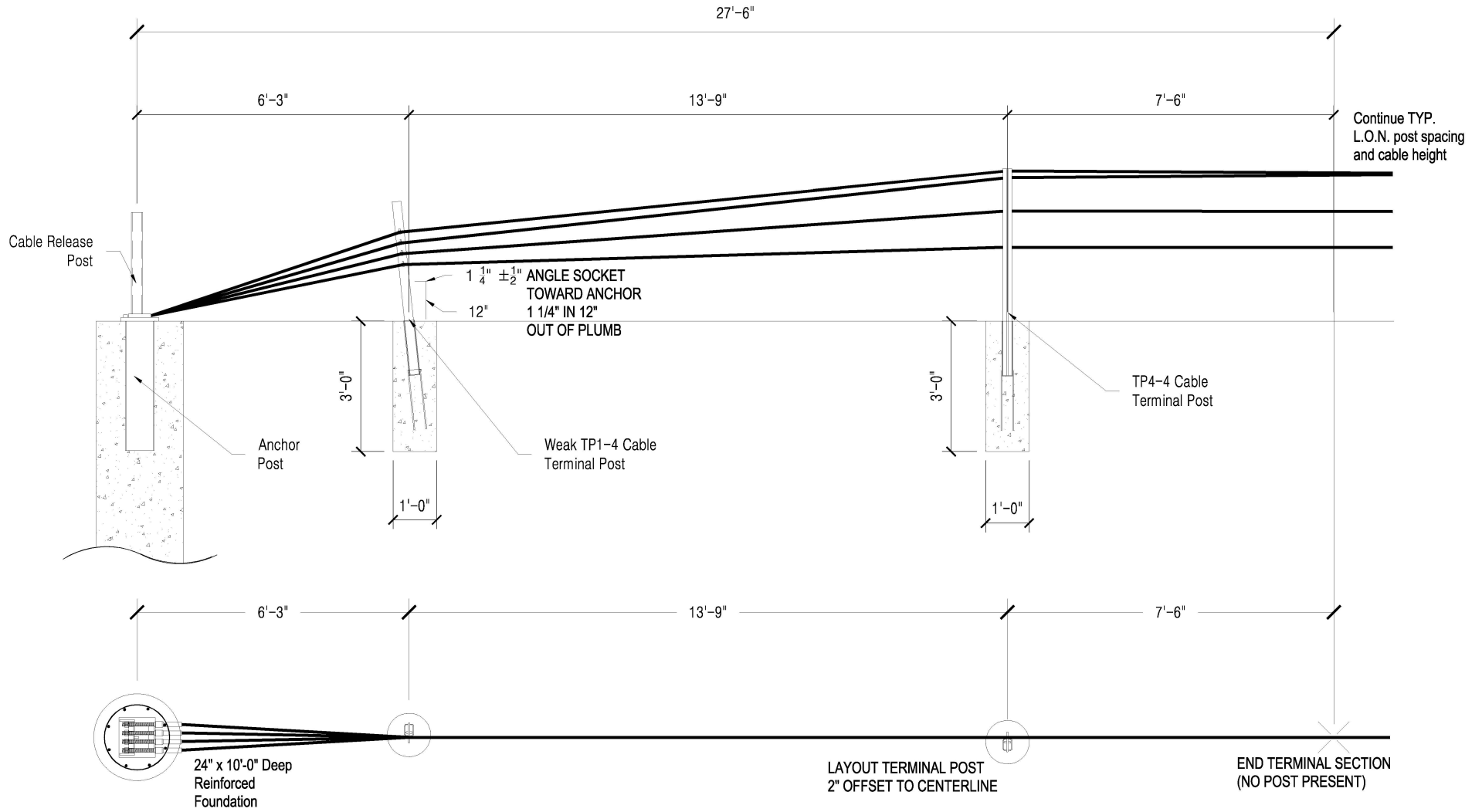

PROPRIETARY TO GIBRALTAR



TL-3 4-Cable MASH Terminal Layout	
Gibraltar Cable Barrier Systems	
Scale: NTS	Date: 1-23-19
Layout: ANSI B	Drafter: BH

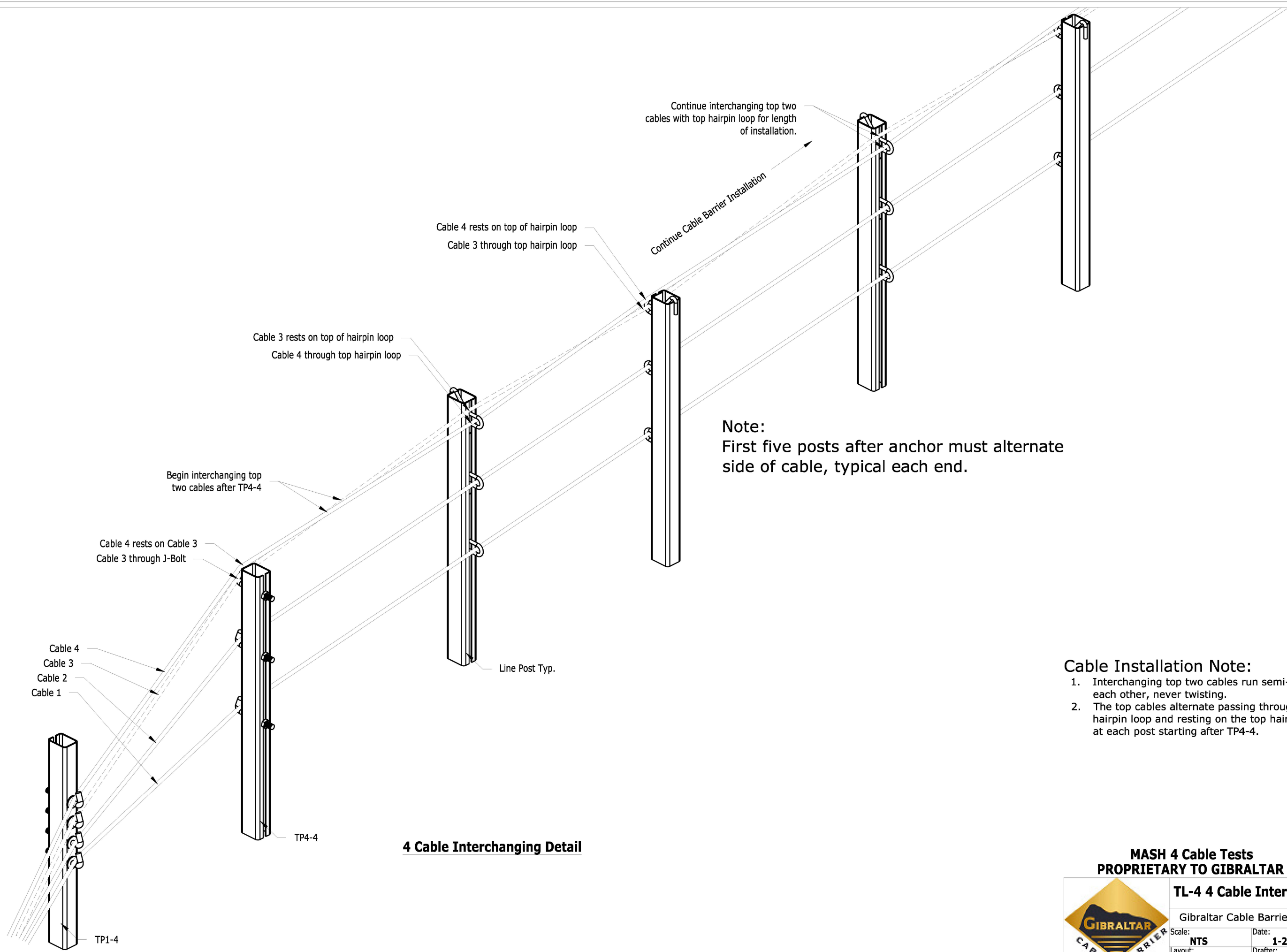

Note:
 First five posts after anchor must alternate side of cable, typical each end.

- Cable Installation Note:**
1. Interchanging top two cables run semi-parallel to each other, never twisting.
 2. The top cables alternate passing through the top hairpin loop and resting on the top hairpin loop at each post starting after TP4-4.

4 Cable Interchanging Detail

**MASH 4 Cable Tests
 PROPRIETARY TO GIBRALTAR**

	TL-4 4 Cable Interchanging	
	Gibraltar Cable Barrier Systems	
	Scale: NTS	Date: 1-2-19
	Layout: ANSI B	Drafter: JP

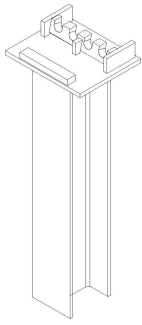

Anchor Post



Cable Release Post

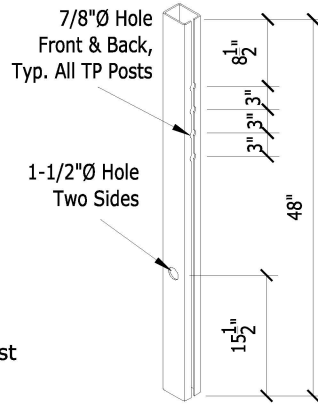

TP1-4
Terminal Post
No. 1/Weak

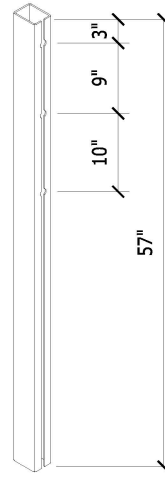

TP4-4
Terminal Post

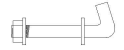

J-BLT
J-Bolt

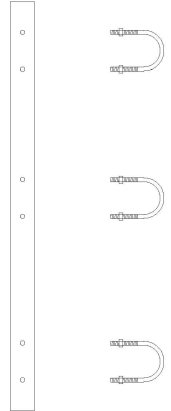

U-Bolt Lock-Plate Assembly



RH STUD ATF ASSY
Anchor Terminal Fitting RH Stud



ATF
Anchor Terminal Fitting



ATF-END
Anchor Terminal Fitting End

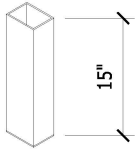

Tube Socket
(Steel or Plastic)

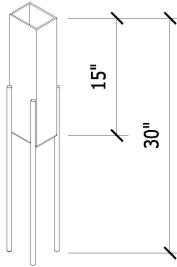

SOCK-S
Short Rebar Socket

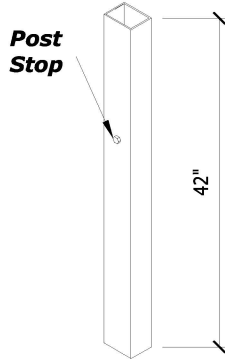

TUBE-D
Driven Socket

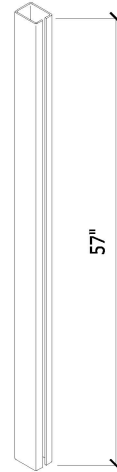

4-LNP-S
Line Post/Socketed

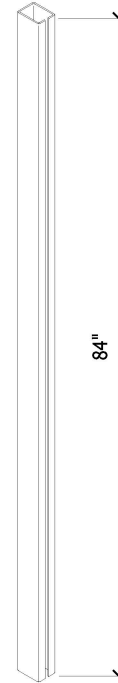

4-LNP-D
Line Post/Driven



4-HPIN ALUM



4-LOCK
TL4 Lockplate



RH/LH SWAGE ASSY



CSTB
Cable Splice Turnbuckle



WEDGE
W-1 Wedge



ACORN
Acorn w/ Wedge



TORP
Longitudinal Section ONLY
Torpedo Cable Splice

PROPRIETARY TO GIBRALTAR



TL4 MASH System Parts

Gibraltar Cable Barrier Systems

Scale:	NTS	Date:	12/19/18
Layout:	ANSI B	Drafter:	BH

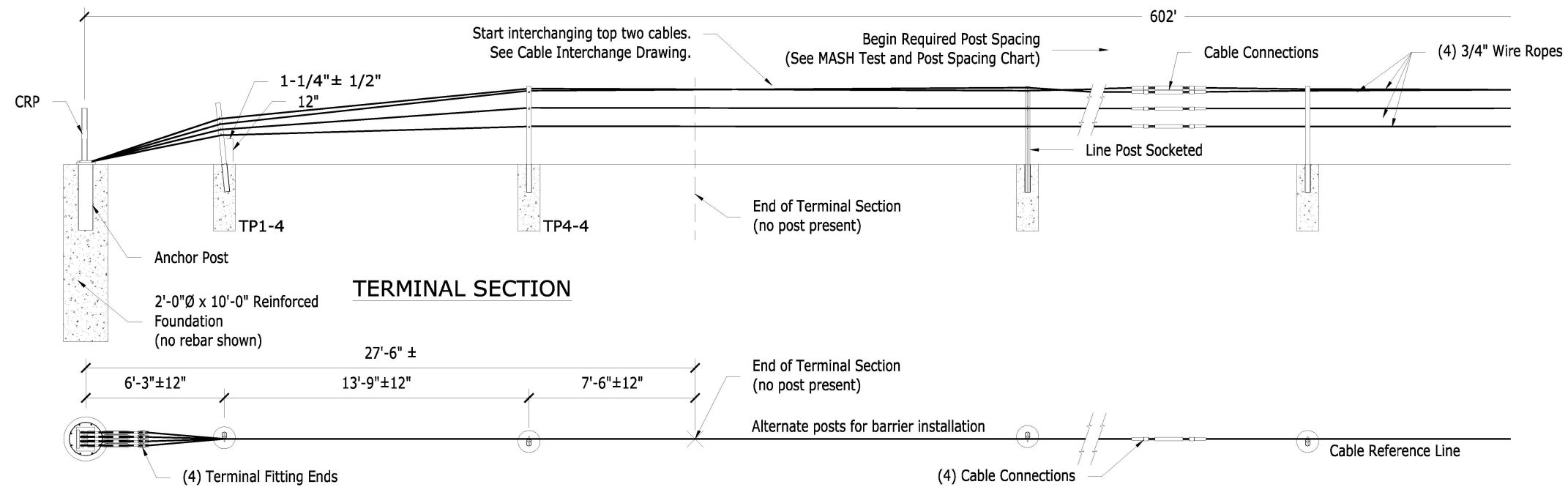

TERMINAL SECTION

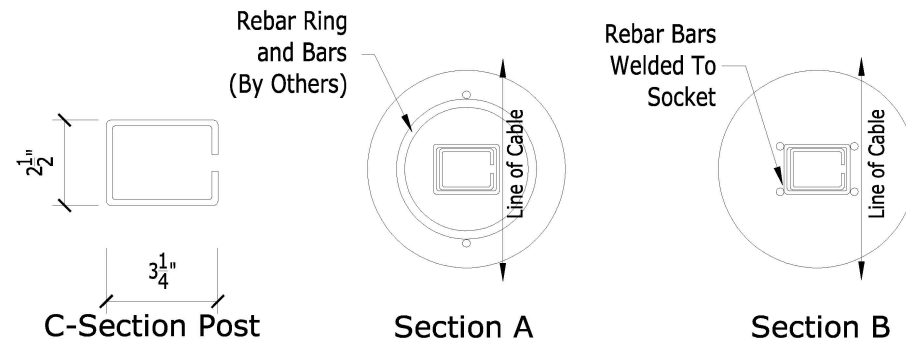
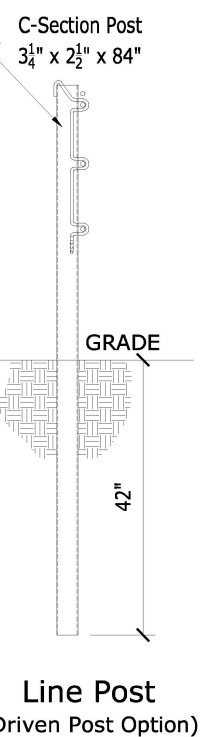
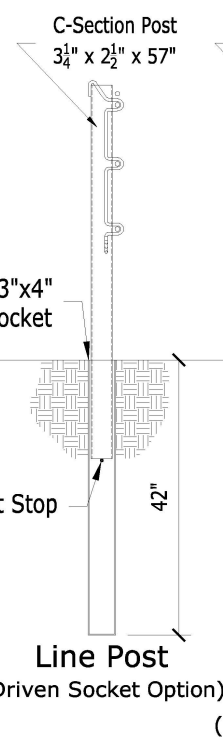
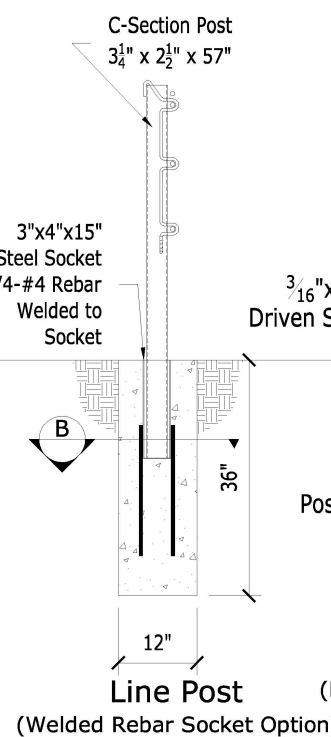
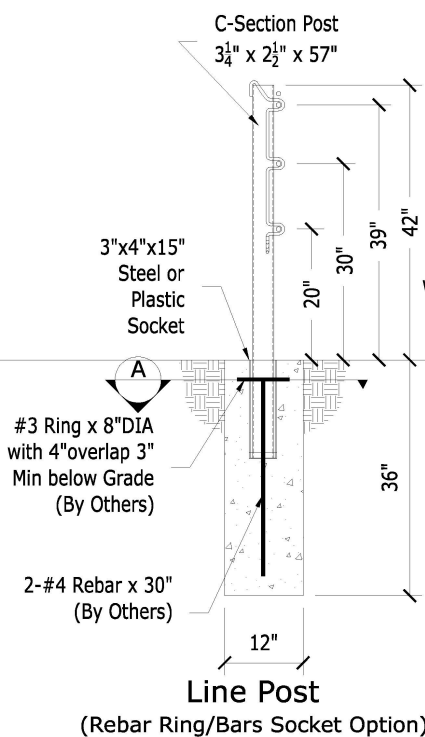
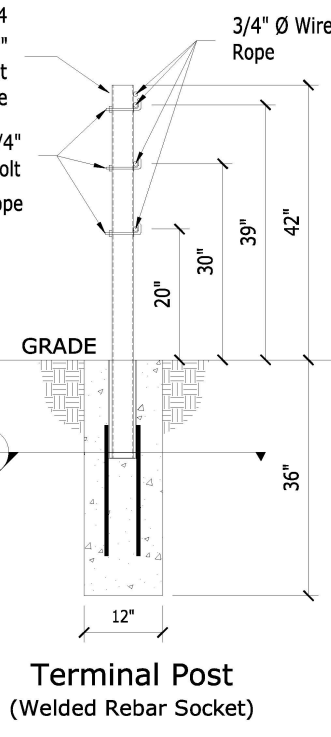
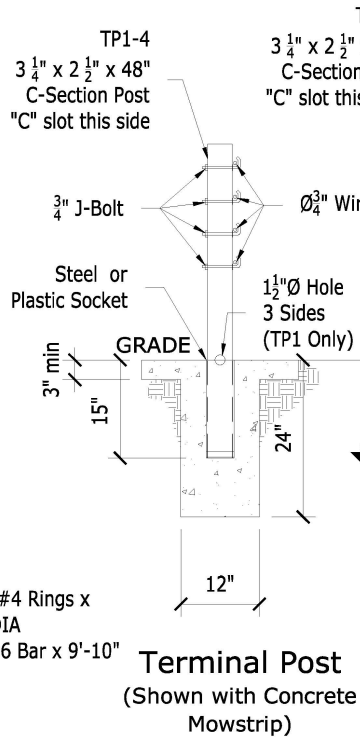
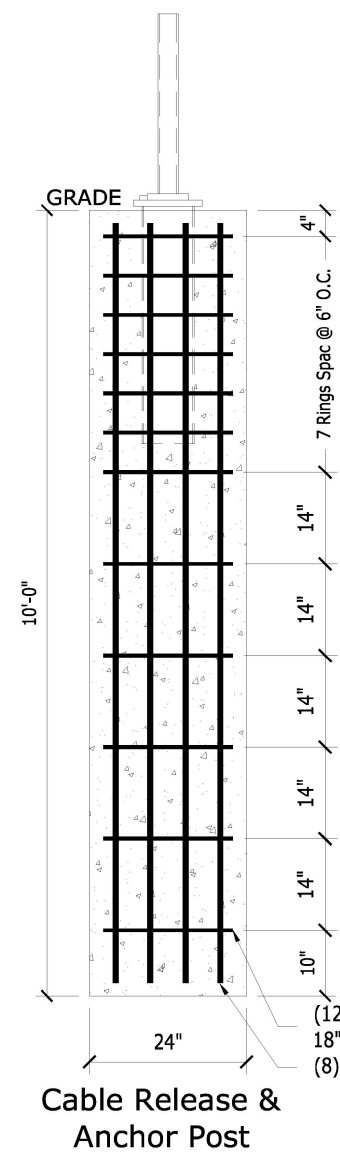

Cable Tension Chart*

-10 °F	8600
0 °F	8200
10 °F	7800
20 °F	7400
30 °F	7000
40 °F	6600
50 °F	6200
60 °F	5800
70 °F	5400
80 °F	5000
90 °F	4600
100 °F	4200
110 °F	3800

TL-4 4 Cable MASH Test and Post Spacing Chart

MASH TEST	Line Post Spacing
3-10	7'-0"
3-11	7'-0"
3-11	21'-0"
4-12	21'-0"

*±6" post spacing tolerance *Allowable Deviation from Chart +/- 10%

MASH 4 Cable Tests PROPRIETARY TO GIBRALTAR



TL-4 4M Cable System Layout

Gibraltar Cable Barrier Systems

Scale: **NTS** Date: **1-7-2019**

Layout: **ANSI B** Drafter: **BH**

- GENERAL NOTES:**
- For additional information contact Gibraltar, Inc. at 1-833-715-0810 or see the manufacturer's product manual.
 - All concrete shall be per specification; minimum 2500 PSI.
 - The Cable Barrier System shall be installed on shoulders or on medians with slopes of 6:1 or flatter. If installed on slopes steeper than 6:1 up to 4:1 the TL-4 system performs as a TL-3 and Gibraltar must be contacted for various guidelines related to placement. (Max. Post Spacing 18' on 4:1)
 - The Cable Barrier System is accepted by the FHWA Test Level - 4.
 - See the specification for delineation.
 - Rock Clause: Where solid rock is encountered:
 - For socketed post, continue digging 12" diameter, 15" deep into rock or the required plan depth, whichever comes first.
 - For driven post, core drill a 4" diameter hole 18" deep into rock or the required plan depth, whichever comes first.
 - For Anchor post, continue digging 24" diameter, 30" deep into rock or the required plan depth, whichever comes first.
 - The Gibraltar cable barrier system shall be installed in standard compacted soil. Soil must be well drained.
 - All non-welded rebar by others.
 - Minimum recommended line post foundation.
 - Without mowstrip, 36" Deep x 12" diameter foundations with #3 rebar ring x 8" diameter with two #4 rebar vertical bars 30" long or 30" welded rebar socket.
 - With 4" minimum depth hot mix asphalt, 30" deep x 12" diameter foundations with #3 rebar ring x 8" diameter with two #4 rebar vertical bars 30" long or 30" welded rebar socket.
 - With 3" minimum depth concrete mowstrip, 24" deep x 12" diameter foundations. (No rebar required).
 - Direct drive driven post and driven socket 42" deep.