

8 7 6 5 4 3 2 1

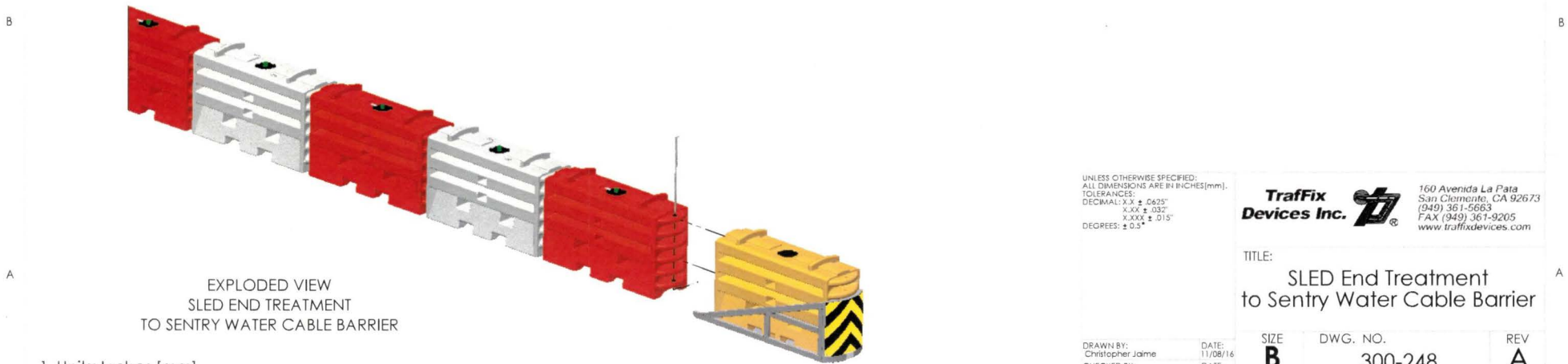
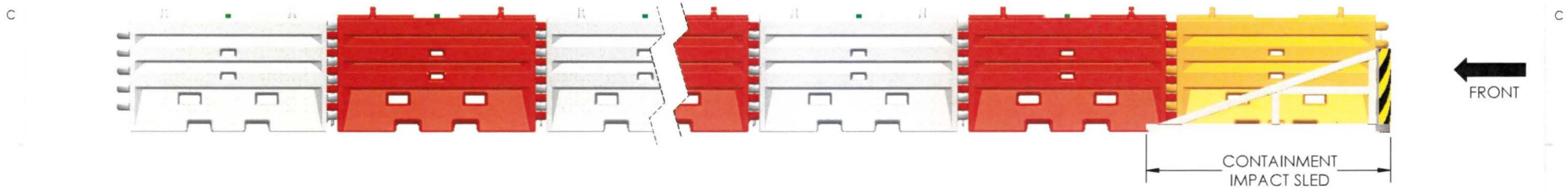
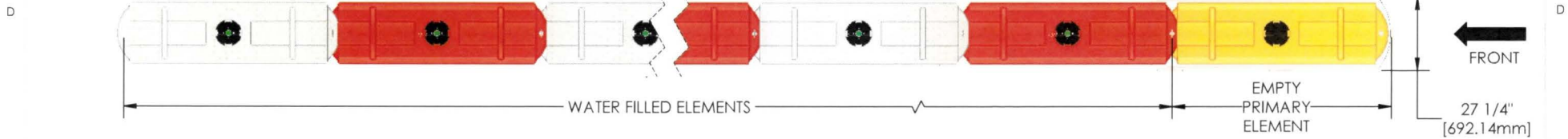

EXPLODED VIEW
SLED END TREATMENT
TO SENTRY WATER CABLE BARRIER

1. Units: Inches [mm]
NOTES: UNLESS OTHERWISE SPECIFIED

UNLESS OTHERWISE SPECIFIED:
ALL DIMENSIONS ARE IN INCHES(mm).
TOLERANCES:
DECIMAL: X.X ± .0625"
X.XXX ± .03"
X.XXXX ± .015"
DEGREES: ± 0.5°



160 Avenida La Pata
San Clemente, CA 92673
(949) 361-5663
FAX (949) 361-9205
www.traffixdevices.com

TITLE:
**SLED End Treatment
to Sentry Water Cable Barrier**

DRAWN BY:
Christopher Jaime
CHECKED BY:
FA
APPROVED BY:
FA

DATE:
11/08/16
DATE:
11/08/16
DATE:
11/08/16

SIZE
B

DWG. NO.
300-248

REV
A

SHEET 1 OF 1

8 7 6 5 4 3 2 1

8 7 6 5 4 3 2 1

D
C
B
A

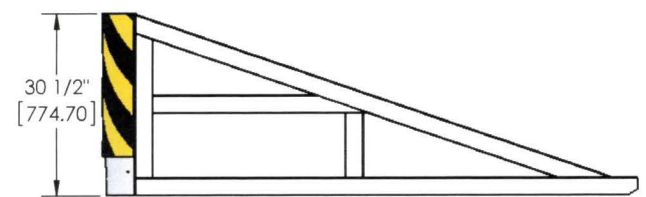
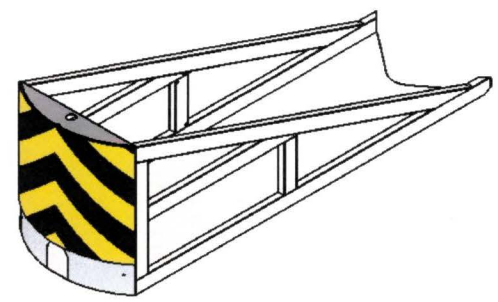
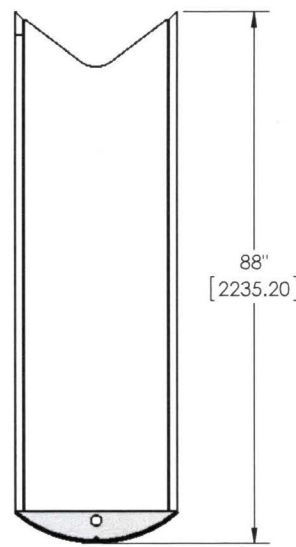
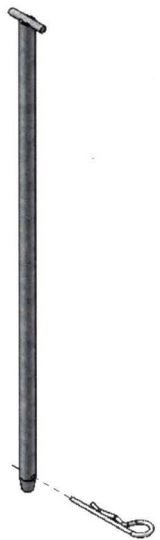
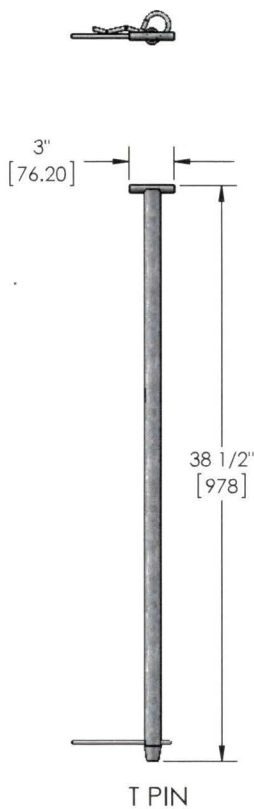

FRONT STEEL CAP

UNITS: INCHES [mm]
MATERIAL: STEEL
NOTES: UNLESS OTHERWISE SPECIFIED

8 7 6 5 4 3 2 1

Traffix Devices Inc.  160 Avenida La Pata
San Clemente, CA 92673
(949) 361-5663
FAX (949) 361-9205
www.traffixdevices.com

TITLE:
**SLED END TREATMENT
HARDWARE**

DRAWN BY: JEREMY SMITH	DATE: 02-09-10	SIZE B	DWG. NO. 300-106	REV H
CHECKED BY: FA	DATE: 10-16-09			
APPROVED BY: FA	DATE: 10-16-09			

SHEET 1 OF 2

8

7

6

5

4

3

2

1

D

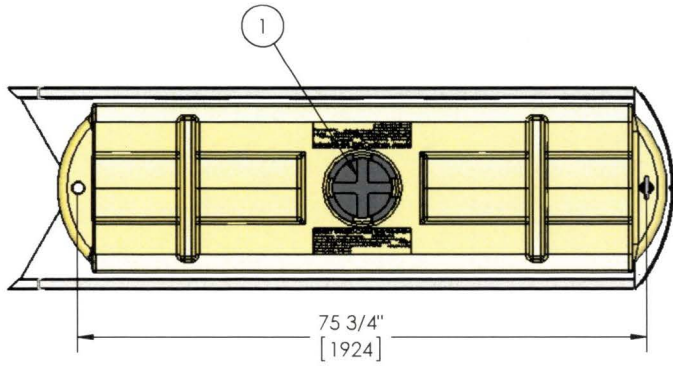

C

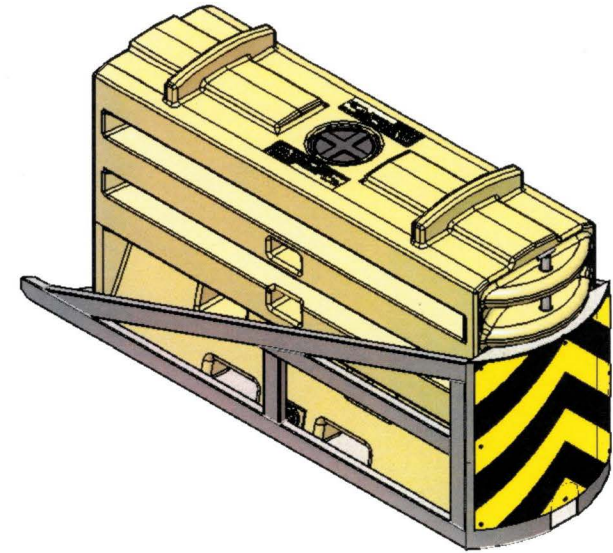

D

B

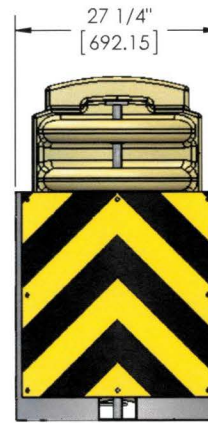
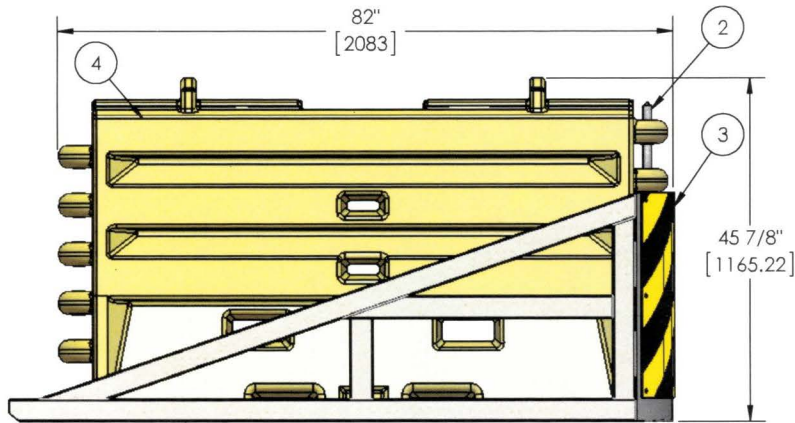

B

A

Traffix Devices Inc.  160 Avenida La Pata
San Clemente, CA 92673
(949) 361-5663
FAX (949) 361-9205
www.traffixdevices.com

TITLE:
**SLED END TREATMENT
PRIMARY ELEMENT**

SIZE **B** DWG. NO. **326** REV **H**

SHEET 1 OF 1

ITEM NO.	DESCRIPTION
1	8" DIA FILL HOLE W/ TWIST LOCK LID
2	CONNECTION STEEL DROP PIN
3	FRONT STEEL SLED
4	SENTRY END TREATMENT

DRAWN BY:
JEREMY SMITH
CHECKED BY:
FA
APPROVED BY:
FA

DATE:
10-16-09
DATE:
10-16-09
DATE:
10-16-09

8

7

6

5

4

3

2

1