

TANGENT LINE PROJECTED FROM THE FACE OF THE LAST TWO POST BLOCKS IN THE STANDARD POST SECTION.

PLAN

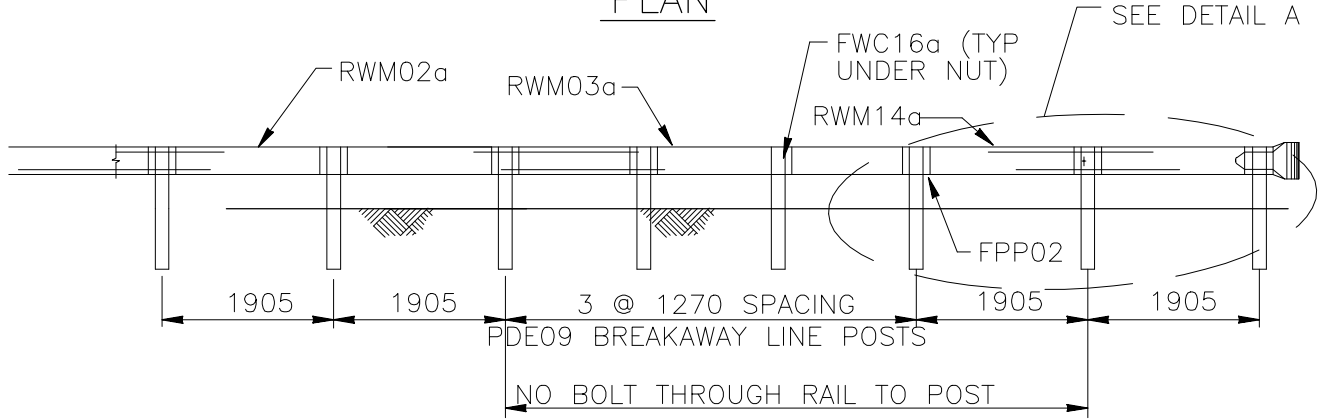

ELEVATION

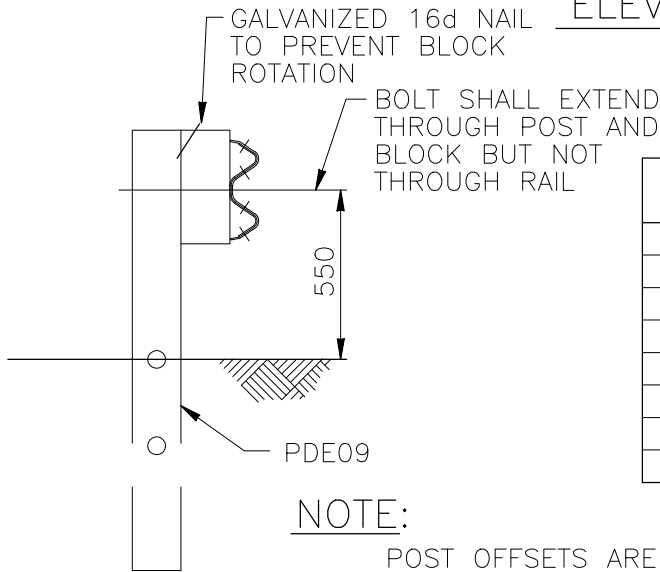

POST	OFFSET FROM TANGENT	POST COMPONENT
1	1220	PDF01
2	635	PDF01
3	355	PDE09
4	200	PDE09
5	100	PDE09
6	65	PDE09
7	25	PDE02
8	0	PDE02

NOTE:

POST OFFSETS ARE GIVEN TO THE CENTER OF THE TRAFFIC FACE OF THE BLOCKOUTS & TO THE CENTER OF THE FIRST POST FACE. OFFSET POINTS ARE TO BE LOCATED BY CHORD MEASUREMENTS AT THE BACK OF RAIL EQUAL TO THE NOMINAL POST SPACINGS SHOWN. POSTS ARE TO BE SET APPROXIMATELY RADIAL TO THE RAILING AT EACH POST LOCATION.

SECTION A-A

1994

MODIFIED ECCENTRIC LOADER BREAKAWAY CABLE TERMINAL

SEW05

SHEET NO.

REF. NO.

1 of 6