

CONCRETE REACTIVE TENSION® BARRIER

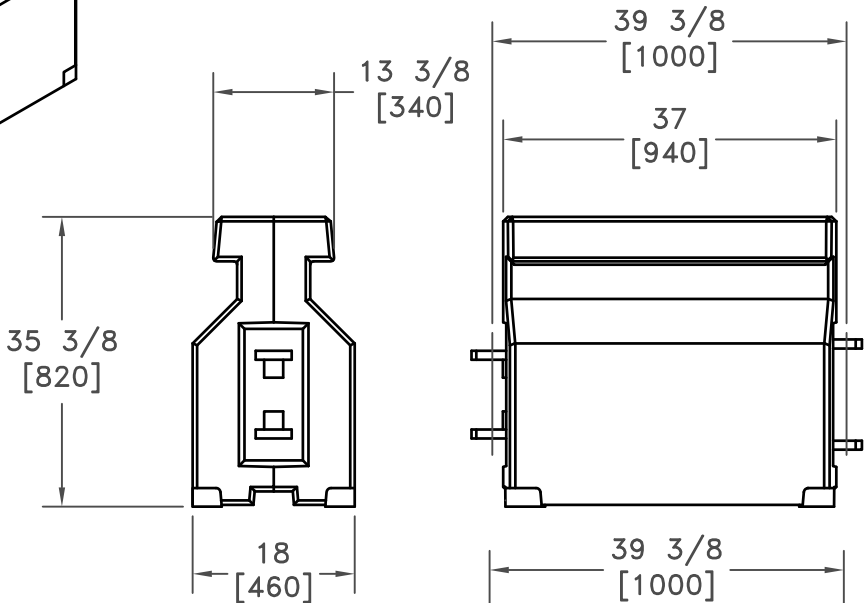

STEEL SHELL REACTIVE TENSION® BARRIER

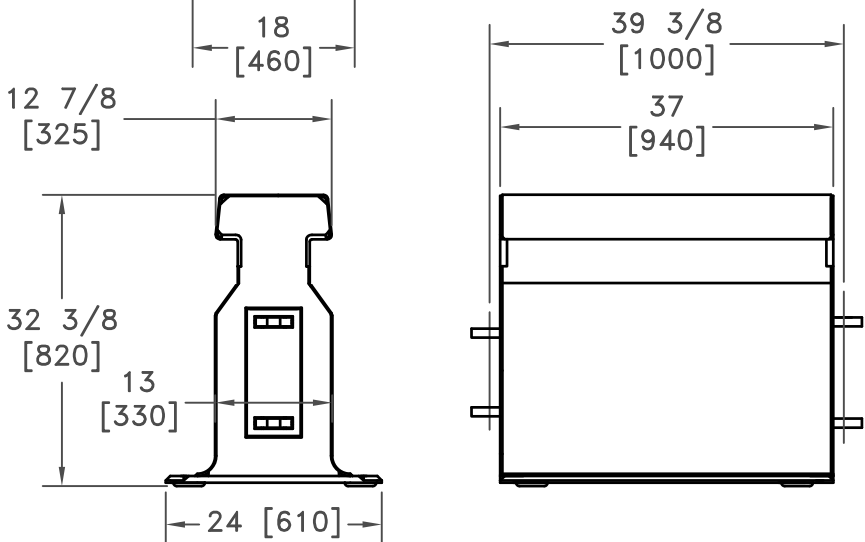

REACTIVE TENSION® MOVEABLE BARRIER, TL-3



Lindsay Transportation Solutions
 180 River Road
 Rio Vista, CA 94571
 Tel: 888-800-3691
 www.barriersystemsinc.com

SGM22

SHEET NO.	DATE:
1 OF 1	06/19/13

INTENDED USE

The Reactive Tension® QuickChange® Moveable Barrier (RTS) system is a NCHRP 350 TL-3 or TL-4 longitudinal barrier capable of rapid lateral transfer by a transfer vehicle. RTS is designed to meet the rigid requirements of deployment in moveable barrier applications where positive separation is required and where lane widths and lateral space are limited. The RTS system has low deflection during vehicle impacts. RTS barriers are either concrete (CRTS) or steel shelled (SRTS).

CRTS is a heavily reinforced concrete barrier connected end to end with tensioning hinge mechanisms and steel pins. Each barrier segment is approximately 39 in [1.0 m] and weighs approximately 1500 lb (680 kg). The barrier is 18 in [460 mm] wide.

SRTS is a steel shelled barrier filled with high strength concrete connected end to end with tensioning hinge mechanisms and steel pins. Each barrier segment is approximately 39 in [1.0 m] and weighs approximately 1600 lb (725 kg). The barrier has a 24 in [610 mm] base and 13 in [330 mm] effective barrier width.

Specially constructed transfer machines are used to lift, move, and reposition the barrier laterally on the roadway. Transfer vehicles are capable of moving the barrier wall up to 24 ft [7.5 m] at up to 10 mph [16 kph] on a permanent system and up to 5 mph [8 kph] for a temporary or construction system.

RTS is used as median barrier on congested roadways to open and close lanes of traffic to adapt to changing traffic volumes during commuting hours or special events. It is also used to open and close construction zones on a periodic basis to increase workspace, safety, reduce congestion, and improve construction worker productivity.

RTS barrier is compatible with the ABSORB 350® Crash Cushion (SC111).

A NCHRP 350 Test Level 4 CRTS Barrier is available (SGM22b)

APPROVALS

The Reactive Tension® QuickChange® Moveable Barrier system has been fully tested in conformance with NCHRP Report 350 Test Level 3 and approved by FHWA.

FHWA Acceptance Letter: HSA-B69, June 27, 2000
HSA-10/B69A, SEPTEMBER 7, 2004
HSA-10/B69B, MARCH 22, 2005
HSA-10/B69D, AUGUST 18, 2011

CONTACT INFORMATION

Lindsay Transportation Solutions
180 River Rd.
Rio Vista, CA 94571
www.barriersystemsinc.com
Phone: 888-800-3691 or 707-374-6800
Fax: 707-374-6801
Email: info@barriersystemsinc.com

REACTIVE TENSION® MOVEABLE BARRIER, TL-3

SGM22

SHEET NO.	DATE:
2 OF 2	06/19/13



Lindsay Transportation Solutions
180 River Road
Rio Vista, CA 94571
Tel: 888-800-3691
www.barriersystemsinc.com