

ELEVATION

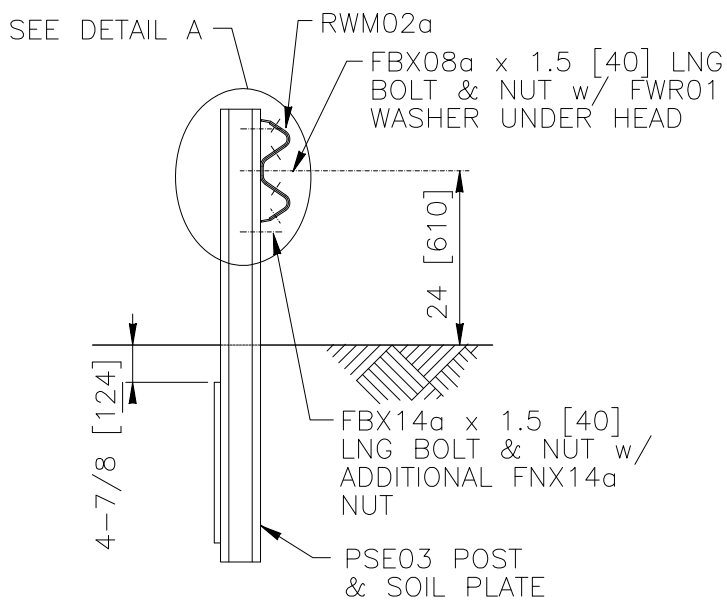

SECTION

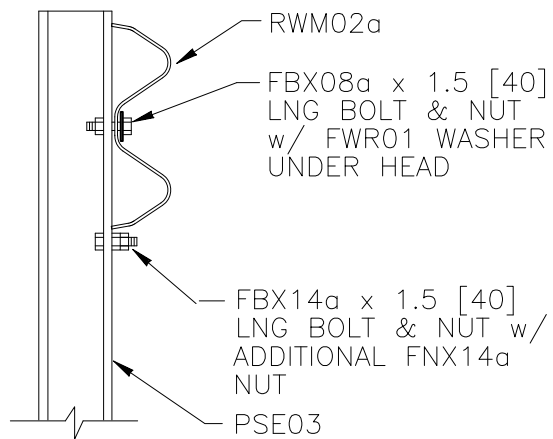

DETAIL A: RAIL-POST ATTACHMENT

1994

WEAK-POST W-BEAM GUARDRAIL



SGR02a

SHEET NO.

DATE:

1 of 2

8/03/2005

INTENDED USE

Weak-post W-beam guardrails are commonly used where dynamic deflections of at least 87 inches [2200 mm] are acceptable. This system must be anchored with a suitable terminal system; crashworthy W-beam terminals can be transitioned to and used with this guardrail system. SGR-02a is a Test Level 2 barrier.

COMPONENTS

Unit length = 150 inches [3810 mm]

Designator	Component	Number
FBB01	Splice bolts and nuts	8
FBX08a	Rail-post bolt (1.5 [40]) and nut	1
FBX14a	Rail support bolt (1.5 [40]) and nut	1
FWR01	Guardrail washer	1
PSE03	Post	1
RWM02a	W-beam rail	1

APPROVALS

FHWA Acceptance Letter B-64.

REFERENCES

M.E. Bronstad, J.E. Michie and J.D. Mayer, Jr., *Performance of Longitudinal Traffic Barriers*, National Cooperative Highway Research Program Report Number 289, Transportation Research Board, June, 1987.

J.D. Michie, L.R. Calcote, and M.E. Bronstad, *Guardrail Performance and Design*, National Cooperative Highway Research Program Report Number 115, Highway Research Board, 1971.

CONTACT INFORMATION

Federal Highway Administration
Office of Safety
400 Seventh Street, SW
Washington, DC 20590
202-366-2288

WEAK-POST W-BEAM GUARDRAIL

SGR02a

SHEET NO.

DATE

2 of 2

07/20/2005

