

IRONWOOD AESTHETIC GUARDRAIL

**WEST ♦ EAST
PARTNERS, LLC**

SGR08a

SHEET NO.

DATE:

1 of 3

7/1/2015

INTENDED USE

Ironwood steel-backed timber guardrail system is designed to provide an aesthetically-pleasing alternative to common roadside barriers. Timber post and rail components of Ironwood present a rustic and natural appearance that blend in with and enhance the surrounding environment along scenic highways. Various timber species, treatment types, and colors are available to provide the desired custom look for a wide range of rural and urban highway locations.

The **Ironwood** steel posts and rail sections provide a safe and strong vehicle barrier that is crash-tested and FHWA-eligible in accordance with NCHRP Report 350, Test Level 3 (TL-3) for longitudinal barriers. The TL-3 performance rating allows Ironwood to be installed as an alternative to many non-aesthetic steel guardrail systems currently in use. In addition, options for end terminal treatments are available to meet individual site conditions.

SYSTEM COMPONENTS

- Steel Post**  S3x5.7 [S75x8] I-Beam with 1/4" [6.35] soil plate.
Wood Post (above grade only): Round, 6-3/4" [171] diameter, routed.
Steel Rail: 4-1/4" [108] x 1/4" [6.35] bent plate channel.
Wood Rail: Round, 8" [203] diameter, routed.
Splice Bar: 1/2" [12.7] x 4-1/2" [114] x 27" [685] steel bar with welded bent plate channel.
Plate Washer: 1/4" [6.3] x 3-1/2" [89] x 10" [254] steel bar.
Saddle Plate: 1/2" [12.7] x 4-1/2" [114] x 12-1/2" [318] steel bar with welded bent plate channel.
*All components and hardware are galvanized after fabrication.



APPROVALS

- Federal Highway Administration (FHWA) Eligibility Letter B-56, June 18, 1999.
Federal Highway Administration (FHWA) Eligibility Letter B-56A, May 11, 2000.
Federal Highway Administration (FHWA) Eligibility Letter B-56B, September 5, 2003.

CONTACT INFORMATION

West - East Partners, LLC
P.O. Box 233, Clinton, NY 13323
Phone: (315) 381-4842 or (406) 363-7554

Email: info@west-eastpartners.com
Web: www.west-eastpartners.com

IRONWOOD AESTHETIC GUARDRAIL

SGR08a

SHEET NO.

DATE

2 of 3

7/1/2015

**WEST ♦ EAST
PARTNERS, LLC**

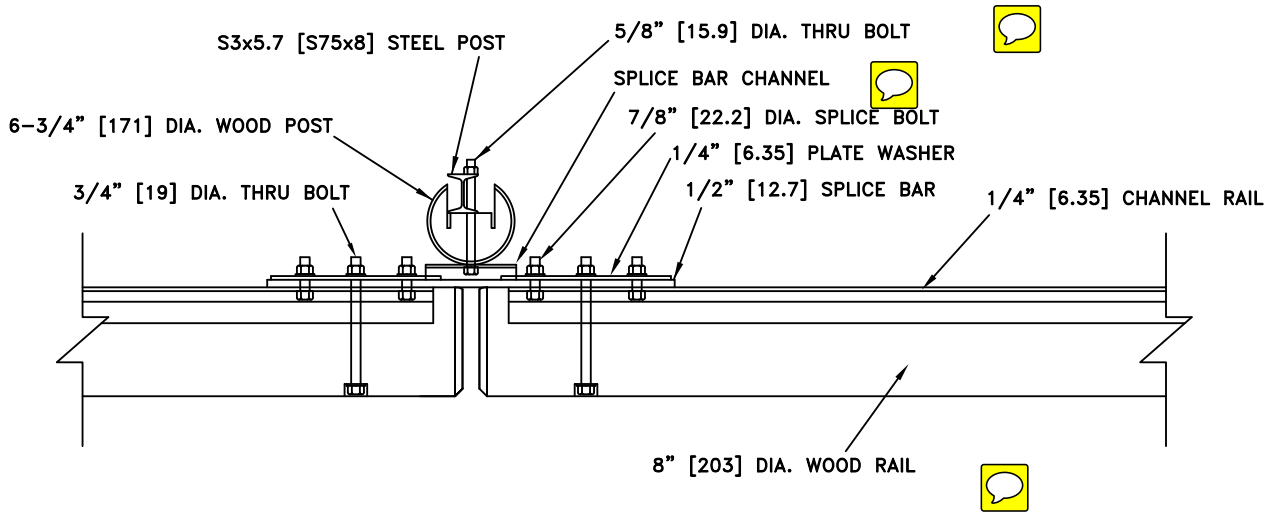

RAIL SPLICE DETAIL

Dimensions are inches [mm] unless otherwise noted.

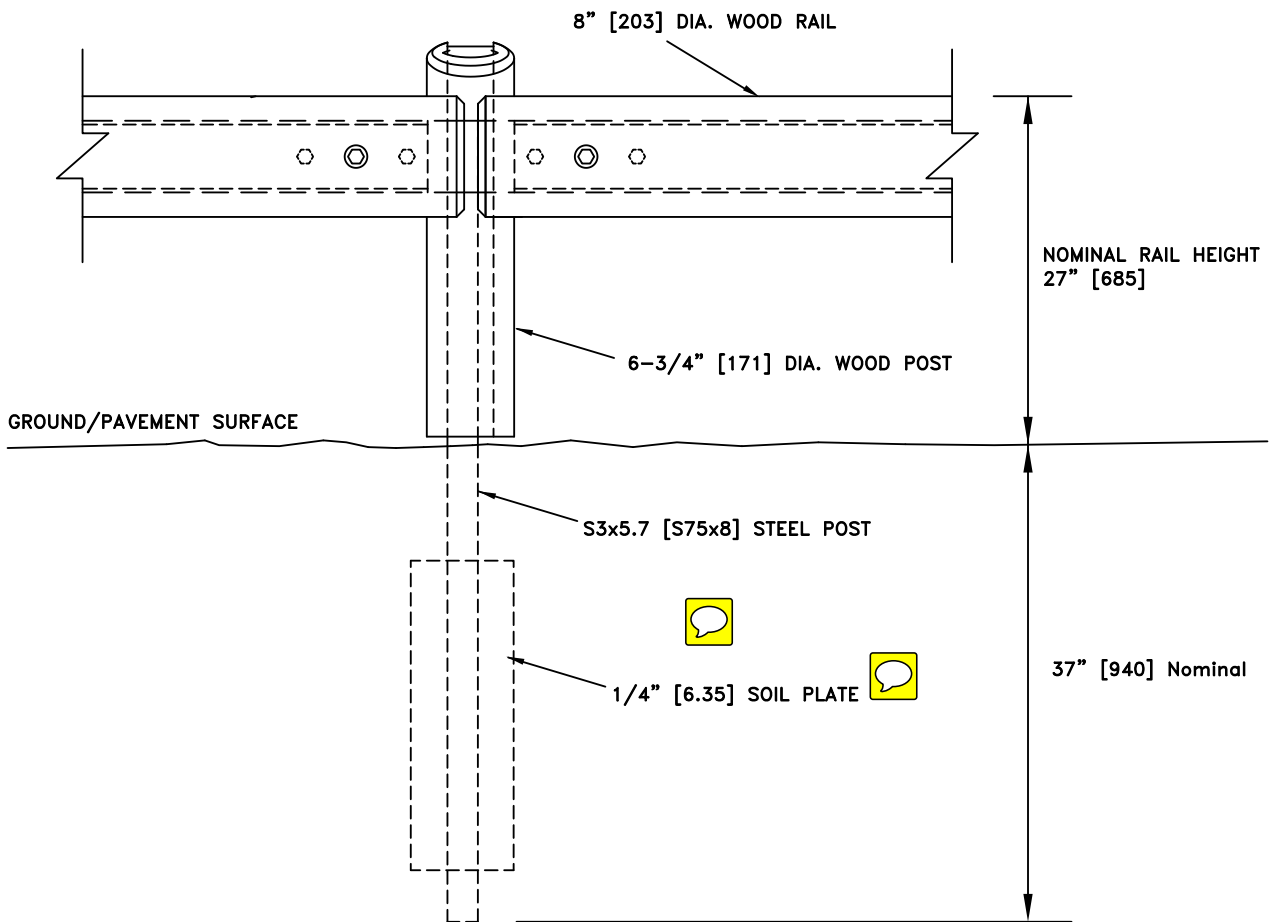

IRONWOOD AESTHETIC GUARDRAIL

**WEST ♦ EAST
PARTNERS, LLC**

SGR08a

SHEET NO.

DATE:

3 of 3

7/1/2015