

INTENDED USE

Ezy-Guard Heavy Duty, a member of the Ezy-Guard family, is a fully compliant MASH TL3 longitudinal guardrail barrier system. It can be used in locations where maximum dynamic deflections of 38 inches [960mm] or less is acceptable. This system must be anchored with a suitable terminal system, ideally a TL3 crashworthy terminal system.

COMPONENTS

Unit length = 157 inches [4000 mm]

Designator	Component	Quantity
10000977	W Beam 4000mm NLL	1
10004121	1800mm HEAVY DUTY Z-POST GALV	2
10004116	HD CARRIAGE	2
10001832	M16 x 30mm Ezy-Guard Post Bolt	2
10001248	M16 x 32 Splice Bolt Grade 8.8	8
10001239	M16 Oversize Nut	8

APPROVALS

FHWA Acceptance Letter [B-229](#), 2/6/2012

REFERENCES

CONTACT INFORMATION

Ingal Civil Products
57-65 Airds Road
Minto
NSW 2566
Australia
+61 2 9827 3333

EZY-GUARD HEAVY DUTY

# (contact Task Force 13 for #)		
SHEET NO.	DATE	
1 of 2	10-04-2013	

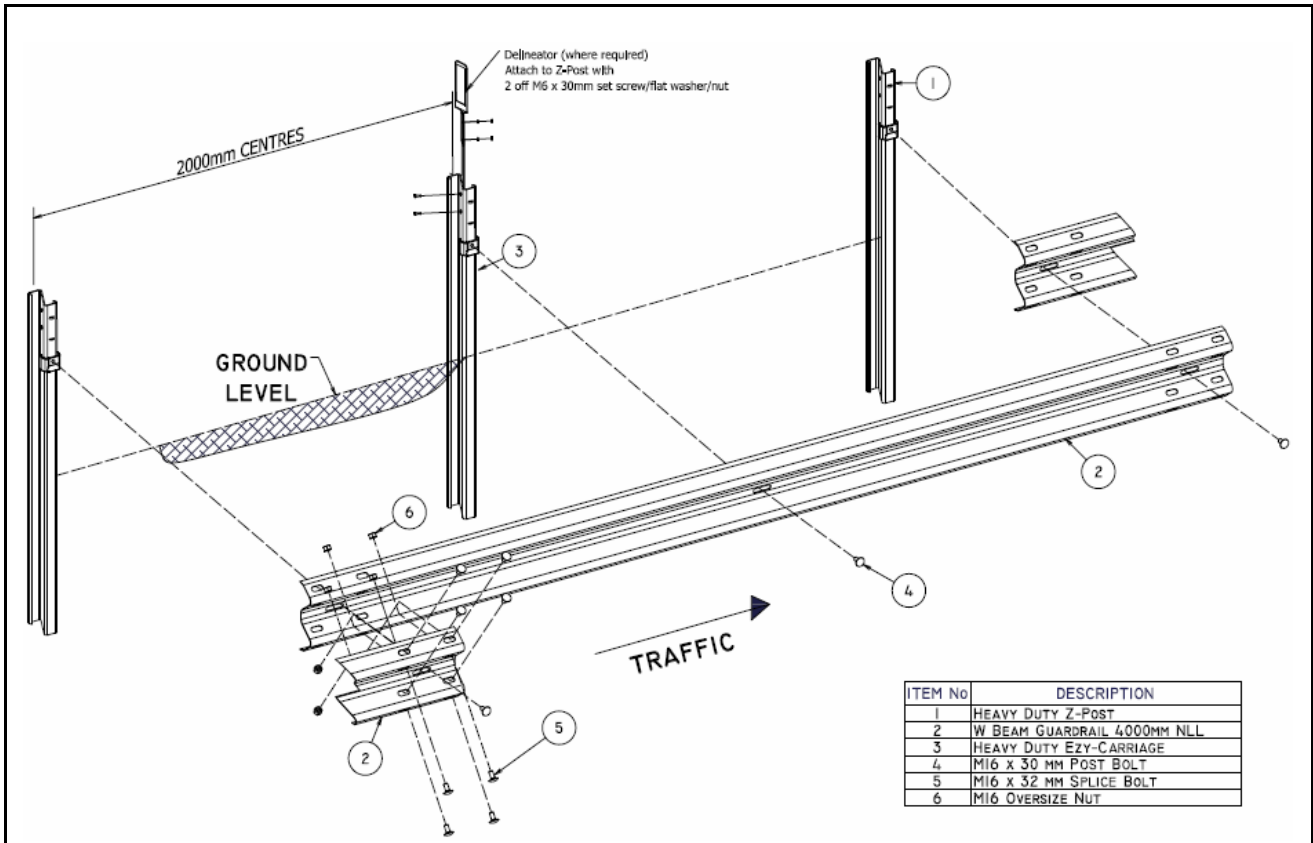

ITEM No	DESCRIPTION
1	HEAVY DUTY Z-POST
2	W BEAM GUARDRAIL 4000MM NLL
3	HEAVY DUTY EZY-CARRIAGE
4	M16 X 30 MM POST BOLT
5	M16 X 32 MM SPLICE BOLT
6	M16 OVERSIZE NUT

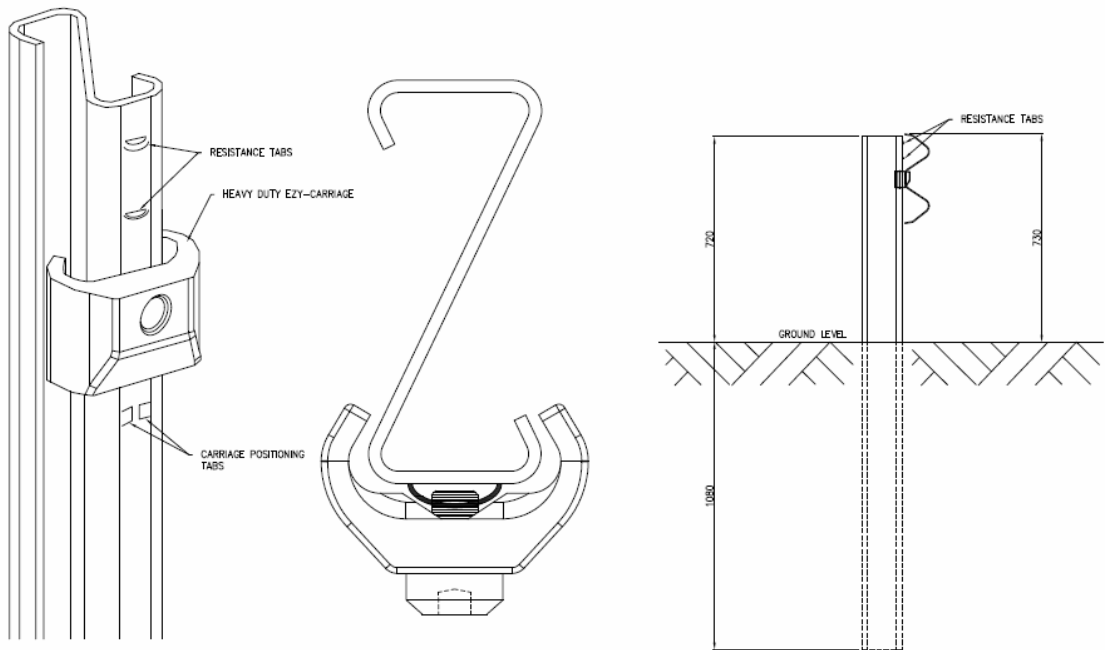

EZY-GUARD HEAVY DUTY

# (contact Task Force 13 for #)	
SHEET NO.	DATE
2 of 2	10-04-2013

