

ITEM No	DESCRIPTION
1	SMART Z-POST
2	W BRAM GUARDRAIL 4000MM NLL
3	SMART EZY-CARRIAGE
4	M16 x 30 MM POST BOLT
5	M16 x 32 MM SPLICE BOLT
6	M16 OVERSIZE NUT

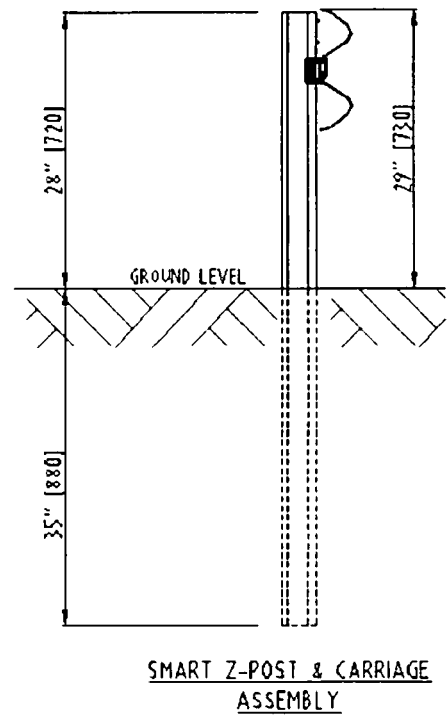
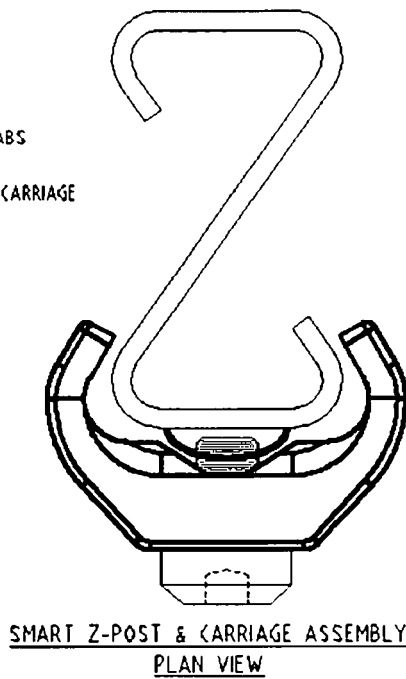
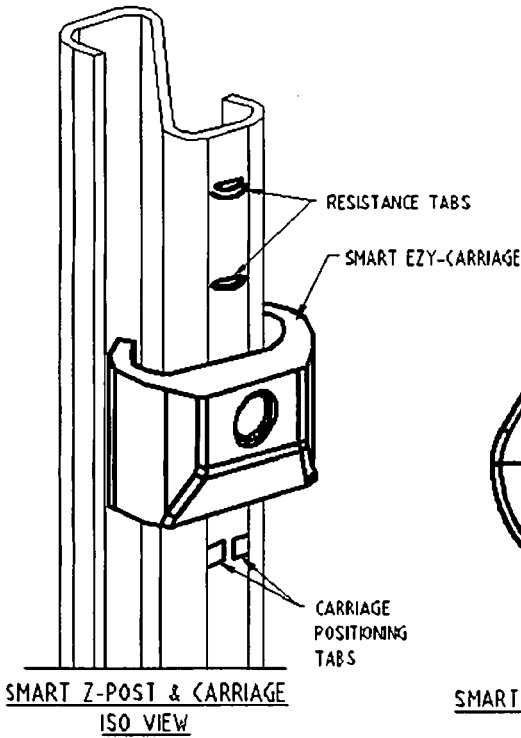

EZY-GUARD SMART

EZY-SM-100

SHEET NO.

DATE

1 of 2

10-29-2013



INTENDED USE

Ezy-Guard Smart, a member of the Ezy-Guard family, is a fully compliant MASH TL3 longitudinal guardrail barrier system. It can be used in locations where maximum dynamic deflections of 65 inches [1650mm] or less is acceptable. This system must be anchored with a suitable terminal system, ideally a TL3 crashworthy terminal system. The Ezy-Guard Smart W-beam longitudinal barrier system consists of W-beam guardrail attached to Ezy-Guard Smart Z-section line post via a guardrail carriage system and attachment bolt. The standard post spacing is 79 inches [2000mm], with 75 inches [1905mm] post spacing an optional alternative.

COMPONENTS

Unit length = 157 inches [4000 mm]

Designator	Component	Quantity
1000977	W Beam 4000mm NLL	1
10004119	1600mm SMART Z-POST GALV	2
10004115	SMART CARRIAGE	2
10001832	M16 x 30mm Ezy-Guard Smart Post Bolt	2
10001248	M16 x 32 Splice Bolt Grade 8.8	8
10001239	M16 Oversize Nut	8

APPROVALS

CONTACT INFORMATION

Ingal Civil Products
57-65 Airds Road
Minto
NSW 2566
Australia
+61 2 9827 3333



EZY-GUARD SMART

EZY-SM-100



SHEET NO.

DATE

2 of 2

10.29.2013