

ELEVATION

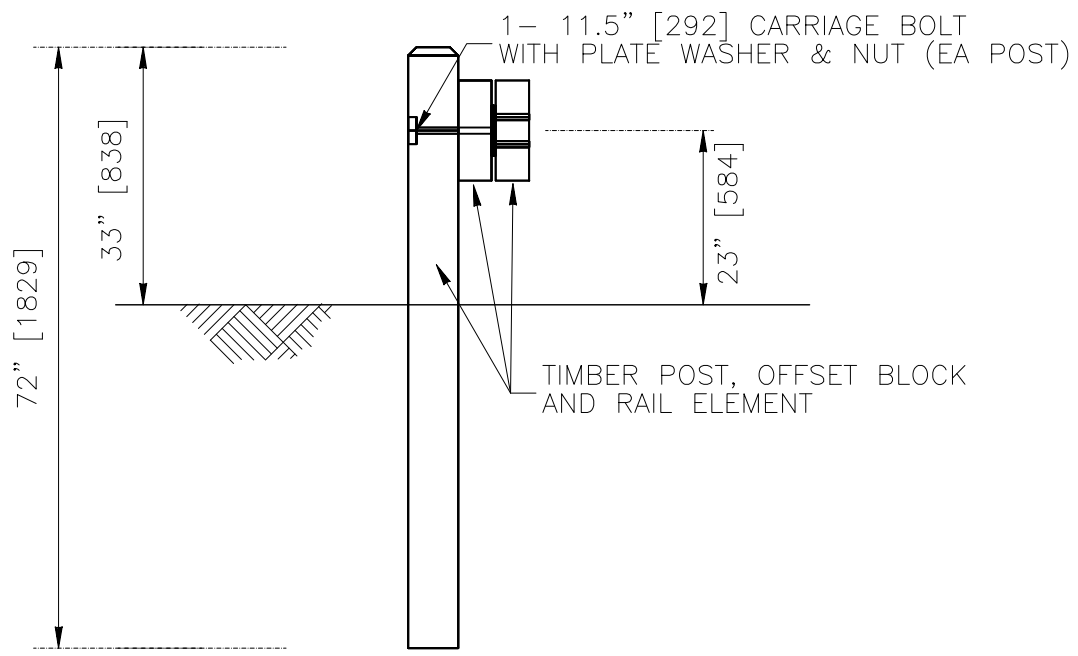

SECTION

TIMBARRIER STREETGUARD PLUS RAIL SYSTEM



SGR65

SHEET NO.	DATE:
1 of 2	07/12/2017

INTENDED USE

The Timbarrier™ Streetguard Plus™ barrier system is an aesthetic wood guardrail system designed for low-speed roads up to 45 mph per NCHRP-350 Test Level 2 criteria. The system is configured to provide active barrier protection from roadside hazards. Design dynamic deflection of the system is 4 ft. 3 in. (1.3m). The barrier may be terminated with a crashworthy anchor system, or a buried-in-back-slope anchor may also be used where appropriate site conditions exist.

ALL TIMBER COMPONENTS SHALL BE:

#1 Grade Southern Pine, S4S, CCA pressure treated in accordance with AWPA Standard C14 to a minimum net retention of 0.60 lbs./cu.ft.

ALL STEEL BACKING AND SPLICE PLATES SHALL BE:

ASTM A588 Weathering Steel

ALL FASTENERS SHALL CONFORM TO THE FOLLOWING SPECIFICATIONS:

Carriage Bolts: ASTM A307 (A242 Weathering)

Nuts: ASTM A563 Type DH3

Washers: ASTM F436 TYPE 3

Lag Screws: ASTM A307

APPROVALS

FHWA Eligibility Letter B-163 - August 30, 2007

REFERENCES

E-Tech Testing Services, Report # 296, Project No. 23-1978, August 2006

CONTACT INFORMATION

S.I. STOREY LUMBER CO., INC.

285 SIKE STOREY ROAD

ARMUCHEE, GA 30105

(706) 234-1605

TIMBARRIER™ STREETGUARD PLUS™ RAIL SYSTEM

SGR65

SHEET NO.

DATE

2 of 2

07/12/2017

