

2014

POZ-LOC YIELDING SIGN SUPPORT SYSTEM



TRINITY
HIGHWAY

SSP10 a-b

SHEET NO.

DATE

1 of 4

6/1/2016

INTENDED USE

The POZ-LOC steel tubular sign support system can be used as a single- (SSP10a) or double-leg (SSP10b) sign support system. These systems can be used as a drivable anchor in strong soil or set in a concrete footing. This system has been judged to meet the requirements of the 1985 AASHTO *Standard Specifications for Structural Supports for Highway Signs, Luminaires and Traffic Signals*.

COMPONENTS

The components of the POZ-LOC steel tubular sign support system include the steel tube post (PTP01 a-b) and the wedge and socket foundation (sheet 3 of 4). The post slides into the socket and is secured in place by the locking wedge. The POZ-LOC drivable socket is manufactured from 0.109 in [2.77 mm] thick ASTM A787 galvanized steel tubing. The material for the precoated steel tubing shall be ASTM A653 with zinc coating conforming to weight designation ASTM A653 G90. The exterior surface shall be coated with a minimum of 12 microns of clear acrylic coating. The POZ-LOC locking wedge shall be manufactured from 0.12 in [3.05 mm] thick ASTM A653 steel sheet with zinc coating weight designation ASTM A653 G210.

APPROVALS

FHWA Acceptance Letter HNG-21/SS-01, May 13, 1986
FHWA Acceptance Letter HNG-21/SS01A, July 14, 1986

CONTACT INFORMATION

2525 North Stemmons Freeway
Dallas, TX 75207
Telephone: (888) 323-6374
Fax: (800) 770-6755
<http://www.highwayguardrail.com/>

POZ-LOC YIELDING SIGN SUPPORT SYSTEM

SSP10 a-b

SHEET NO.

DATE

2 of 4

6/1/2016



TRINITY
HIGHWAY

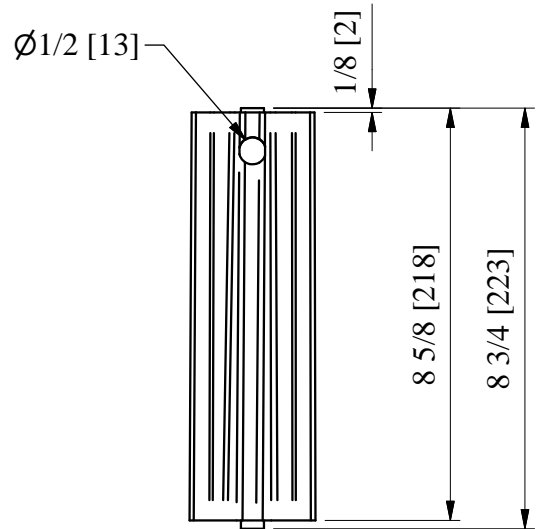
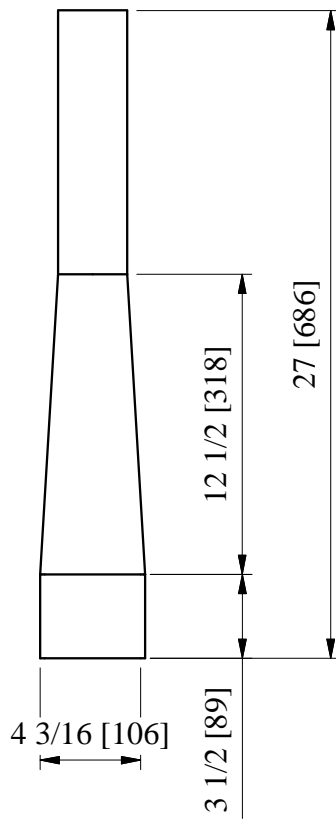
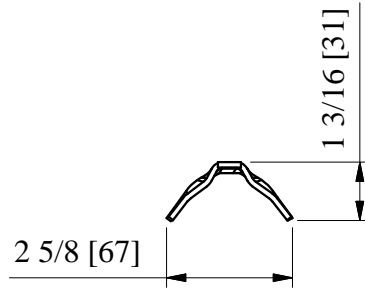
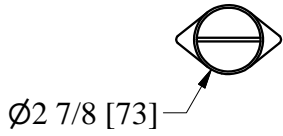

SOCKET

WEDGE

2014

POZ-LOC YIELDING SIGN SUPPORT SYSTEM



TRINITY
HIGHWAY

SSP10 a-b

SHEET NO.

DATE

3 of 4

6/1/2016

This page left blank

POZ-LOC YIELDING SIGN SUPPORT SYSTEM

SSP10 a-b

SHEET NO.

DATE

4 of 4

6/1/2016



TRINITY
HIGHWAY