

# THE SLIP SAFE SUPREME™

## Installation

- 1** Place two Rib-Bak™ posts back-to-back. Make sure to match the ends with holes 1" from the Top. Join them by stitch-bolting them with 5/16-in. hardware (grade 5 or better). Place the first bolt, washer and nut in the 7<sup>th</sup> hole from the Top (casting side), and two more below this in approximately 1 ft. intervals. Tighten the bolts using the turn-of-the-bolt method (1/2 to 3/4 turn after tight, or about 20 ft. lbs.).

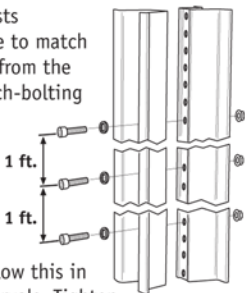

- 2** Install the completed base post assembly into the ground so that no more than 3 in. is above ground level. For direct driving in standard soil, the base post should be at least 1/3 the length of the top post. (If installing in concrete, refer to DOT standards). Before or after you install the post, remove material around the post approximately one ft. deep.

- 3** Assemble the two base post casting sections. First, insert four 1/2-in casting clamping attachment bolts with flat washer through the four edge holes, and place a lock washer and nut on each bolt. Hand-tighten the bolts.

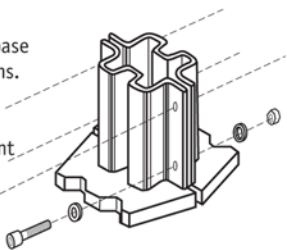

- 4** Place the base post casting assembly over top of the base post. Attach this assembly to the base post by inserting two 5/16-in bolts with washers through the two middle holes of the casting assembly, placing a lock washer and nut on each bolt. Tighten all six of the bolts (from Steps 2 and 3) using the turn-of-the-bolt method. All bolts should be tightened 1/2 to 3/4 turn after snug.

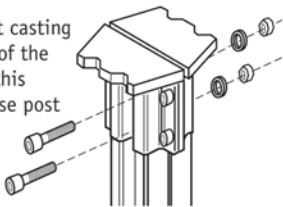

**5** Join two top posts back-to-back by stitch-bolting them with 5/16-in. hardware (grade 5 or better). Place the first bolt, washer and nut in the 7th hole from the bottom (casting side) and repeat approximately every 18 inches for the length of the top post.

**6** Assemble the two top post casting sections exactly the same way as the bottom post sections in Step 3, and join them to the top post in the same manner as Step 4.

**7** Place keeper plate on top of the base post SLIP SAFE SUPREME castings, keeping plate holes aligned to v-notches in castings.

**8** Position the assembled SLIP SAFE SUPREME top post with attached casting over the keeper plate and base post's SLIP SAFE SUPREME casting so that both castings align.

**9** Slip u-bracket over one end of castings. Place a flat washer on the end of the SLIP SAFE SUPREME casting attachment bolt and insert it from the bottom, up through the u-bracket and the keeper plate. Place a second flat washer over the protruding bolt. Put on lock washers and nuts and tighten. Repeat. Using the turn-of-the-bolt method, the attachment nuts should be tightened 1/3 to 1/2 turn after snug. Repeat for other side of casting.

*[Note: This must be a tight fit. Do not worry about "over torquing" of the SLIP SAFE SUPREME casting attachment bolts. The system has been tested with the bolts over torqued.]*

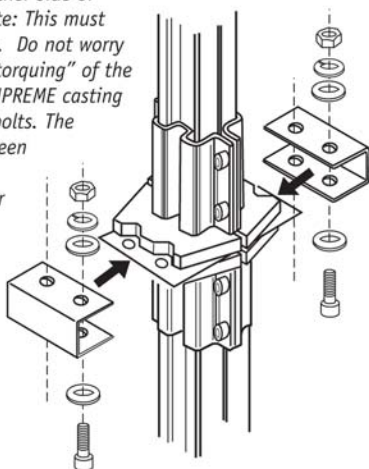

**NUCOR**

**NUCOR STEEL MARION, INC.**