

Panel Length Varies,
as needed.

Retroreflective
Visi-Stripe
(optional)

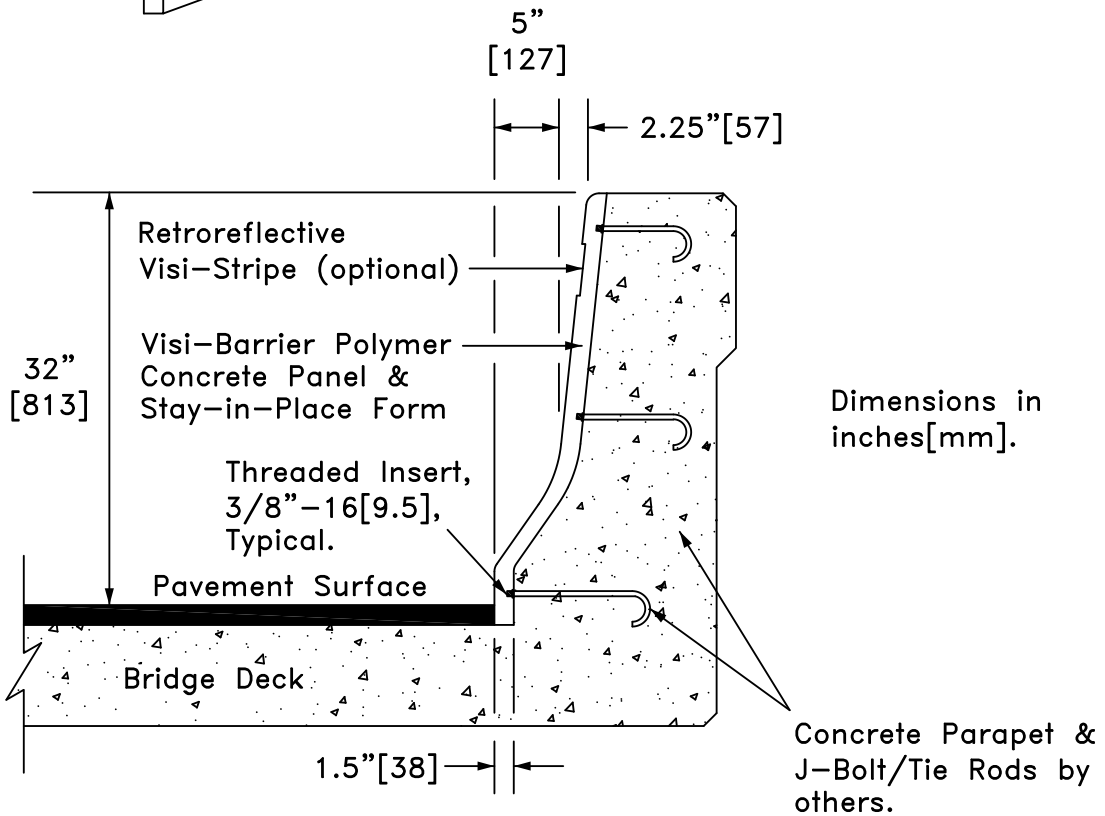

VISI-BARRIER, F-SHAPE, 32" HIGH BRIDGE RAILING

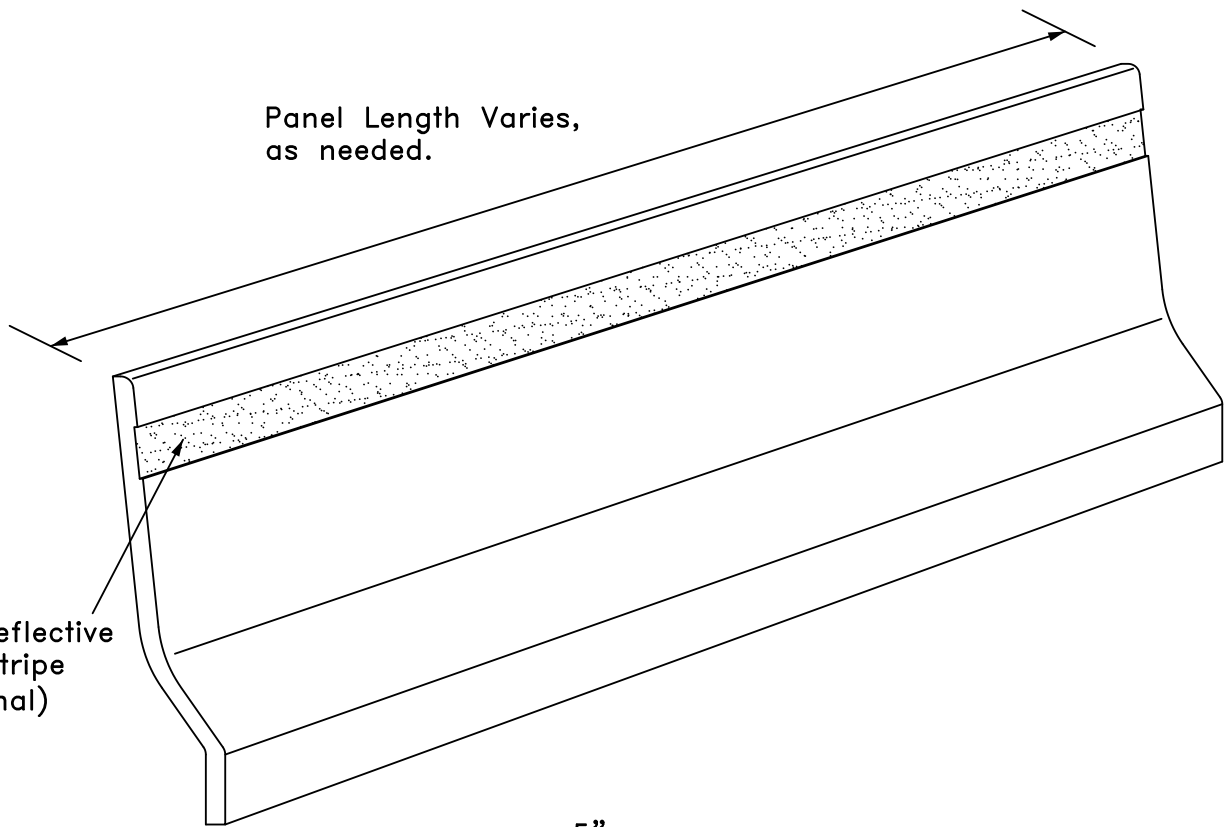

TRANSPPO[®]
INDUSTRIES, Inc.

The Smart Solutions Company

SBC61d

SHEET NO.

DATE:

1 of 2

12/11/2013

INTENDED USE

Visi-Barrier™ is a highly visible, pre-cast polymer concrete bridge railing and tunnel wall liner that also serves a strong stay-in-place form. The continuous visi-stripe on each panel is made from highly retro-reflective glass beads, which solve poor roadway delineation problems, especially on rainy nights when visibility is low. **Visi-Barrier's** polymer concrete provides high compressive and impact strength, a bright white surface, and superior resistance to salts, chlorides, and corrosion.

Visi-Barrier™ is available in standard, as well as modified shapes with various heights and panel lengths to suit specific needs. Designation SBC61d is 32"[813mm] high, standard F-Shape used for new and retrofit bridge railing and tunnel liner applications. The SBC61d barrier height and configuration is accepted as an NCHRP Report 350 Test Level 4 (TL-4) barrier.

PHYSICAL PROPERTIES*

Property	Value	Test Method
Average Compressive Strength	14,000 psi [96 MPa]	ASTM C109
Average Flexural Strength	3200 psi [22 MPa]	ASTM C384
Splitting Tensile Strength	1600 psi [11 MPa]	ASTM D570
Impact Strength	100 ft-lbs [135 N-m]	ASTM D2444
Water Absorption	0.12 - 0.20%	ASTM D570
Fire Resistance	Class "A"	
Flame Spread	<25	ASTM E84
Smoke Development	<75	ASTM E84

*to be used for general guidelines only.

APPROVALS

Federal Highway Administration (FHWA) Acceptance Letter B-64, January 16, 1997.
FHWA Letter from Richard D. Powers to Michael S. Stenko, March 7, 2005.

CONTACT INFORMATION

Transpo Industries, Inc.
20 Jones Street, New Rochelle, NY 10801
Phone: (914) 636-1000
Fax: (914) 636-1282
Email: info@transpo.com
Web: www.transpo.com

VISI-BARRIER, F-SHAPE, 32" HIGH BRIDGE RAILING

SBC61d

SHEET NO.

DATE

2 of 2

12/11/2013

