

10-21 IN. (255-530 MM)
WIDE FLANGE I-BEAM POST

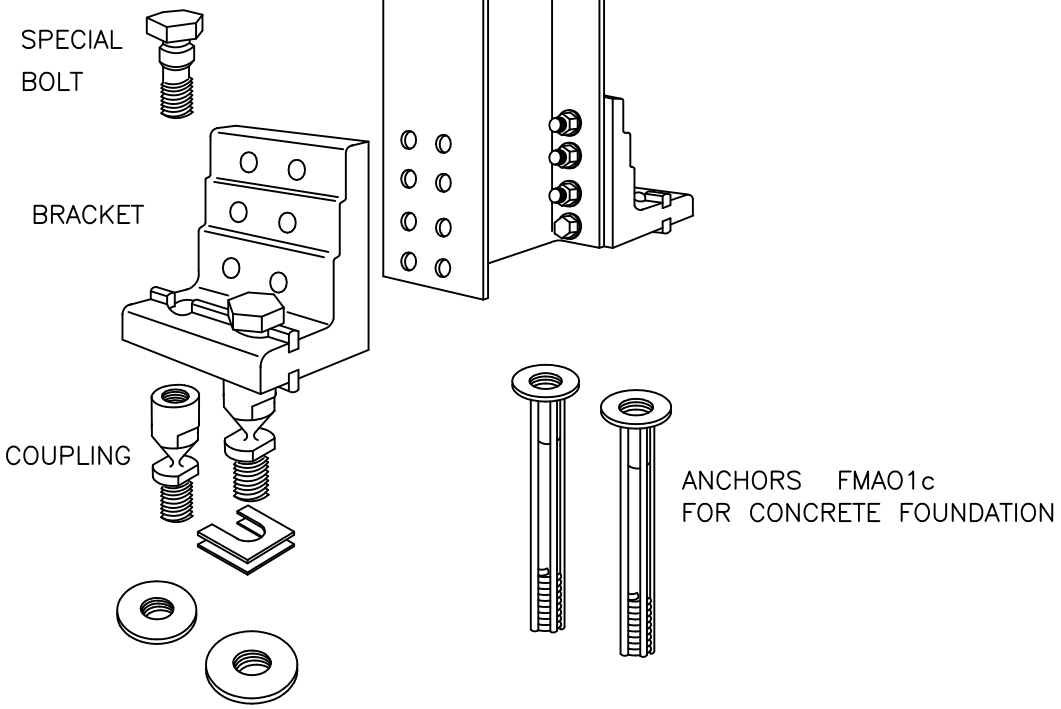

BREAK-SAFE[®] B650 SYSTEM



SSC02a-b	
SHEET NO.	DATE:
1 of 2	05/15/12

SPECIFICATIONS

Break-Safe Model B650 is an omni-directional, bolt-on breakaway system for use with 10-21 in. (255 mm to 530 mm) deep wide flange beams and rectangular steel or aluminum, single (SSC02a) or multiple (SSC02b), ground-mounted sign posts. There is no welding required. The system uses concrete foundations and does not require initial or continued bolt torque maintenance. It is installed flush with the top of the foundation minimizing the possibility of snagging of the vehicle undercarriage.

The system activates when hit from any direction at bumper height causing the frangible couplings and hinges (used only on multi-post signs) to break, usually, without damaging the sign panel or sign posts. This allows for quick and easy re-deployment of the sign by on-site replacement of the frangible components.

The system has been evaluated in accordance with NCHRP Report 350 guidelines and has met or exceeded all requirements of AASHTO Standard Specifications for Structural Supports for Highway Signs, Luminaires and Traffic Signals. It has also been approved by FHWA for use on Federal Aid projects.

NOTE:

Manufacturer's Sign-Post Selection Program is available and recommended for proper post and breakaway system design.

COMPONENTS

<u>Designator</u>	<u>Component</u>	<u>Description</u>	<u>Quantity</u>
FMA01c	Anchor	304 Stainless Steel Ferrule	4
-	Bracket	6061-T6 Extruded Aluminum	2
-	Coupling	AMS 6378F Steel	4
-	Hinge	AISI 4140	4
-	Special Bolt	ASTM A449	4
-	Fasteners	ASTM A325	24
-	Shims	Galvanized Steel Sheet	4
-	Post	By Others	1

REFERENCES

L.A. Staron, Breakaway Sign Supports, Geometrics and Roadside Design Acceptance Letter Number SS-17, Federal Highway Administration, January 8, 1990; SS-17A Federal Highway Administration, March 7, 1995; SS-17B Federal Highway Administration, April 25, 1995.

Michael S. Griffith, Breakaway Sign Supports, Geometrics and Roadside Design Acceptance Letter Number SS-17C, Federal Highway Administration, August 6, 2003.

CONTACT INFORMATION

Transpo Industries, Inc.
20 Jones Street, New Rochelle, NY 10801
Phone: 914-636-1000 Fax: 914-636-1282
Email: info@transpo.com Web: <http://www.transpo.com>

BREAK-SAFE[®] B650 SYSTEM

SSC02a-b

SHEET NO.

DATE:

2 of 2

05/15/12

