

HAWAII 34" AESTHETIC CONCRETE BRIDGE RAIL

SBC70c

SHEET NO.
1 of 5

DATE:
4/20/2020

INTENDED USE

The Hawaii 34" [864] Aesthetic Concrete Bridge Rail is non-proprietary concrete bridge rail that is anchored to a concrete bridge deck with a 2-in. [51] thick concrete or asphalt finishing surface applied on the traffic-side face of the bridge rail. This bridge rail has aesthetic recessed rectangular panels on the traffic-side and back-side surfaces. These aesthetic recessed panels measure 60 in. [1524] wide, 15 in. [381] tall, and ½ [13] in. deep with an inclination angle of 45 degrees. Expansion joints using smooth dowels are typically located at 22-ft [6706] intervals in the bridge rail. End sections measuring 3 ft – 6 in. [1067] long are placed at the end of the bridge rail adjacent to an end buttress structure and should have similar or greater capacity as the bridge rail. The concrete used for the Hawaii 34" [864] Bridge rail should have a minimum nominal compressive strength of 4,000 psi [27.6 MPa]. The Hawaii 34" [864] Aesthetic Concrete Bridge Rail should be used in location where a maximum dynamic deflection of 0.3 in. [8] at the top of the barrier or less is acceptable and where a working width of 17.2 in. [438 mm] is provided. The Hawaii 34" [864] Aesthetic Concrete Bridge Rail should be used with the Modified Hawaii Thrie Beam Approach Guardrail Transition when transitioning to 31" [787] tall strong-post, W-beam guardrail such as Midwest Guardrail System (SGR20). The Hawaii 34" [864] Aesthetic Concrete Bridge Rail has been crash tested under Test Level 3 (TL-3) conditions and deemed crashworthy according to the Manual for Assessing Safety Hardware, Second Edition (MASH 2016) performance criteria.

COMPONENTS

Unit Length = 264" [6706]

DESIGNATOR	COMPONENT	NUMBER
c1	1" [25] Dia. Smooth 24" [610] Long Rebar	3
c2	1 1/4" [32] Dia. PVC Pipe	3
c3	1 1/4" [32] PVC Cap	3
---	Concrete, Minimum 4,000 psi f'c	-
---	See Bill of Bars	-

ELIGIBILITY

Eligibility will be pursued.

REFERENCES

Bielenberg, R. W., Yoo, S., Faller, R. K., and Urbank, E. L., *Crash Testing and Evaluation of the HDOT 34-in. Tall Aesthetic Concrete Bridge Rail: MASH Test Designation Nos. 3-10 and 3-11*, Report to Hawaii Department of Transportation, Transportation Report No. TRP-03-420-19, Midwest Roadside Safety Facility, University of Nebraska-Lincoln, October 2019.

CONTACT INFORMATION

Hawaii Department of Transportation
Aliiimoku Building
869 Punchbowl St.
Honolulu, HI 96813

HAWAII 34" AESTHETIC CONCRETE BRIDGE RAIL

SBC70c

SHEET NO.

DATE:

2 of 5

4/20/2020

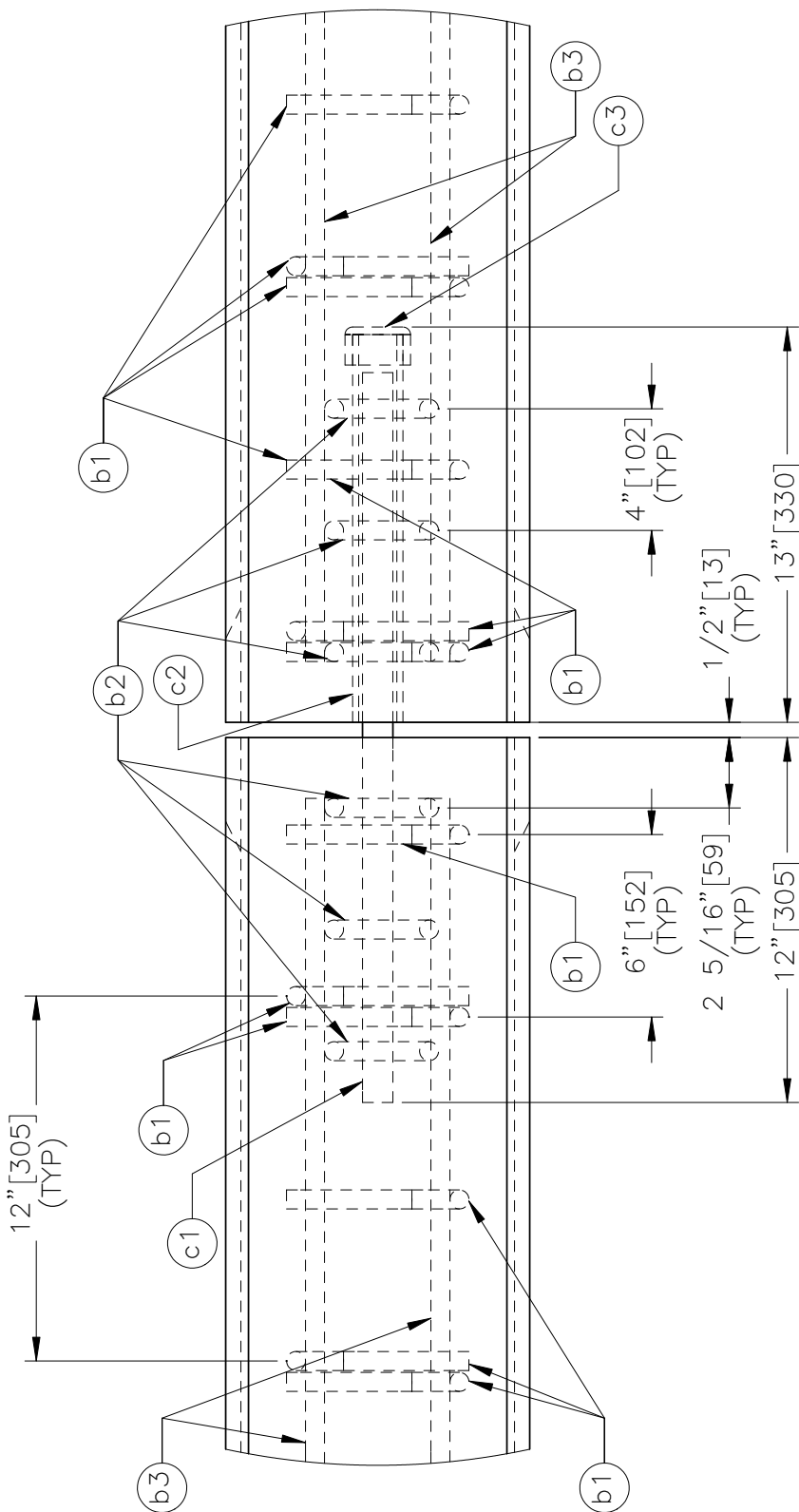

DETAIL C

NOTE: SMOOTH DOWELS ARE CAST IN PLACE ON ONE SIDE OF THE EXPANSION JOINT, AND INSERTED INTO PLASTIC SLEEVES, WHICH ARE CAST INTO THE BARRIER ON THE OTHER SIDE OF THE EXPANSION JOINT.

HAWAII 34" AESTHETIC CONCRETE BRIDGE RAIL

SBC70c

SHEET NO.

DATE:

3 of 5

4/20/2020

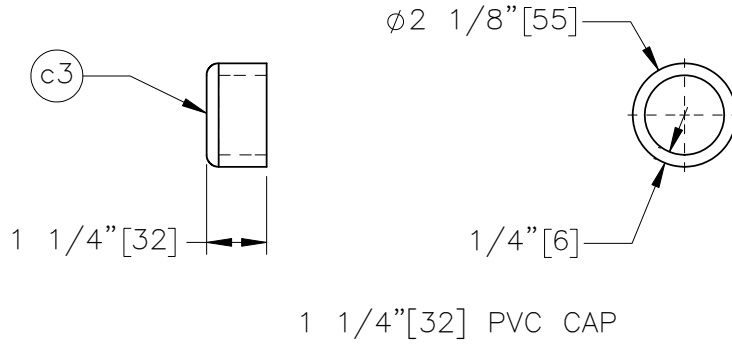
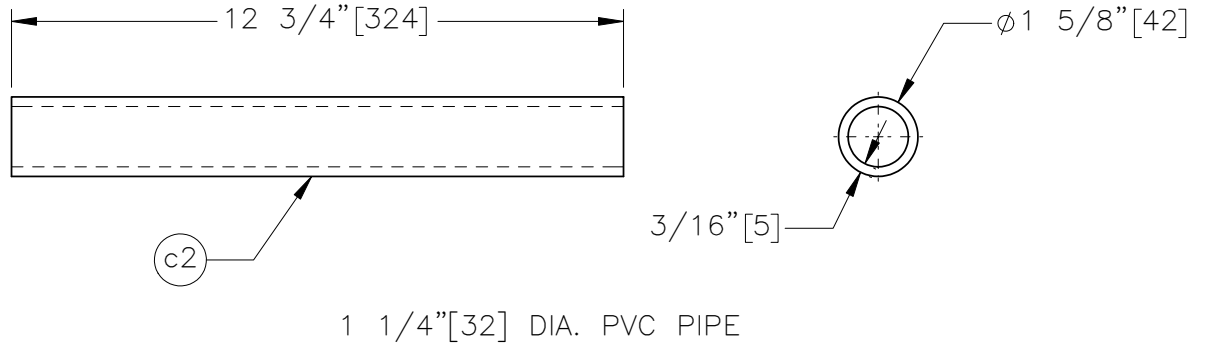
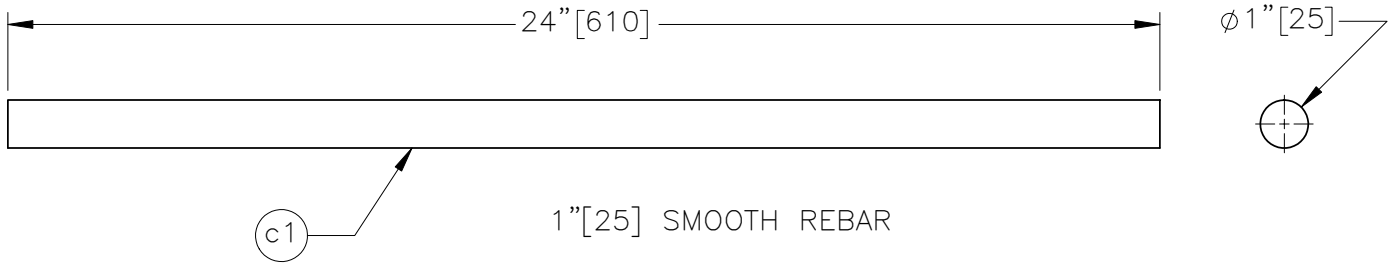

HAWAII 34" AESTHETIC CONCRETE BRIDGE RAIL

SBC70c

SHEET NO.

DATE:

4 of 5

4/20/2020

BILL OF BARS				
Part No.	Bar No.	No.	Unbent Length	Material
b1	#5	68	46 3/4" [1187]	ASTM A615 Gr. 60
b2	#5	6	38 7/8" [987]	ASTM A615 Gr. 60
b3	#5	8	259 1/2" [6591]	ASTM A615 Gr. 60

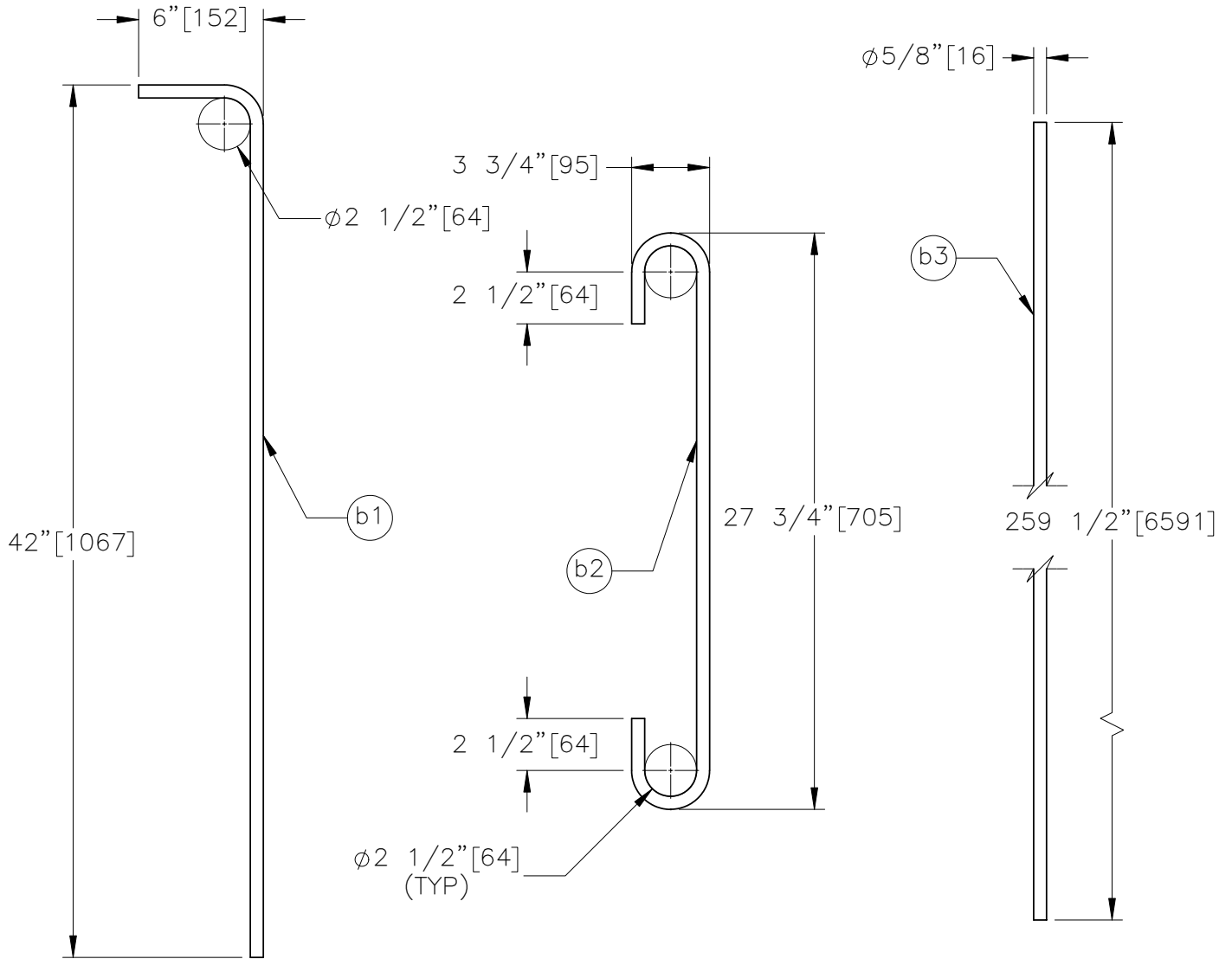

HAWAII 34" AESTHETIC CONCRETE BRIDGE RAIL

SBC70c

SHEET NO.

DATE:

5 of 5

4/20/2020