

NOTE:  
INSTALL SoftStop® PARALLEL TO ROADWAY.  
WHEN OFFSET IS REQUIRED BY DESIGN ENGINEER,  
SEE SoftStop® (8" COMPOSITE BLOCKS) MANUAL FOR  
REQUIREMENTS.

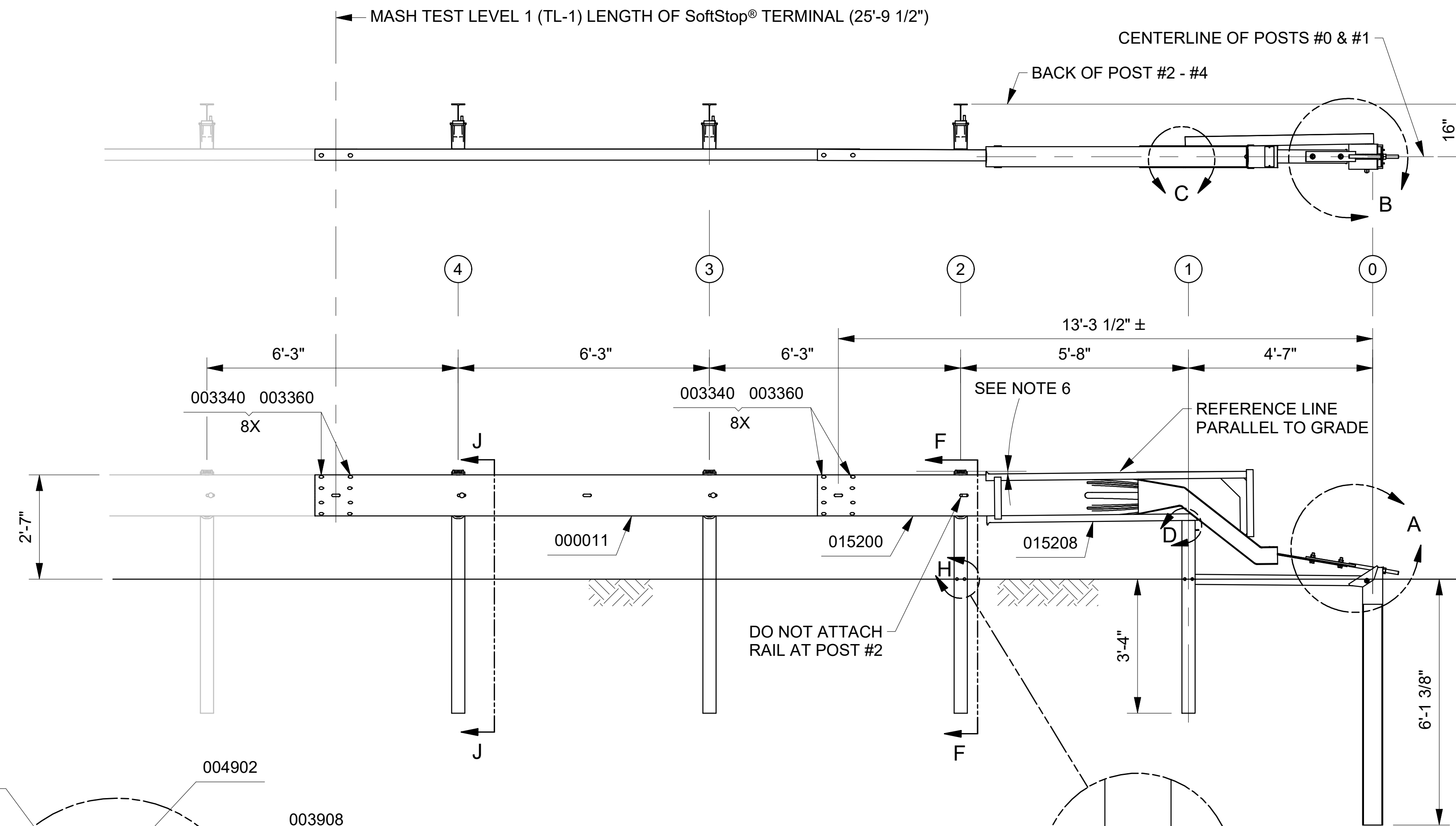

PARTS LIST		
PART NO.	QTY.	DESCRIPTION
000011	1	12/12'6/3'1.5/S
000533	2	6'-0" POST / W 6X8.5#
VARIOUS	3	8" COMPOSITE BLOCK
015000	1	6'0 SYT PST/8.5/31" GR HT
015200	1	SFST-ANCHOR G.RAIL 12'-6"
015202	1	SFST-ANGLE STRUT
015203	1	SFST-POST#1 SYTP
015204	1	SFST-ANCHOR PADDLE
015205	1	SFST-POST#0
015208	1	SFST-IMPACT HEAD
HARDWARE KIT 034428		
003240	6	5/16 ROUND WASHER WIDE
003245	3	5/16" HEX NUT
003340	21	NUT, HX, 5/8, G, RAIL
003360	16	5/8" X 1.25" GR BOLT
003391	1	5/8" X 1.75" HEX BOLT A325
003500	3	5/8" X 10" GR BOLT A307
003701	4	3/4" ROUND WASHER F436
003704	2	3/4" HVY HEX NUT A563 DH
003717	2	3/4" X 2.5" HEX BOLT A325
003908	1	1" HVY HEX NUT A563 DH
004372	4	5/8" WASHER F436
004489	1	5/8" X 9" HEX BOLT A325
004902	1	1" ROUND WASHER F436
105285	2	5/16" X 2.5" HEX BOLT GRD 5
105286	1	5/16" X 1.5" HEX BOLT GRD 5
015201	2	SFST-ANCHOR ANGLE
015206	1	SFST-PLATE WASHER
015207	1	SFST-KEEPER PLATE

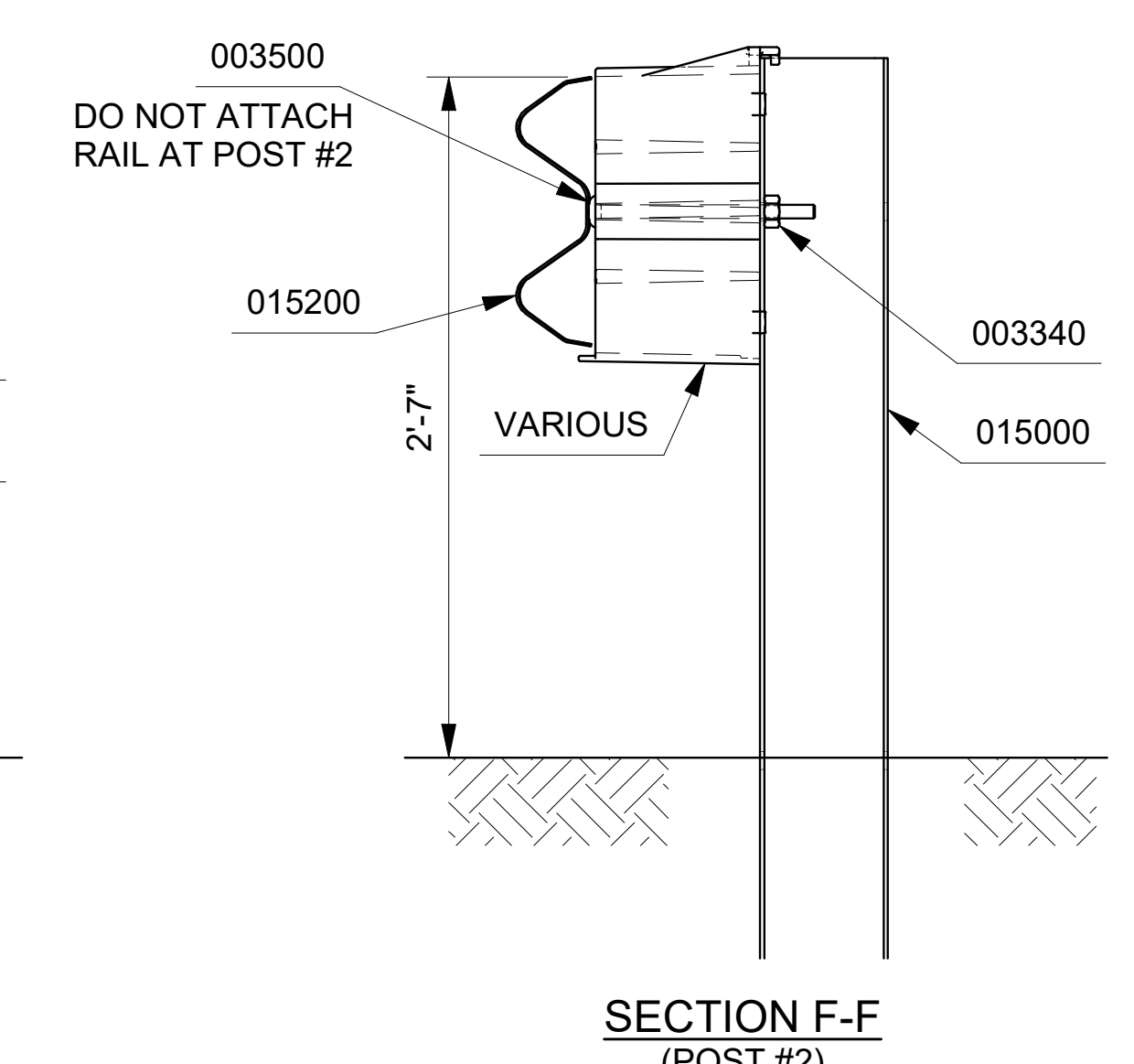
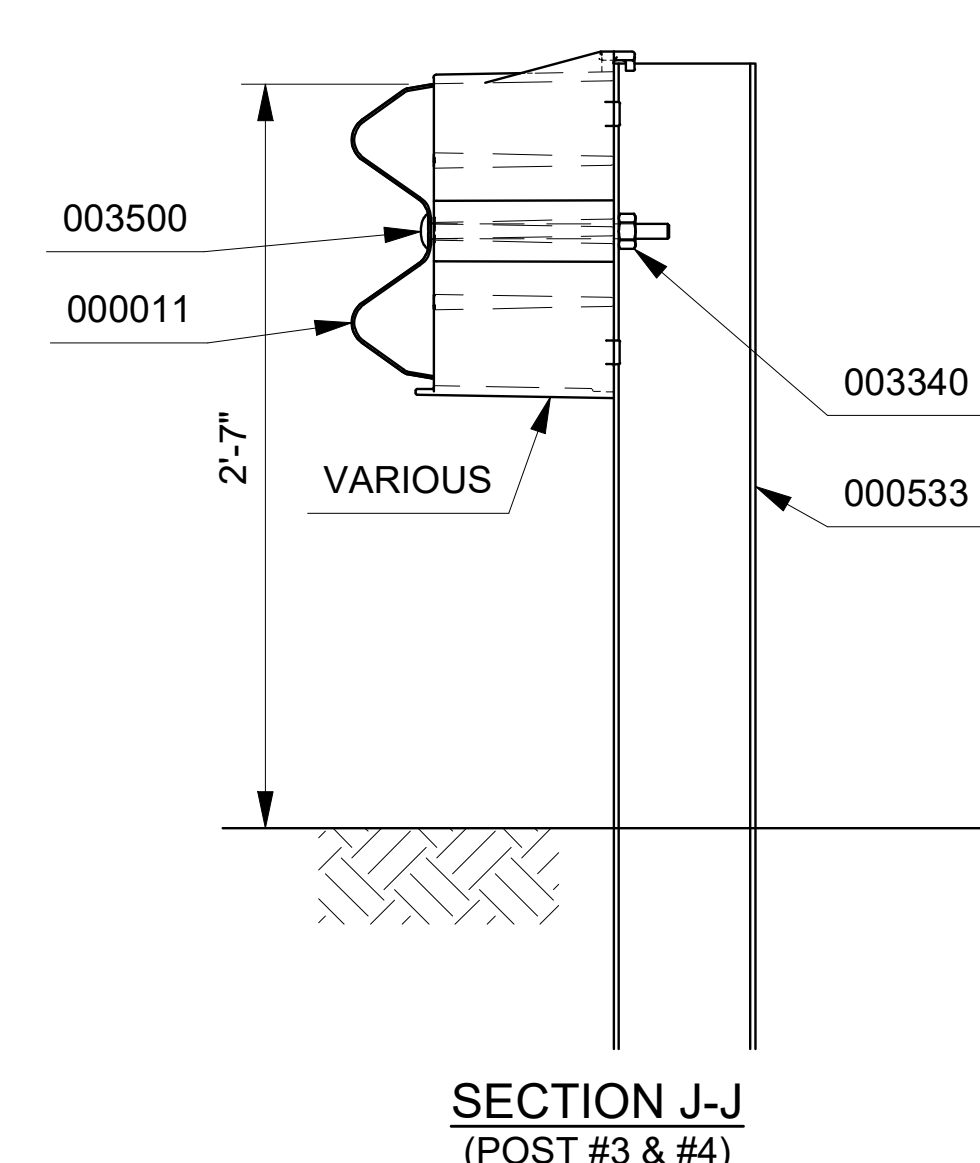
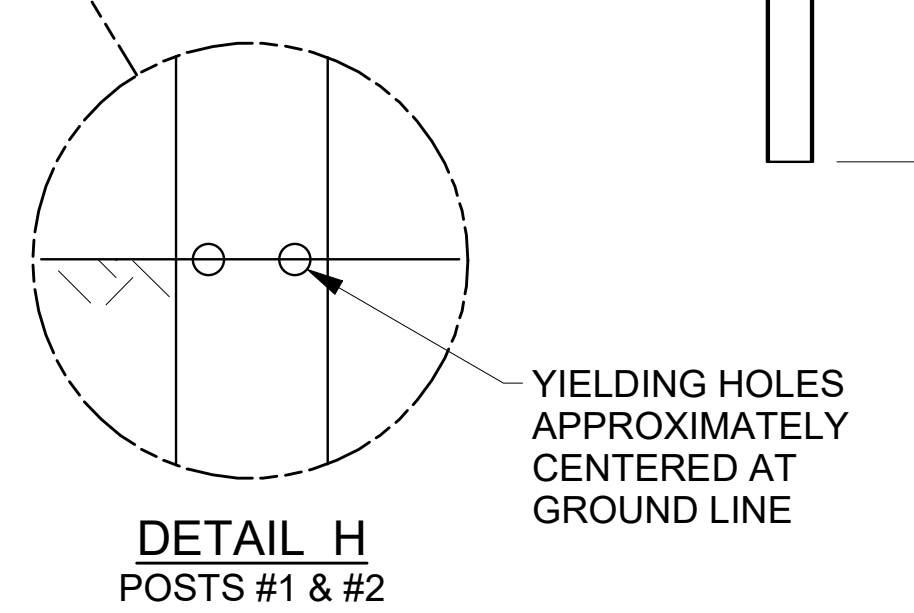
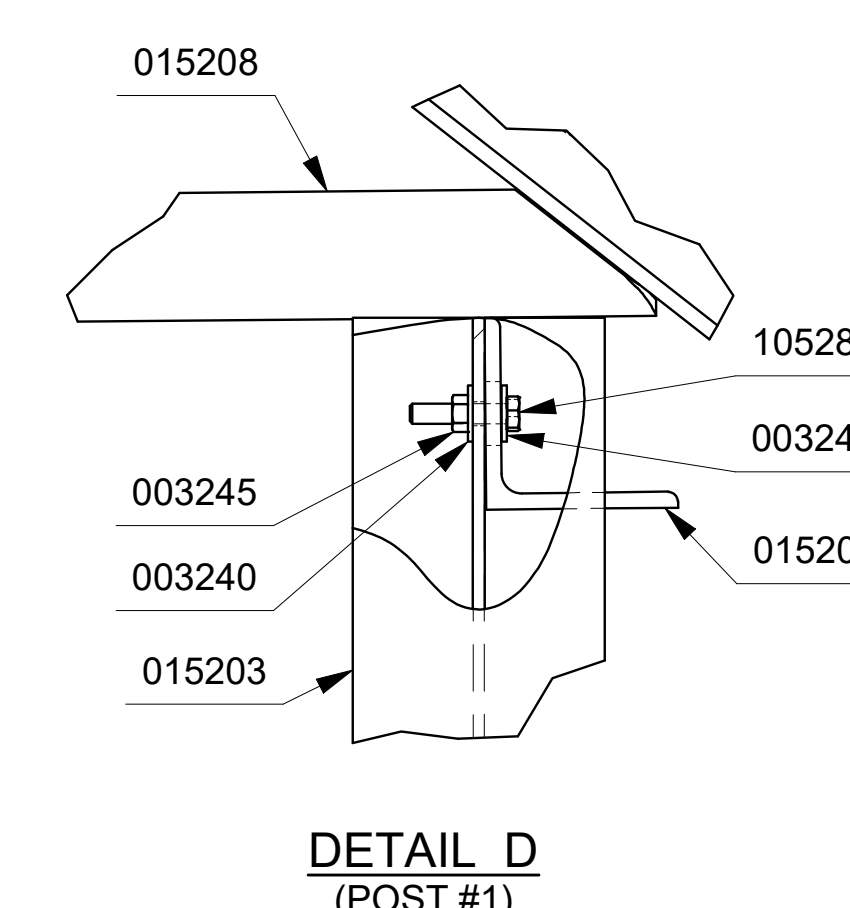
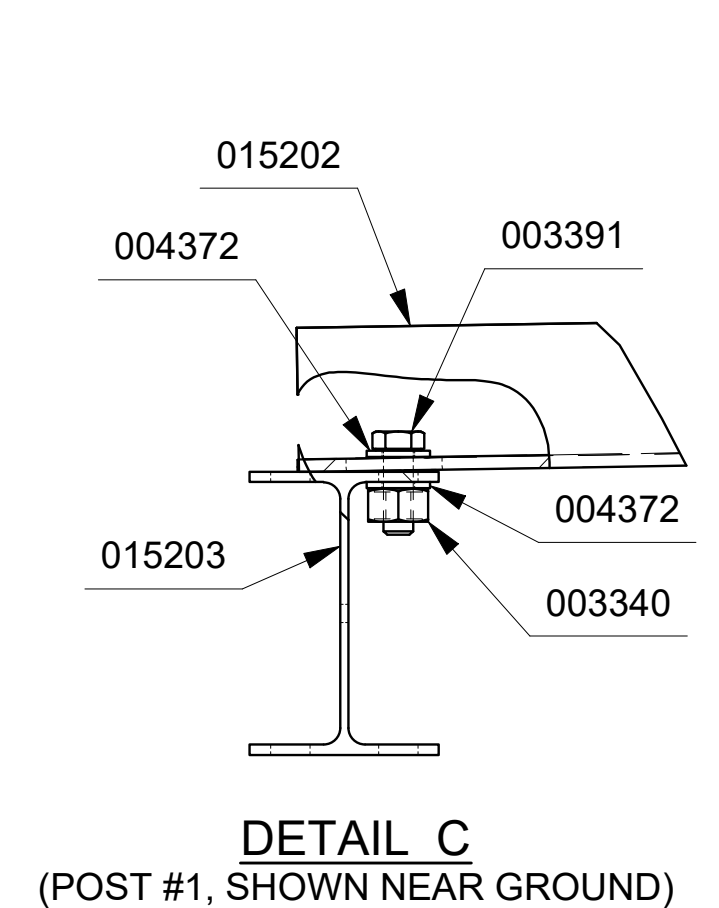
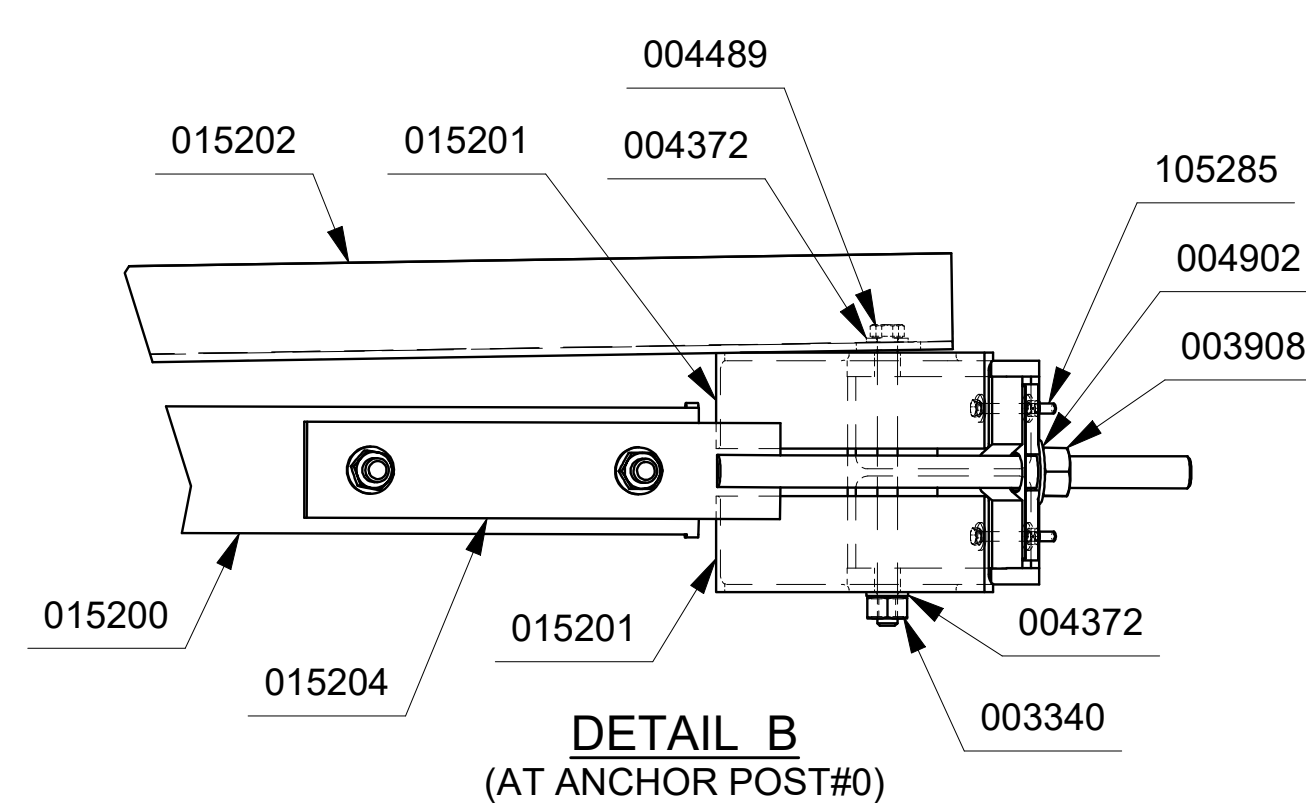
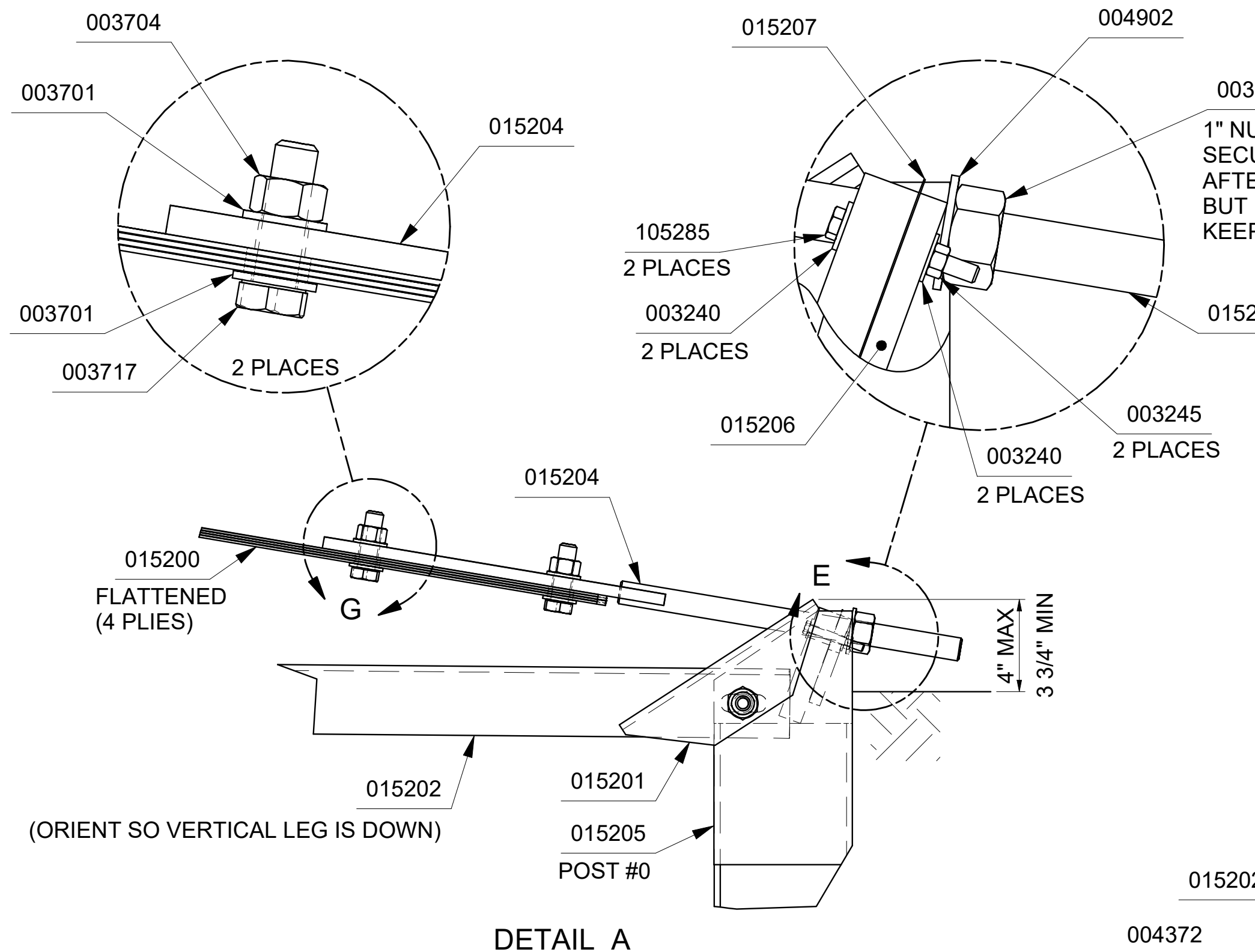

NOTES:

- REFER TO SoftStop® (8" COMPOSITE BLOCKS) ASSEMBLY MANUAL.
- PROPER SITE GRADING SHOULD BE ACCOMPLISHED IN ACCORDANCE WITH LOCAL SPECIFYING AGENCY GUIDELINES AND THE AASHTO ROADSIDE DESIGN GUIDE.
- DO NOT ATTACH THE SoftStop® DIRECTLY TO A RIGID BARRIER.
- UNDER NO CIRCUMSTANCES SHALL THE GUARDRAIL WITHIN THE SoftStop® BE CURVED.
- MANUFACTURER SUGGESTS CUSTOMER TO PROVIDE REFLECTORIZATION OF THE TERMINAL.
- IT IS ACCEPTABLE TO INSTALL THE SoftStop® IMPACT HEAD PARALLEL TO THE GRADE LINE OR WITH AN UPWARD TILT. SEE SoftStop® ASSEMBLY MANUAL FOR SPECIFIC DETAILS.

DRAWN: LH	DATE: 1/14/2013	MODEL: TL-1 / 8" BLOCK / 12'6"			
CHECKED: BS	DATE: 1/14/2013	TRAFFIC DIRECTION: UNIDIRECTIONAL			
UNLESS OTHERWISE NOTED, DIMENSIONS ARE IN MILLIMETERS (INCH). DIMENSIONS ACCORDING TO ASME Y14.5-2018 AND QMS-SE-003 UNLESS OTHERWISE SPECIFIED.					
REVISION DESCRIPTION	ECO	DATE	REV	BY	CHK
ADDED CALLOUTS FOR BOLTS & NUTS AT SPLICES	4844	6/21/17	4	DDS	KWL
ADDED 8" COMPOSITE BLOCKS TO NOTES & MOVED 015201, 015206 & 015207 TO HDWR KIT	6641	8/1/19	E	DDS	PLK
UPDATE BORDER	8261	10/18/21	F	JM	KWL

SoftStop® TERMINAL (8" BLOCKS)  
PLAN, ELEVATION & SECTION  
MASH TEST LEVEL 1 (TL-1)  
P/N: 500654

