

THE CROSS-SECTIONAL DIMENSIONS FOR THIS PART ARE THE SAME AS PART RWM02a-b (SHT 3 of 3).

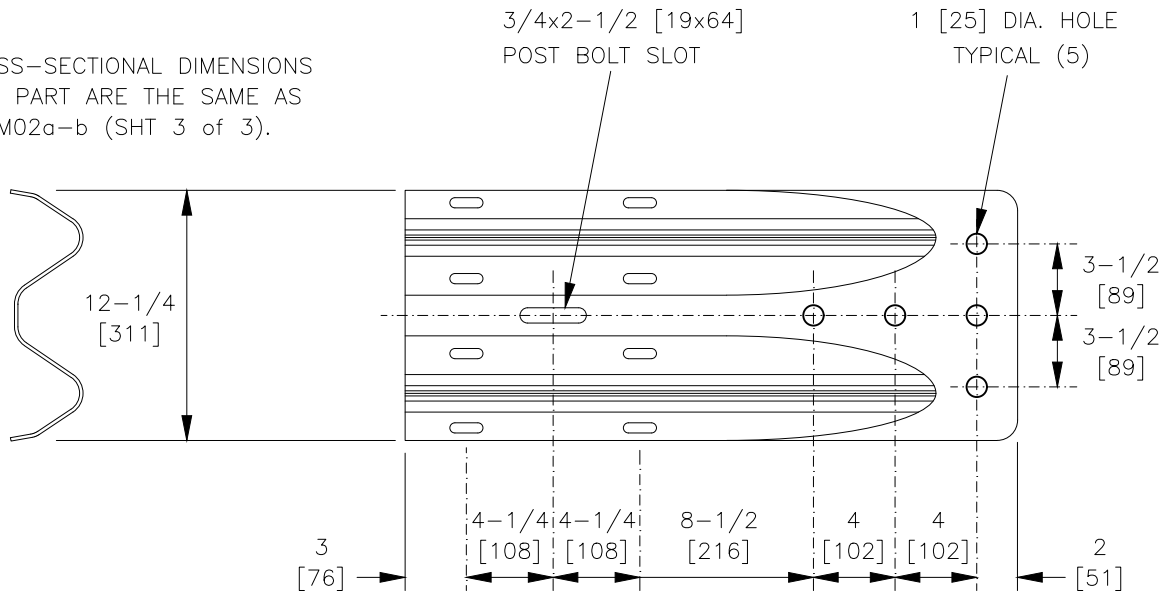

DESIGNATOR	BASE METAL THICKNESS
RWE02a	12 Gage [2.67]
RWE02b	10 Gage [3.43]

W-BEAM TERMINAL CONNECTOR



RWE02a-b

SHEET NO.	DATE
1 of 2	4/18/2024

SPECIFICATIONS

W-Beam Terminal Connectors shall conform to the current requirements of AASHTO M180. RWE02a shall conform to AASHTO M180 Class A, and RWE02b shall conform to Class B.

Dimensional tolerances not shown or implied are intended to be those consistent with the proper functioning of the part, including its appearance and accepted manufacturing practices.

INTENDED USE

RWE02a-b Terminal Connectors are used in various W-Beam guardrail systems.

CONTACT INFORMATION

Task Force 13 (TF13)
a Non-Profit Association
<https://TF13.org>

W-BEAM TERMINAL CONNECTOR

RWE02a-b



SHEET NO.

DATE

2 of 2

4/18/2024