

29/32x1-1/8 [23x29]
SPLICE BOLT SLOT (TYP)

THE CROSS-SECTIONAL DIMENSIONS
FOR THIS PART ARE TO FIT OVER
PART RWM02a (Sheet 3 of 3).

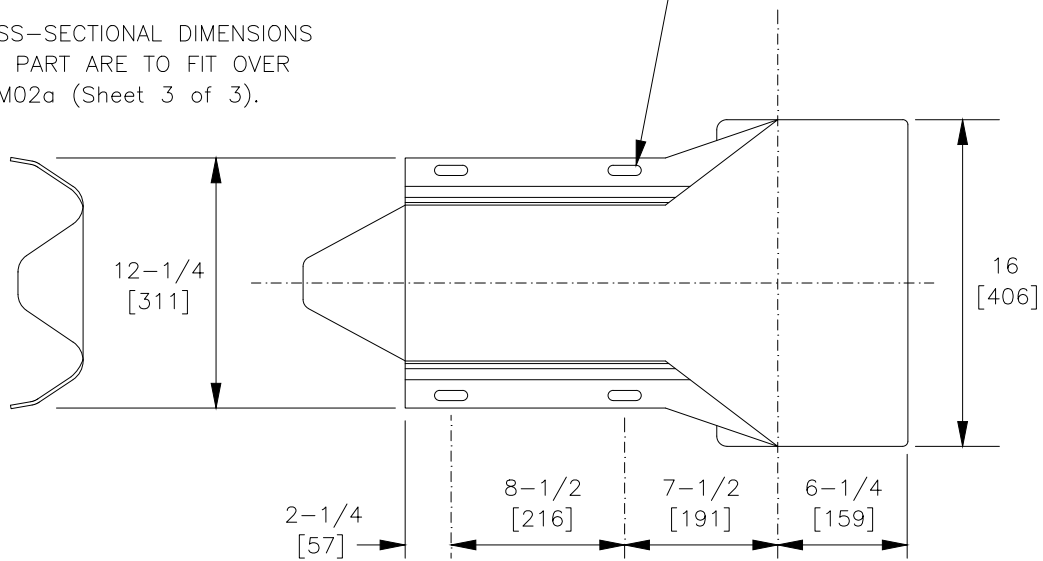

DESIGNATOR	BASE METAL THICKNESS	DIAMETER (D)
RWE05a	12 Gage [2.67]	12-1/2 [318]
RWE05b	10 Gage [3.43]	12-1/2 [318]
RWE06a	12 Gage [2.67]	24 [610]
RWE06b	10 Gage [3.43]	24 [610]
RWE07a	12 Gage [2.67]	30 [762]
RWE07b	10 Gage [3.43]	30 [762]

W-BEAM END SECTION (BUFFER)



RWE05a-07b

SHEET NO.

DATE

1 of 2

5/30/2024

SPECIFICATIONS

Buffered W-Beam End Sections shall conform to the current requirements of AASHTO M180. RWE05a-07a shall conform to AASHTO M180 Class A, and RWE05b-07b shall conform to Class B.

Dimensional tolerances not shown or implied are intended to be those consistent with the proper functioning of the part, including its appearance and accepted manufacturing practices.

INTENDED USE

RWE05a-07b Buffered End Sections are used in various W-Beam guardrail systems.

CONTACT INFORMATION

Task Force 13 (TF13)
a Non-Profit Association
<https://TF13.org>

W-BEAM END SECTION (BUFFER)

RWE05a-07b



SHEET NO.

DATE

2 of 2

5/30/2024