

4-SPACE W-BEAM ANCHOR GUARDRAIL

RWM14Q

SHEET NO.

1 of 2

DATE

6/4/2024

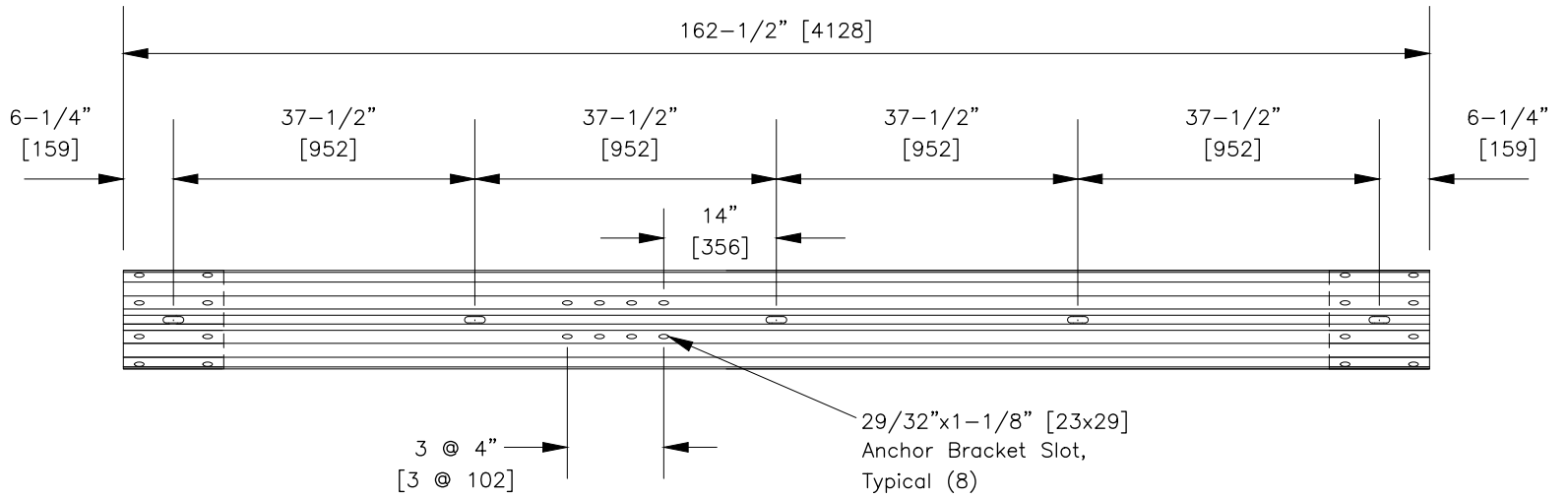

FRONT ELEVATION VIEW

Cross-Section Dimensions for this part are the same as Part RWM02a-b, Sheet 3 of 3.

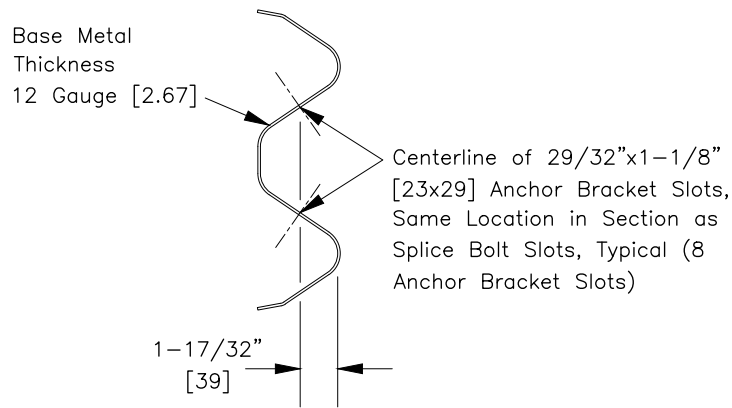

SECTION VIEW

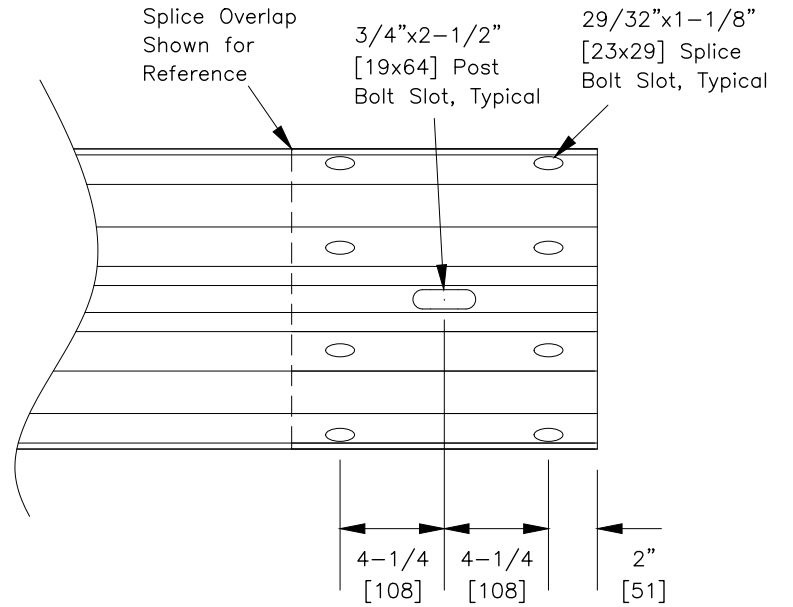

END DETAIL, TYPICAL

SPECIFICATIONS

Corrugated sheet steel w-beam shall conform to the current requirements of AASHTO M180. The section shall be manufactured from sheets with a nominal width of 19" [483]. RWM04a shall conform to AASHTO M180 Class A. Inertial properties are calculated for the whole cross-section without a reduction for holes or slots.

Designator	Base Metal Thickness Gauge [mm]	Area in ² [10 ³ mm ²]	I _x in ⁴ [10 ⁶ mm ⁴]	I _y in ⁴ [10 ⁶ mm ⁴]	S _x in ³ [10 ³ mm ³]	S _y in ³ [10 ³ mm ³]
RWM14a	12 [2.67]	2.01 [1.3]	2.40 [1.0]	--	1.40 [23.0]	--

Dimensional tolerances not shown or implied are intended to be those consistent with the proper functioning of the part, including its appearance and accepted manufacturing practices.

INTENDED USE

RWM14a W-beam anchor guardrail section is used in various W-beam guardrail systems.

CONTACT INFORMATION

Task Force 13 (TF13)
a Non-Profit Association
<https://TF13.org>

4-SPACE W-BEAM ANCHOR GUARDRAIL

RWM14a

SHEET NO.

2 of 2

DATE

6/4/2023

