

BILL OF MATERIALS	
1	C-POST
2	THRIE BEAM GUARDRAIL
3	SPACER
4	THRIE BEAM WASHER
5	THRIE BEAM/SPACER BOLT
6	THRIE BEAM/SPACER WASHER & NUT
7	SPACER /C-POST BOLT & RECTANGULAR WASHER
8	C-POST SQUARED WASHER & NUT
9	ROUND HEAD BOLT, ROUND WASHER & NUT

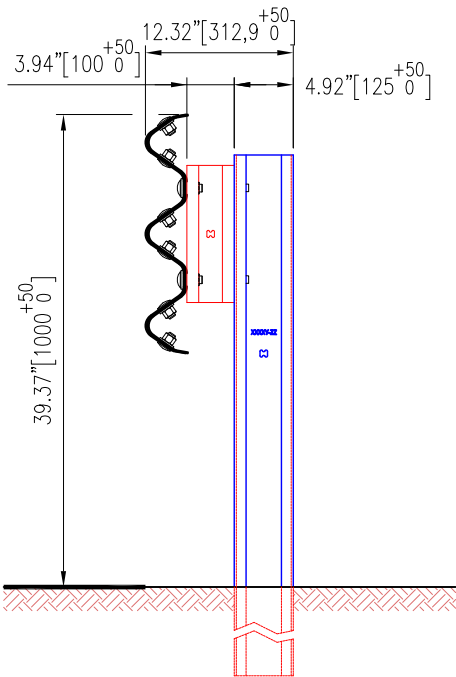

C-POST ELEVATION

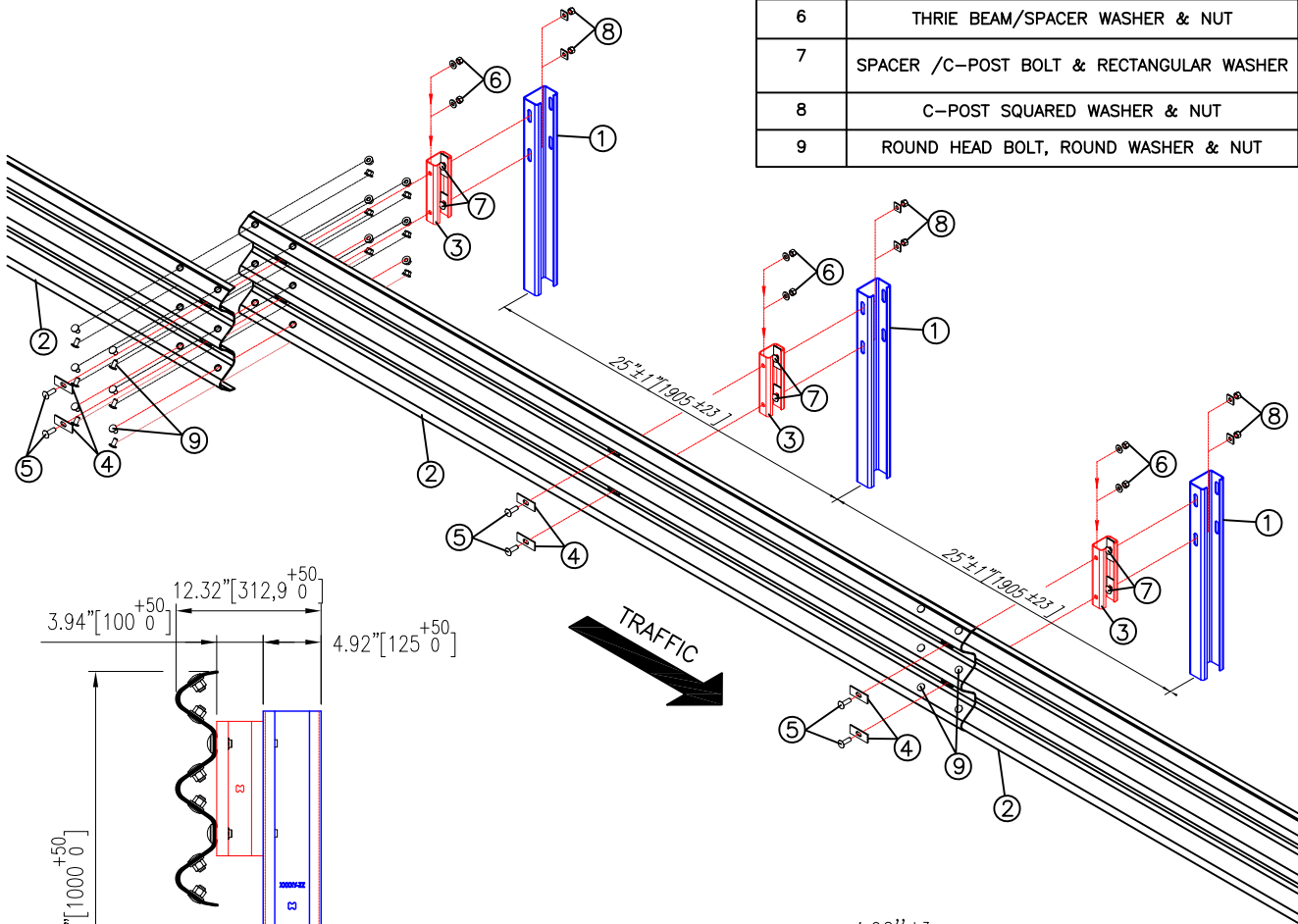
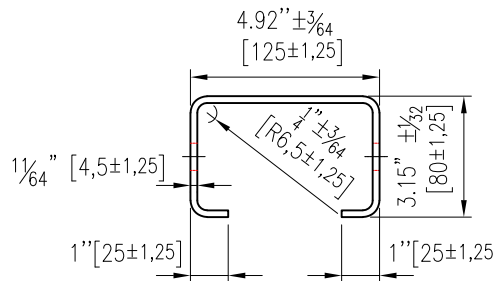

C-POST PLAN

”TRIONDA S2-TL4 MASH” HIGH CONTAINMENT GUARDRAIL



Gonvarri
Colombia

S2-TL4MASH-271023-FHWA-001

SHEET NO.

DATE:

1 of 2

27/10/23

INTENDED USE

"TRIONDA S2-TL4 MASH" is a fully compliant TL4 MASH longitudinal guardrail barrier system and it can be used in TL4 design locations where maximum dynamic deflection of 4.07ft. or less is acceptable. "TRIONDA S2-TL4 MASH" system must be anchored with a suitable terminal system. The system post spacing is 75 inches [1905 mm].

COMPONENTS (unit length 150 in [3810])

Component	Quantity
Thrie-beam rail 4130 mm	1
Post C-125x80x4.5	2
Spacer Thickness 4.5 mm	2
Round Head Bolt TBC M.16x30 Class 5.8	12
Round Head Bolt TBC M.16x50 Class 8.8	4
Bolt CRF-10.5 M.16x50 Class 5.8	4
Rectangular Flat Washer 100x40x5 ϕ 18 mm	8
Squared Flat Washer 35x35x5 ϕ 18 mm	4
Circular Washer M.16 ϕ 18 mm	16
Nut M.16 Class 5	20

CONTACT INFORMATION

Road Steel Engineering
Paseo de Belén, 11-Edificio UVainnova-Campus Miguel Delibes
47011-Valladolid, España (Spain) Tel: (+34) 983 990 468
e-mail:info@roadsteel.com-http://www.roadsteel.com

"TRIONDA S2-TL4 MASH" HIGH CONTAINMENT GUARDRAIL



Tel: (+34) 985 128200
+34) 983 990468

info@roadsteel.com
http://www.roadsteel.com



Gonvarri
Colombia

S2-TL4MASH-271023-FHWA-002

SHEET NO.

DATE:

2 of 2

27/10/23