

PO Box 602, Highland, CA 92346  
 909-793-7602 phone 909-793-1283 fax  
 www.procastproducts.com

PROJECT NAME:

**F-TYPE  
 BARRIER**

OWNER/CLIENT:

DRAWN BY:	JPL	01/10/2023
REVISED BY:	JPL	09/12/2023
CHECKED BY:	EM	09/12/2023
SUBMITTED:		
APPROVED:		

REVISION:

PROJECT NO.

SHEET TITLE:

**20' & 10' TEMP.  
 BARRIER DETAIL**

SHEET NO.

**TB2**

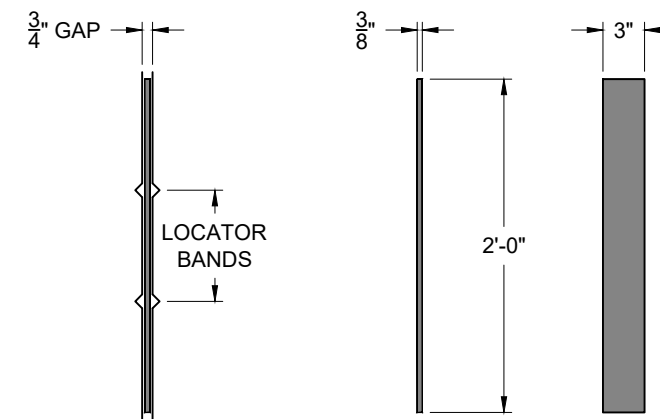
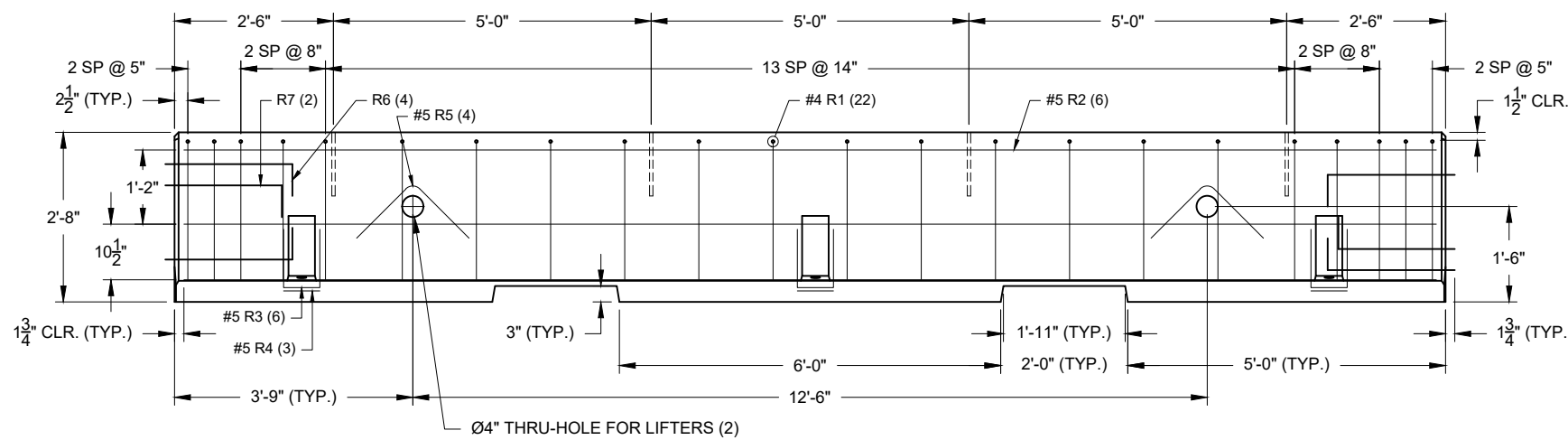
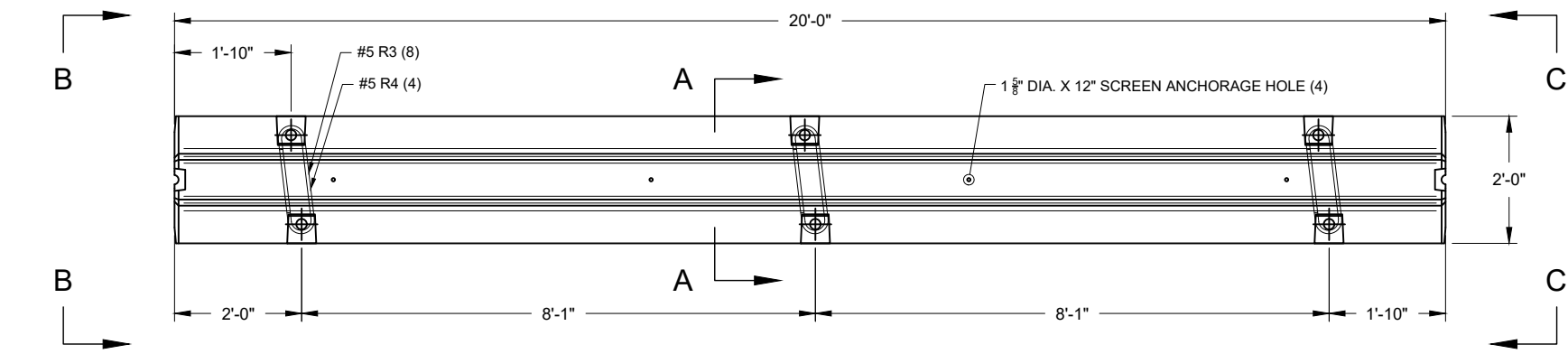

SPACER DETAIL

\*SEE NOTE 5

NOTES:

1. MINIMUM CONCRETE STRENGTH 4000-PSI (27.6MPa) IN 28 DAYS
2. REINFORCING DEFORMED BARS COMPLYING WITH ASTM A706/A706M GRADE 60. WELDED WIRE REINFORCEMENT MAY BE USED ON AN EQUIVALENT AREA BASIS AND SHALL COMPLY WITH ASTM A1064/A1064M
3. STEEL BAR LOOPS COMPLYING WITH ASTM A36/A36M
4. CONNECTING PINS ARE ROUND BARS COMPLYING WITH ASTM A36/A36M A MINIMUM LENGTH OF 26" INCHES AND HAVE A HEAD OF 3" INCH DIAMETER
5. SPACER OF UNIFORM DENSITY PLASTIC, METAL, OR OTHER SUITABLE MATERIAL MAY BE USED PROVIDED THE MATERIAL HAS A MINIMUM COMPRESSIVE STRENGTH OF 6000-PSI (41.4MPa)
6. DESIGN MEETS THE REQUIREMENT OF MASH TL-3
7. IDENTIFICATION WILL INCLUDE MANUFACTURER'S NAME, MONTH AND YEAR. IF REQUIRED LOT NUMBERS MAY BE INCLUDED

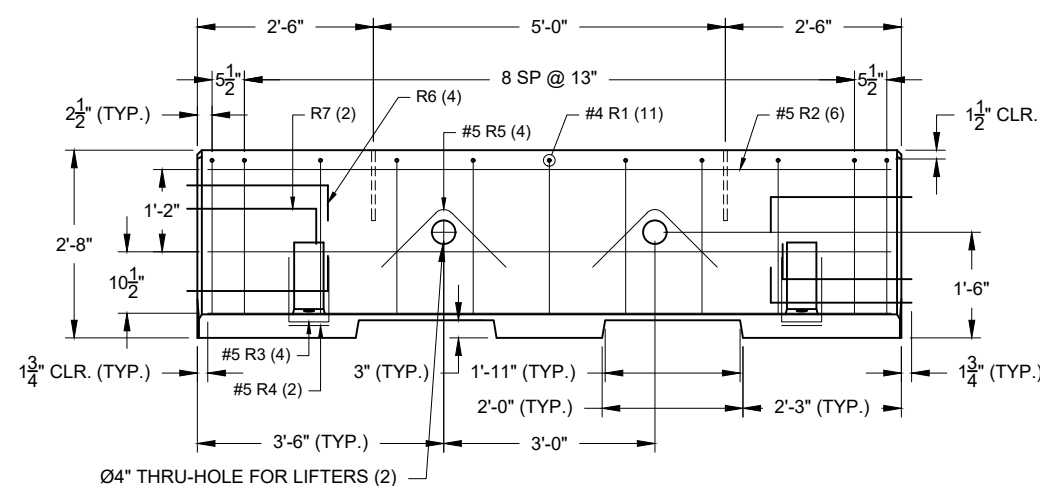
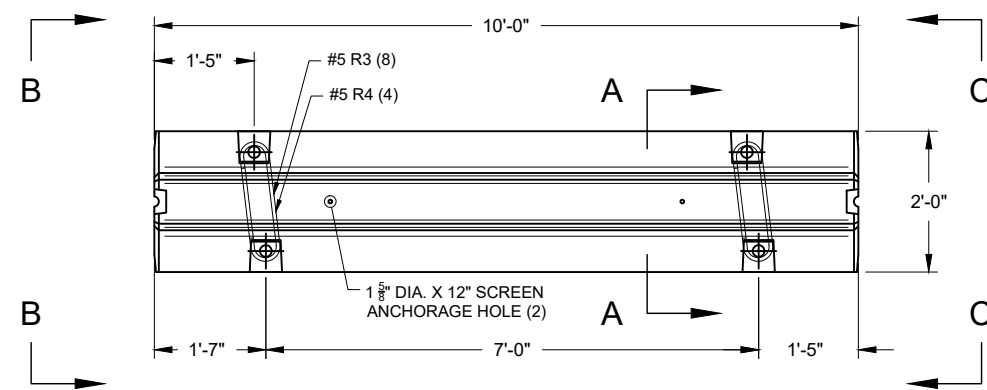

**20' & 10' TEMPORARY BARRIER DETAIL**

THIS DOCUMENT IS THE PROPERTY OF PROCAST PRODUCTS INC. IT IS CONFIDENTIAL AND SHALL NOT BE USED IN ANY WAY INJURIOUS TO THE INTERESTS OF, OR WITHOUT THE WRITTEN PERMISSION OF PROCAST PRODUCTS INC. PATENTED, PATENT PENDING AND OR COPYRIGHT. ALL RIGHTS RESERVED.

Submitted for Approval: 09/12/2023

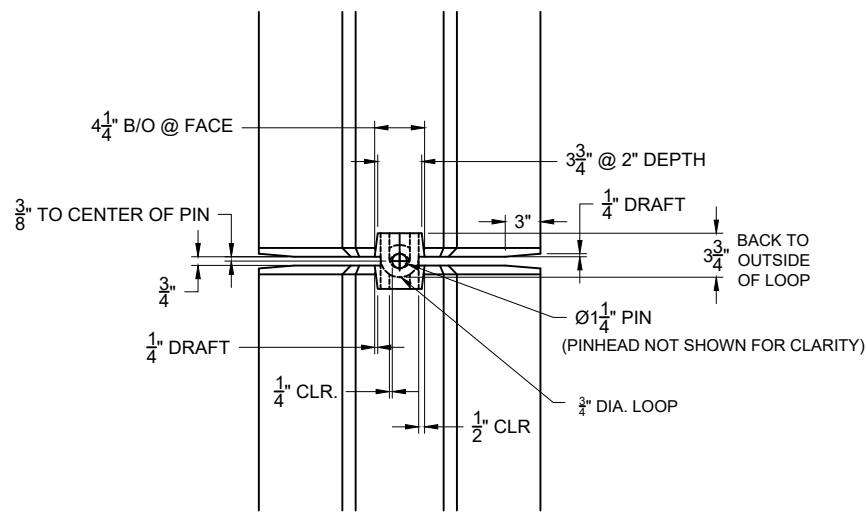

PLAN VIEW

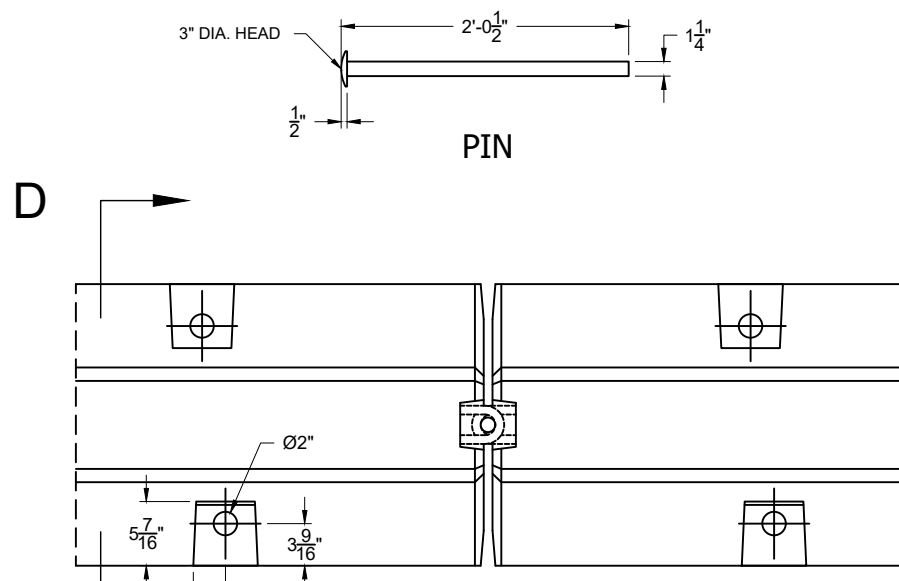

CONNECTION PLAN VIEW

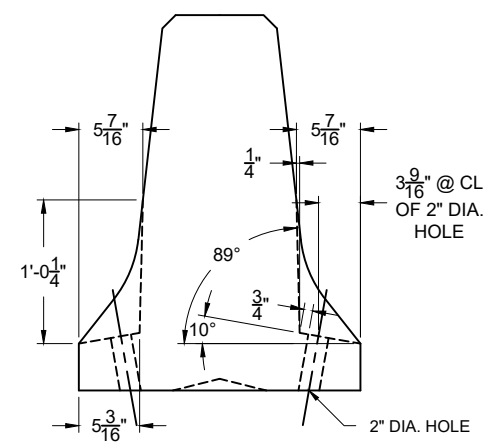

SECTION D-D

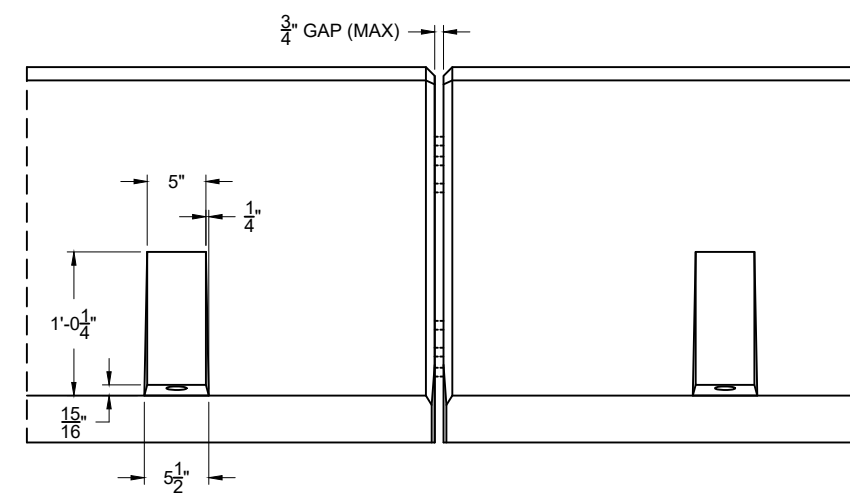

CONNECTION ELEVATION

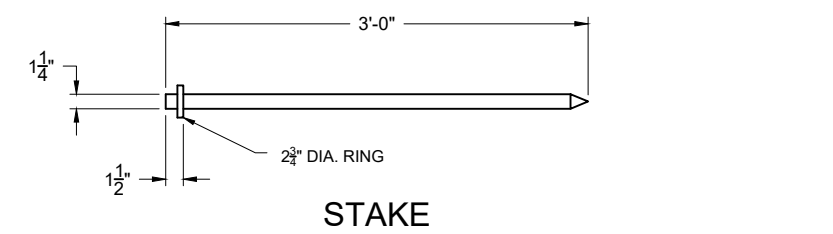

STAKE

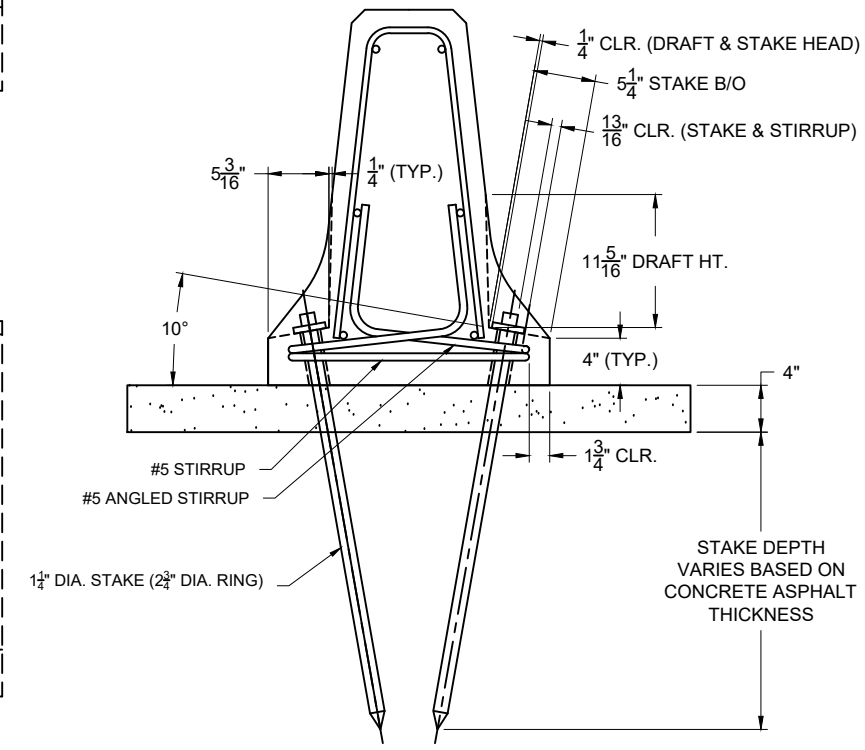

# TEMPORARY BARRIER - STAKE HOLE DETAIL

THIS DOCUMENT IS THE PROPERTY OF PROCAST PRODUCTS INC. IT IS CONFIDENTIAL AND SHALL NOT BE USED IN ANY WAY INJURIOUS TO THE INTERESTS OF, OR WITHOUT THE WRITTEN PERMISSION OF PROCAST PRODUCTS INC. PATENTED, PATENT PENDING AND OR COPYRIGHT. ALL RIGHTS RESERVED.

Submitted for Approval: 09/12/2023

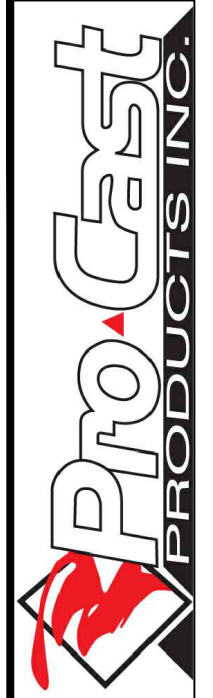

PO Box 602, Highland, CA 92346  
909-793-7602 phone 909-793-1283 fax  
www.procastproducts.com

PROJECT NAME:

**F-TYPE BARRIER**

OWNER/CLIENT:

DRAWN BY:	JPL	01/10/2023
REVISED BY:	JPL	09/12/2023
CHECKED BY:	EM	09/12/2023
SUBMITTED:		
APPROVED:		

REVISION:

PROJECT NO.

SHEET TITLE:

**STAKE HOLE DETAIL**

SHEET NO.

**TB3**